

System 450 Series Modular Control Systems with Standard Control Modules Technical Bulletin



C450CBN, C450CCN, C450CPN, C450CQN, C450CPW, C450SPN, C450SQN, C450SBN, C450SCN, C450YNN

Johnson Controls

LIT-12011459

www.penncontrols.com

2021-07-21



Contents

Introduction.....	5
System 450 Overview.....	5
System 450 Control Systems with standard control modules.....	6
Control module and UI.....	7
Expansion modules, module assemblies, and outputs.....	9
Module assemblies, output types, and output numbers.....	9
Hybrid analog output.....	10
System 450 compatible sensors and transducers.....	11
System 450 sensors and transducers for standard control modules.....	12
Binary input sensor.....	13
System 450 functional sensors.....	13
Relay outputs.....	14
Analog outputs.....	18
High input signal selection.....	24
Differential control.....	24
Sensor Failure mode.....	26
System 450 control system examples.....	26
Control system example.....	26
Hybrid analog and high input signal selection control system example.....	31
Designing and building System 450 control systems.....	33
Selecting, installing, and setting up sensors.....	33
Assembling System 450 modules.....	34
Locating System 450 modules.....	34
Mounting.....	34
Mounting modules on DIN rail.....	34
Direct-mounting modules.....	35
Wiring System 450 components.....	35
Wiring System 450 sensors and transducers.....	39
Setting up a System 450 control system.....	39
Determining output numbers and output types.....	39
System 450 UI navigation guidelines.....	40
Accessing and navigating the UI.....	40
Viewing the System Status screens.....	41
Accessing the System Setup screens.....	41
Setting up the sensors and transducers.....	43
Setting up control system outputs.....	45
Relay output setup.....	45
Setting up a relay output.....	46
Analog output setup.....	48
Setting up an analog output.....	49
Pulse region hybrid analog output setup.....	51

Setting up a pulse region hybrid analog output.....	51
Setting up outputs that reference a P 110 sensor.....	52
Determining the integration constant for an analog output.....	53
Testing the slowest to fastest time integral to determine I-C setting.....	53
Using the response time to a step change to determine the I-C Setting.....	54
Troubleshooting System 450 control systems.....	56
Specified voltage ranges for sensors.....	56
Repair and ordering information.....	57
Related documentation.....	61
System 450 Series Modular Control Systems with Standard Control modules technical specifications	62
North American emissions compliance.....	67
United States.....	67
Canada.....	67
Glossary of terms.....	68
Product warranty.....	76
Single point of contact.....	76
Contact information.....	76

Introduction

This document describes the System 450™ features and functions, and provides guidelines and instructions to design, select, install, set up, and troubleshoot the System 450 controls that use standard control modules (C450CBN-4, C450CCN-4, C450CPN-4, C450CQN-4) or the hybrid analog output module (C450CPW-400).

This document also provides information and instructions to select, install, and set up sensors, expansion modules, and the power module in your control systems with standard control modules or the hybrid analog control module.

This document also provides System 450 [Related Documentation](#) and references to System 450 [System 450 Overview](#).

For information about System 450 modules with reset control (C450RxN-x), refer to the *System 450 Series Modular Control Systems with Reset Control Modules Technical Bulletin (LIT-12011842)*.

For information about System 450 modules with network communications, refer to the *System 450 Series Modular Control Systems with Communications Control Modules Technical Bulletin (LIT-12011826)*.

- ▶ **Important:** Use this System 450 Series Modular Control Systems with Standard Control Modules only as an operating control. Where failure or malfunction of the System 450 Control System could lead to personal injury or property damage to the controlled equipment or other property, additional precautions must be designed into the control system. Incorporate and maintain other devices, such as supervisory or alarm systems or safety or limit controls, intended to warn of or protect against failure or malfunction of the System 450 Control System.
- ▶ **Important:** Utiliser ce System 450 Series Modular Control Systems with Standard Control Modules uniquement en tant que dispositif de contrôle de fonctionnement. Lorsqu'une défaillance ou un dysfonctionnement du System 450 Control System risque de provoquer des blessures ou d'endommager l'équipement contrôlé ou un autre équipement, la conception du système de contrôle doit intégrer des dispositifs de protection supplémentaires. Veiller dans ce cas à intégrer de façon permanente d'autres dispositifs, tels que des systèmes de supervision ou d'alarme, ou des dispositifs de sécurité ou de limitation, ayant une fonction d'avertissement ou de protection en cas de défaillance ou de dysfonctionnement du [nom abrégé de l'appareil].

System 450 Overview

The System 450 Series is a family of compact digital electronic control, expansion, and power modules that you can assemble and set up to provide on/off and proportional control of temperature, pressure, and humidity conditions in a wide variety of HVAC, commercial, or industrial process applications.

The System 450 Series replaces the System 350 Series and System 27 Series control systems, and provides more features and flexibility with fewer model variations. Most System 350 and System 27 modules are designed for single condition applications, such as temperature, pressure, or humidity; you cannot configure them to control multiple conditions with a single control system. Based on the control module model you have, a single System 450 control system can monitor and control both temperature and humidity, or temperature, pressure, and humidity simultaneously.

- ① **Note:** System 450 modules are not compatible with System 350 or System 27 modules. However, you can build all of the System 350 and System 27 control systems and many more with fewer System 450 modules.

The System 450 Series has several model variations. Each module is designed to be multi-purpose, adaptable, and completely field configurable for temperature, pressure, and humidity applications. Use the System 450 Series to build a wide range of inexpensive, compact, durable, and versatile

custom control systems to monitor and control multiple control loops in your controlled system. A System 450 control system can monitor temperature, pressure, and humidity simultaneously and control up to 10 analog, relay, or both outputs based on the monitored conditions.

- ① **Note:** System 450 communications control modules, System 450 standard control modules, and the System 450 control module with hybrid analog output can monitor and control temperature, pressure, and humidity applications simultaneously. System 450 reset control modules can monitor and control temperature and humidity applications simultaneously.

A System 450 standard control system includes the following features:

- A single System 450 standard control module that provides the control system UI to set up, monitor, and control your system and the sensor wiring terminals for connecting the sensors to your control system
- One to 10 outputs provided by the control module and expansion modules. Each output provides either on/off control or a proportional analog signal of 0 VDC to 10 VDC or 4 mA to 20 mA to the equipment in your controlled system
- One to three sensors or transducers that you can hard-wire directly to the control module and can provide input signals to monitor and control your system equipment
- An optional power module to provide power to the connected control module and expansion modules

See Table 12 for a list of System 450 modules that can be used in standard and hybrid analog output control systems. Refer to the *System 450 Series Modular Controls Product Bulletin (LIT-12011458)* for a complete list and description of the System 450 modules, compatible sensors and transducers, and accessories.

System 450 Control Systems with standard control modules

A System 450 Control system with a standard control module can provide the following types of control to your application:

- **On/off control:** includes multi-stage control for temperature, pressure, and humidity applications. See [Relay Outputs](#).
- **Proportional analog control:** includes multi-stage control for temperature, pressure, and humidity applications. See [Analog Outputs](#).
- **Combination of on/off relay and analog output control:** includes up to 10 outputs for each control system and any combination of relay and analog outputs.
- **Multi-stage control for relay or analog:** for temperature, pressure, and humidity applications.
- **Multi-purpose control:** includes simultaneous monitoring and control of temperature, pressure, and humidity conditions.
- **Stand-alone control:** a single standard control module that you can configure to replace a wide variety of specialized controls in the field.
- **Binary input control:** connect a set of binary contacts or dry contacts to any System 450 input and control your system's relay outputs. See [Binary Input Control for Relay Outputs](#).
- **Direct and reverse action proportional control.** See [Direct and Reverse Control Actions for Analog Outputs](#).
- **Proportional plus integral control.** See [Proportional Plus Integral Control and Integration Constants](#).

- **High input signal selection:** monitor a condition with two or three identical sensors at different locations in your controlled system and control system outputs according to the highest condition value monitored by the sensors. See [High Input Signal Selection](#).
 - **Differential control:** monitor and control a condition differential in a controlled system; for example, the water pressure drop across an in-line water filter. See [Differential Control](#).
 - **Hybrid analog output control:** C450CPW-400 enables an analog VDC output to transition to a pulse output at low signal levels to provide more efficient low-speed control of electronically commutated (EC) motors in condenser fan applications. See [Hybrid Analog Output](#).
 - **Output update rate:** select the rate at which an analog output updates the output signal to the controlled equipment. See [Analog Output Update Rate](#).
 - **Output signal deadband :** create a deadband for the analog output signal within which the output signal strength remains constant. See [Analog Output Deadband](#).
 - **Four time control parameters :** set up the relay outputs with On or Off time delays and minimum On or Off times. See [Relay On and Off Duration Control](#).
 - **On/off delay:** configure an on delay for the time between a setpoint trip and the energizing of a relay, and an off delay for the time between a setpoint trip and the de-energizing of a relay.
- ① **Note:** The C450CPW-400 model only provides a hybrid analog output for direct control of EC motors. See [Hybrid Analog Output](#).

Control module and UI

Each System 450 standard control system requires a single control module. System 450 Control modules have an LCD that you can use to set up and monitor your control system, along with a four-button touchpad to navigate the control system status and setup screens, and set up the system parameters. Figure 1 shows a control module and Table 1 describes the features of the System 450 control system UI for control modules.

Figure 1: System 450 control module output analog LEDs, LCD, four-button touchpad UI

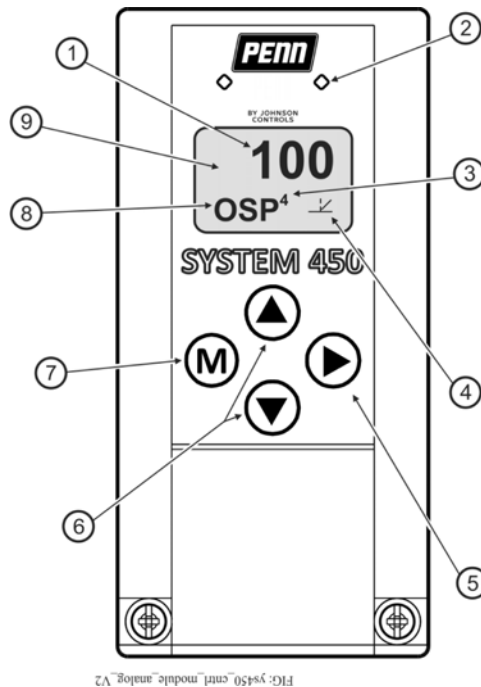

Table 1: System 450 control module output analog LEDs, LCD, four-button touchpad UI

Callout	Feature	Description
1	Status or setup value	Displays the current input status, output status, or setup parameter value for the displayed input for the Main screens. Press Up or Down to select a different parameter value when the value flashes. Here, 100 = 100%.
2	LED	Green LEDs on the control module and expansion modules indicate if the associated relay or analog output is on or off. If the analog output is partially on between 0 V–10 V, the LED blinks. The higher the output signal strength, the longer the LED is on.
3	Output number	Displays a numerical value that identifies the output associated with the status or setup value shown on the screen. Output numbers are automatically determined by the outputs' physical positions of left to right in the module assembly. Here, 4 = Output 4.
4	Control Ramp icon	Displays whether an analog output is set as direct-acting or reverse-acting, and whether the output signal strength is at minimum or maximum when the sensed property is at setpoint. The control ramp icon displayed is determined by the output's SP, EP, OSP, and OEP setup values.
5	Next button	In the Main screens, press Next to scroll through the system status screens. In a setup screen, press Next to save the flashing setup value and go to the next setup screen.
6	Up and Down buttons	Press Up or Down to select a different value for any flashing value in the setup value field. In the Main sensor status screens, press and hold both Up and Down for 5 seconds to access the setup Start screens.
7	Menu button	Press M to move through the sensor and output setup start screens. When you move through the status or setup screens, press M to return to the status start screen or setup start screen.
8	Status or setup identifier	Displays the unit of measurement, output, sensor number, or setup parameter for the displayed status or setup value. Here, the setup identifier OSP represents % output signal strength at setpoint.
9	LCD	Backlit LCD screen. The LCD brightness is adjustable. During normal operation, the LCD displays the main screens.

Standard System 450 control modules are available with one or two relay outputs or with one or two analog outputs and the standard System 450 firmware. See Table 12 for model descriptions and [System 450 Control Systems with Standard Control Modules](#) for more information.

The System 450 control module with hybrid analog output has a single analog output that can be configured as a hybrid analog output to optimize and extend the controlled speed range of variable speed EC motors. See [Hybrid Analog Output](#) for more information.

All System 450 control modules can control both relay outputs and analog outputs, regardless of the type of outputs that the control module has on-board. You set up all of the sensors and all of the relay and analog outputs, including the expansion module outputs, in the control module UI. You can also configure a standard control module as a simple stand-alone control system when your application requires only one or two relay outputs, or one or two analog outputs.

During normal operation, the LCD displays the Main System 450 sensor status screens, which automatically scroll through and display the status of the hard-wire and functional sensors in your control system. You can also view the status of all the outputs in your control system and access the System Setup screens from the Main screens in the System 450 UI. See [Setting up a System 450 Control System](#).

The System 450 System Status screens display the status of each output in the control system in addition to the sensor status screens. A relay output status displays as On or OFF. An analog output status displays as a percentage of the total output signal strength, 0% to 100%. The analog output status screens also display an icon that indicates the control action of the analog output. See [Direct and Reverse Control Actions for Analog Outputs](#).

Figure 3 illustrates the System 450 UI navigation paths, parameter designations, and values for the control system example, shown in Figure 2, using a System 450 standard control module.

Figure 3 shows the Main screens, the Sensor Status screens, the System Status screens, the System Setup screens, and the Output Setup screens for examples of the System 450 standard control application.

Expansion modules, module assemblies, and outputs

System 450 expansion modules provide additional outputs to expand your control systems and meet your specific application requirements.

A System 450 control system provides up to 10 outputs, and can consist of any combination of relay and analog outputs. Expansion modules are available with one or two relay outputs, or with one or two analog outputs. See Table 12 for information about the System 450 modules that you can use in a control system.

Figure 2: System 450 module assembly example showing standard control module and expansion module positions, output positions, and output numbers

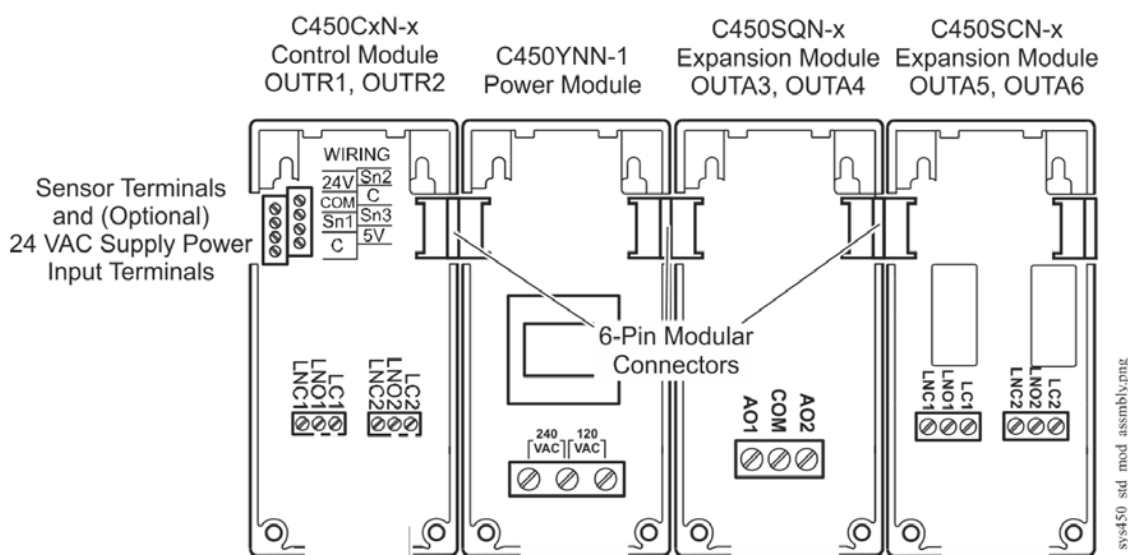

Module assemblies, output types, and output numbers

You can plug System 450 modules together using the 6-pin connectors located on the sides of the modules' housings and mount these module assemblies on a recommended standard 35 mm DIN rail or directly to a hard, even surface. See [Mounting](#).

Figure 2 shows a System 450 module assembly example, the module positions, the output types, and the automatically assigned output numbers that the System Setup screens in the control module UI use.

The control module is always mounted on the left side of the module assembly. If a System 450 power module is used, the power module is always plugged into the right side of the control module. If expansion modules are used, you can plug them into the assembly in any order on the right side of the power module, or on the right side the control module, if a power module is not used in the assembly. See [Assembling System 450 Modules](#).

Each time a System 450 module assembly is powered on, the control module polls all of the modules to identify if the output type is relay or analog, and assigns an output number from 1 to 9 and 0 = 10 to each output, starting with the first output of the control module, and then polling each expansion module connected to the right. Output numbers display on the control module LCD to identify the output that you view as you navigate the system status and setup screens in the System 450 UI (Figure 3).

Figure 3: System 450 control module UI menu flow chart example showing navigation paths and example settings in the Main, System Status, Sensor Setup, and Output Setup screens

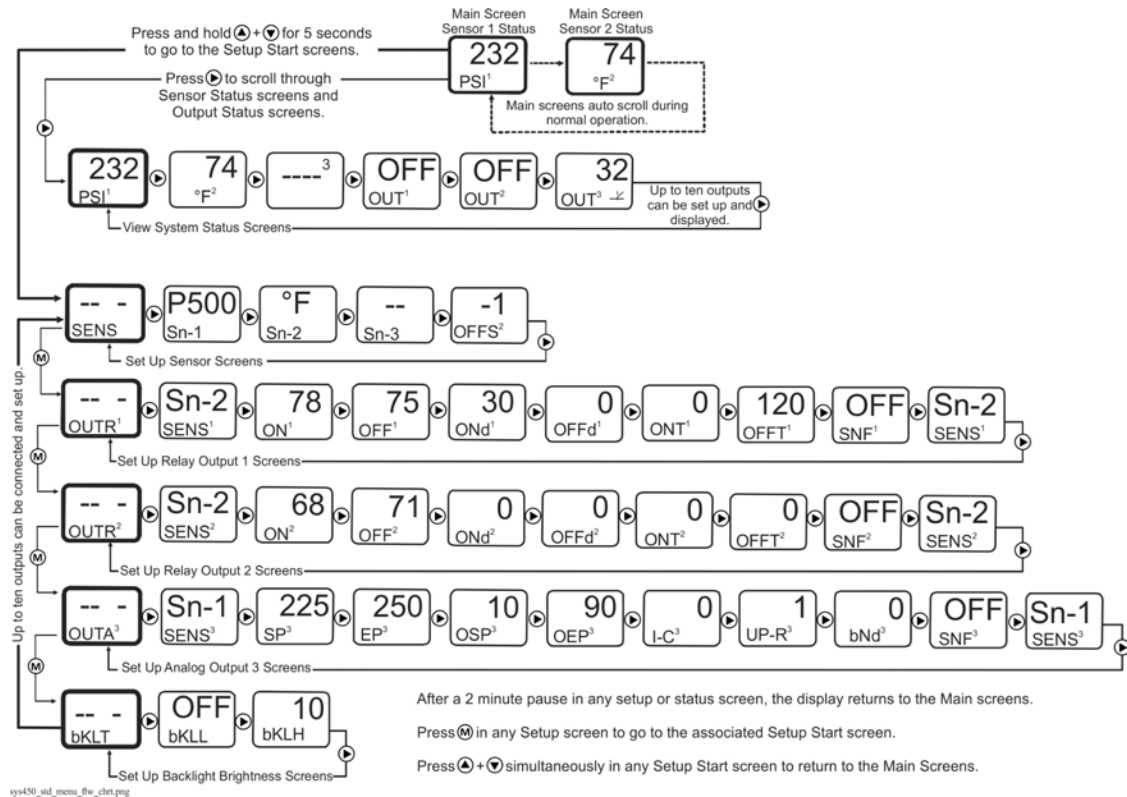

Hybrid analog output

You can use the C450CPW-400 control module with variable speed EC fan motors on a wide variety of refrigeration and HVAC condensing units.

The C450CPW-400 module has a single onboard analog output that you can configure as a hybrid analog output to optimize and extend the controlled speed range of variable speed EC motors. You can also set up the onboard analog output for High Input Signal Selection to enable precise and efficient EC motor speed control on multi-circuit condensing units.

Hybrid analog output control enables the C450CPW-400 control module's hybrid analog output to transition between a pulse output and a standard VDC output, depending on the sensor value relative to the proportional band. At low output levels, the pulse output signal provides an average motor speed that is less than the EC motor's fixed minimum speed (Figure 4).

Figure 4: Pulse signal with pulse level = 25% and logical output = 12.5%

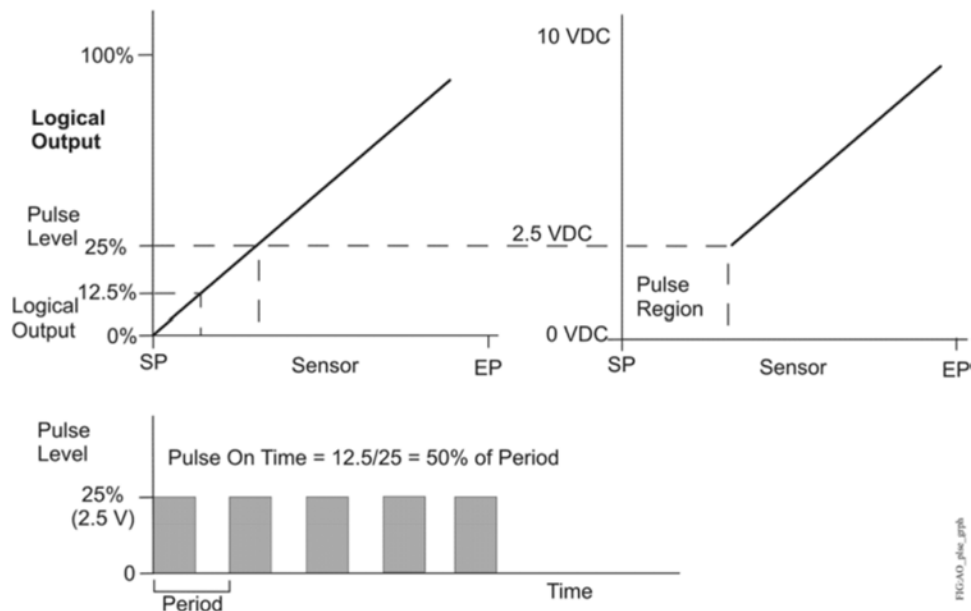

- ① **Note:** You can configure Analog Output 1 (OUTA1) only on the C450CPW-400 control module as a hybrid analog output and use the High Input Signal Selection feature. These features are not available for any of the other outputs in control systems that use a C450CPW-400 control module.

System 450 compatible sensors and transducers

System 450 standard control modules can operate with a variety of compatible sensors and transducers. The System 450 compatible sensors and transducers cover a wide range of temperature, pressure, and humidity conditions.

- ① **Note:** System 450 compatible sensors consist of temperature sensors, humidity sensors, and pressure transducers. The term sensor refers to all System 450 compatible input devices including transducers, unless noted otherwise.

System 450 compatible sensors also come in a variety of styles and configurations; you can select the sensor or transducer that best fits your control system requirements. See Table 14 through Table 23 in [Repair and ordering information](#) for more information about System 450 compatible sensors for communications control modules.

You can connect up to three sensors to a System 450 control module at the low-voltage terminal block. See [Wiring System 450 Components](#) for more information on System 450 sensor wiring terminals on control modules. Refer to the System 450 module installation instructions and the sensor installation instructions referenced in [System 450 Overview](#) for information about how to install, wire, operate, troubleshoot, and replace System 450 compatible sensors.

For each sensor in your control system, select the sensor's corresponding Sensor Type when you set up the sensors in the System 450 UI. A sensor's corresponding Sensor Type determines the controlled condition, unit of measurement, minimum differential, setup values, and ranges for each output that is set up to reference the sensor.

See Table 2 for information about Sensor Types, the corresponding output setup values and ranges, sensor models, and transducer models used in standard System 450 control systems.

The System 450 control automatically designates the sensor connected to the Sn1 terminal and a common (C) terminal as the Sn-1 sensor in the UI. The sensor connected to the Sn2 and a C

terminal is designated Sn-2, and the sensor connected to Sn3 and a C terminal is designated Sn-3. You set up each sensor in the corresponding sensor setup screens in the UI.

- ① **Note:** For a System 450 control system to operate properly, you must wire the correct sensor or transducer model to the correct sensor input terminals on the control module and select the correct Sensor Type in the corresponding **Select Sensor Type** screen in the System 450 UI.

See [Setting up a System 450 Control System](#) and [Setting Up the Sensors and Transducers](#) for more information and procedures about how to set up sensors and Sensor Types in the System 450 UI.

System 450 sensors and transducers for standard control modules

The following table shows the Sensor Types, output setup values, value ranges, and product types for the temperature sensors, humidity sensors, and pressure transducers that are compatible with System 450 standard control modules.

Table 2: System 450 sensor types, setup values, and senso and transducer product codes

Sensor type	Unit of measurement value; condition or units	Effective sensing range	Range of usable values	Resolution increment value	Minimum proportional or control band	Sensor product type number
°F	°F; temperature or degrees	-46 to 255	-40 to 250	1	1	A99x-xxx
°C	°C; temperature or degrees	-43 to 124	-40 to 121	0.5	0.5	A99x-xxx
rH	%; humidity or %RH	1 to 100	10 to 95	1	2	HE-68Nx-0N00WS HE-69Sx0NP
P 0.25	INWC; pressure or in. W.C.	-0.250 to 0.250	-0.225 to 0.250	0.005	0.010	DPT2650-R25B-AB
P 0.5		0 to 0.5	0.025 to 0.5	0.005	0.010	DPT2650-0R5D-AB
P 2.5		0 to 2.5	0.1 to 2.5	0.02	0.1	DPT2650-2R5D-AB
P 5		0 to 5.0	0.25 to 5.0	0.05	0.25	DPT2650-005D-AB
P 8	bAR; pressure or bar	-1 to 8	-1 to 8	0.05	0.1	P599RCHS401C P599RCPS401C
P 10	INWC; pressure or in. W.C.	0 to 10	0.5 to 10	0.05	0.2	DPT2650-10D-AB
P 15	bAR; pressure or bar	-1 to 15	-1 to 15	0.1	0.2	P599RCPS402C
P 30		0 to 30	0 to 30	0.1	0.4	P599RCHS404C P599RCPS404C
P 50		0 to 50	0 to 50	0.2	0.4	P599RCPS405C
P 100	PSI; pressure or psi	0 to 100	0 to 100	0.5	1	P599RAPS101C P599RAPS101K P599RCPS101C P599RCPS101K
P 110	Hg/PSI; pressure or Hg-psi	-10 to 100	-10 to 100	0.5	1	P599RAPS100C P599RAPS100K P599RCPS100C P599RCPS100K
P 200	PSI; pressure or psi	0 to 200	0 to 200	1	1	P599RAPS102C P599RAPS102K P599RCPS102C P599RCPS102K
P 500		0 to 500	90 to 500	1	5	P599RAPS105C P599RAPS105K P599RCPS105C P599RCPS105K
P 750		0 to 750	150 to 750	2	6	P599RAPS107C P599RAPS107K P599RCPS107C P599RCPS107K

Table 2: System 450 sensor types, setup values, and senso and transducer product codes

Sensor type	Unit of measurement value; condition or units	Effective sensing range	Range of usable values	Resolution increment value	Minimum proportional or control band	Sensor product type number
HI°F	°F; temperature or degrees	-50 to 360	-40 to 350	1	1	TE-631x TE-6000-1 TE-6000-1x TE-6000-6 TE-68NT-0N00S
HI°C	°C; temperature or degrees	-45.5 to 182	-40 to 176	0.5	0.5	TE-631x-x TE-6000-1 TE-6000-1x TE-6000-6 TE-68NT-0N00S
bin	Open or Closed	N/A	N/A	N/A	N/A	N/A

① Note:

- The System 450 Differential Sensor Sn-d is set up and calculated with the two identical sensors Sn-1 and Sn-2. This set up means that the range of usable values is twice as large as a single sensor. See [Differential control](#) for the range of usable values when an output references Sn-d.
- See [Repair and ordering information](#) for more information about the compatible sensors for the System 450.
- See [Setting up control system outputs](#) for information about how to set up System 450 outputs that reference the P110 Sensor Type.
- Many of the temperature sensors that you can set up as HI°F or HI°C Sensor Types are not designed for use across the entire range of usable values for HI°C HI°F and Sensor Types. See [Repair and ordering information](#) or [System 450 Series Modular Control Systems with Standard Control modules technical specifications](#) to determine the sensor hardware configuration and temperature. The TE-6000-6 Nickel Sensor is the only sensor that you can use over the entire temperature range.
- If you select the bin Sensor Type for a Sn-1, Sn-2, or Sn-3 sensor, the input sets up to control the relay outputs only, based on the state of the binary input contacts, open or closed, connected to the Sn1, Sn2, or Sn3 sensor input . See [Binary input control for relay outputs](#).

Binary input sensor

You can connect a binary input with dry contacts to any of the three System 450 control module Sn1, Sn2, or Sn3 inputs and control output relays in your control system based on the binary input state of open or closed.

A Sn1, Sn2, or Sn3 input set up as a binary input can be referenced by relay outputs only. Sensors set up as binary inputs are not available for selection when you set up an analog output. When you select a sensor in the UI that is set up as a binary input, the On value and the OFF value selection screens are not available in the Relay Output Setup screens. See [Binary Input Control for Relay Outputs](#).

System 450 functional sensors

System 450 control modules also enable several functional sensors based on the input from one or more of the hard-wired sensors in your control system. Selecting a functional sensor for an output

on a System 450 control system enables the differential or high signal selection control features on the output.

System 450 standard control modules provide for three functional sensors:

- When Sn-1 and Sn-2 are set up as the same Sensor Type, the High Input Signal Selection functional sensor (HI-2) and Differential Control functional sensor (Sn-d) are enabled and available in the Sensor Selection screens for each output in the control system.
- When Sn-1, Sn-2, and Sn-3 are the same Sensor Type, the High Input Signal Selection functional sensor (HI-3) is also enabled and available.

See [High Input Signal Selection](#) and [Differential Control](#) for more information about these functional sensors and system control features.

Relay outputs

Relay outputs provide low and line-voltage on/off control for devices and equipment in your controlled systems. Each relay output is a single-pole, double-throw (SPDT) set of dry contacts. See Figure 18.

Note: System 450 output relays are SPDT dry contact relays only and they do not provide any power source for your controlled equipment.

Selecting an ON value that is less than the OFF value ($ON < OFF$) turns the relay on when the sensed condition value decreases, which is the typical heating mode in temperature applications and referred to as reverse-acting on/off control.

Selecting an ON value that is greater than the OFF value ($ON > OFF$) turns the relay on when the sensed condition value increases, which is the typical cooling mode in temperature applications and referred to as direct-acting on/off control.

You can set up multiple relay outputs to create a variety of equipment staging control systems. See [Wiring System 450 Components](#) for information on wiring output relays. See [Related Documentation](#) for the relay output electrical ratings.

A green LED on the relay control and relay expansion module housings (Figure 1) indicates the relay output status.

When a relay output is On:

- the corresponding green LED on the module housing is lit
- the LC to line normally open (LNO) relay contact is closed
- the LC to line normally closed (LNC) relay contact is open
- the corresponding Output Status screen in the UI displays **On**

When a relay output is Off:

- the corresponding green LED on the module housing is not lit
- the LC to LNO relay contact is open
- the LC to LNC relay contact is closed
- the corresponding Output Status screen in the UI displays **OFF**

System 450 control and expansion modules are available with one or two relay outputs. See Table 12 and [Related Documentation](#) for more information about the System 450 series modules.

A relay output's control action is determined by the values that you select in the ON and OFF relay output setup screens:

- Relay ON values (ON) are the values at which the relay turns On.

- Relay Off values (OFF) are the values at which the relay turns Off.

Table 3 illustrates direct and reverse relay actions. When you select On/Off condition values where OFF is less than On, the output relay is a direct-acting relay. When you select condition values where On is less than Off, the output relay is a reverse-acting relay.

Table 3: System 450 output relay control actions and the relationship between ON and OFF values

Control action	Set the relay output ON/OFF value relationships for the preferred control action
<p>Relay State</p> <p style="text-align: center;">Direct-Acting Relay OFF < ON</p> <p style="text-align: center;">Sensed Condition</p>	OFF < ON
<p>Relay State</p> <p style="text-align: center;">Reverse-Acting Relay ON < OFF</p> <p style="text-align: center;">Sensed Condition</p>	ON < OFF

In temperature applications, direct-acting relays are often used to control cooling equipment, while reverse-acting relays are often used to control heating equipment.

In pressure applications, direct-acting relays are often used for condenser fan cycling control or pump-down control, while reverse-acting relays may be used for high pressure cut-out.

In humidity applications, direct-acting relays often control dehumidification equipment, and reverse-acting relays often control humidification equipment.

Binary input control for relay outputs

You can connect a binary input or a set of dry contacts to any of the three Sn-1, Sn-2, or Sn-3 and C control module inputs and control the output relays in your control system based on the binary input's state of open or closed.

A Sn-1, Sn-2, or Sn-3 sensor set up as a binary input can only be referenced by a relay output. Sensors set up as binary inputs are not available for selection when you set up an analog output.

When a relay output references a Sn-1, Sn-2, or Sn-3 sensor that is set up as a binary input, the ON and OFF parameter screens are not available as you set up the output. The relay output's On/Off state is controlled by the binary input's state and any of the ONT, OFFT, ONd, or OFFd timer parameters that you set up for the relay output. When the binary input is closed, the relay is On. When the binary input is open, the relay is Off. If no timer parameters are used, the relay output state directly follows the binary input state. Figure 5 and Figure 6 show examples of the binary input state and the resulting output states with and without the timer parameters applied to the output.

See [Relay On and Off Duration Control](#) for more information about binary input control, relay output behavior, and the resulting On/Off behaviors when applying the On/Off Delay Time and the Minimum On/Off Time parameters.

Relay on and off duration control

The System 450 provides four time duration control parameters that can be applied to the relay output On or Off times generated by an input sensor or a binary input. Each of the four On or Off duration control parameters can be set up for 0 to 300 seconds (5 minutes) in 1-second intervals.

The four time duration control parameters are as follows:

- **On delay:** (ONd) Delays the time that a relay output goes to the On state after reaching the On condition. See the third graph in Figure 5.
- **Off delay:** (OFFd) Delays the time that a relay output goes to the Off state after reaching the Off condition. See the bottom graph in Figure 5.
- **Minimum on time:** (ONT) Maintains the relay in the On state for the selected minimum time after reaching the On condition and overrides any sensor input that would normally switch the relay off during the Minimum On Time interval. See the third graph in Figure 6.
- **Minimum off time:** (OFFT) Maintains the relay in the Off state for the selected minimum time after reaching the Off condition and overrides any sensor input that would normally switch the relay on during the Minimum Off Time interval. See the bottom graph in Figure 6.

The top two graphs in Figure 5 and Figure 6 show an example of a binary input opening and closing (top graph in each figure) and the resulting behavior of the referenced relay output with no On/Off duration parameter applied to the relay output (second graph in each figure).

The second graph in each figure can also represent a typical example of a relay output responding to the On and Off values for any System 450 compatible sensor.

The third and the bottom graphs in Figure 5 and Figure 6 show the behavior of the output relay when the On and Off Delay parameters are applied (Figure 5) and when the Minimum On and Minimum Off parameters are applied (Figure 6) to the output.

The bottom two graphs in Figure 5 show an example of the relay output behavior when the On or Off Delay parameter is applied to the relay output (regardless of whether the relay output references a binary input or another compatible sensor).

Figure 5: Behavior of a relay output referencing a binary input or other System 450 compatible sensor and the resulting output states with the on delay and off delay parameters applied

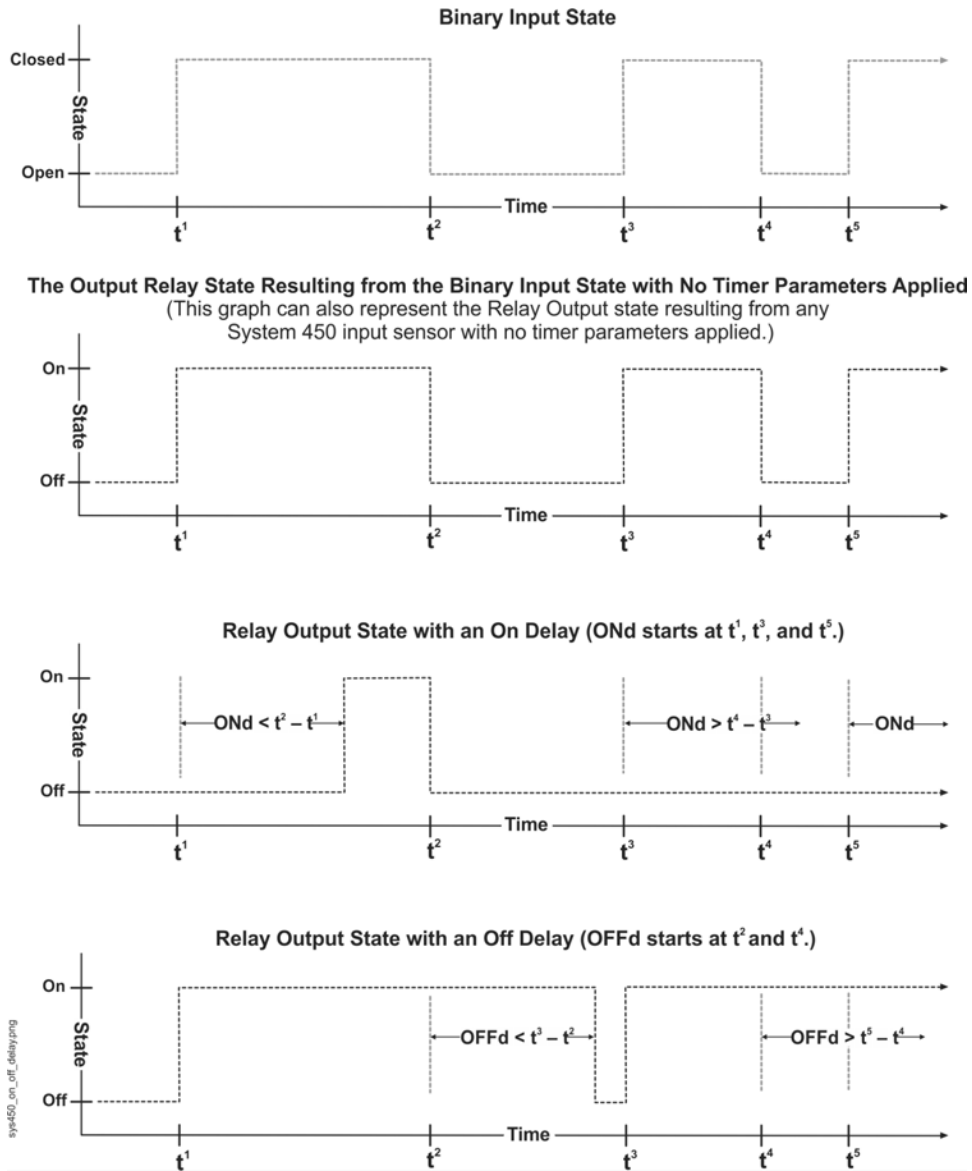

The bottom two graphs in Figure 6 show an example of the relay output behavior when the Minimum On or Off Time parameter is applied to the relay output (regardless of whether the relay output references a binary input or another compatible sensor).

Figure 6: Behavior of a relay output referencing a binary input or other System 450 sensor and the resulting output states with the minimum on and minimum off time parameters applied

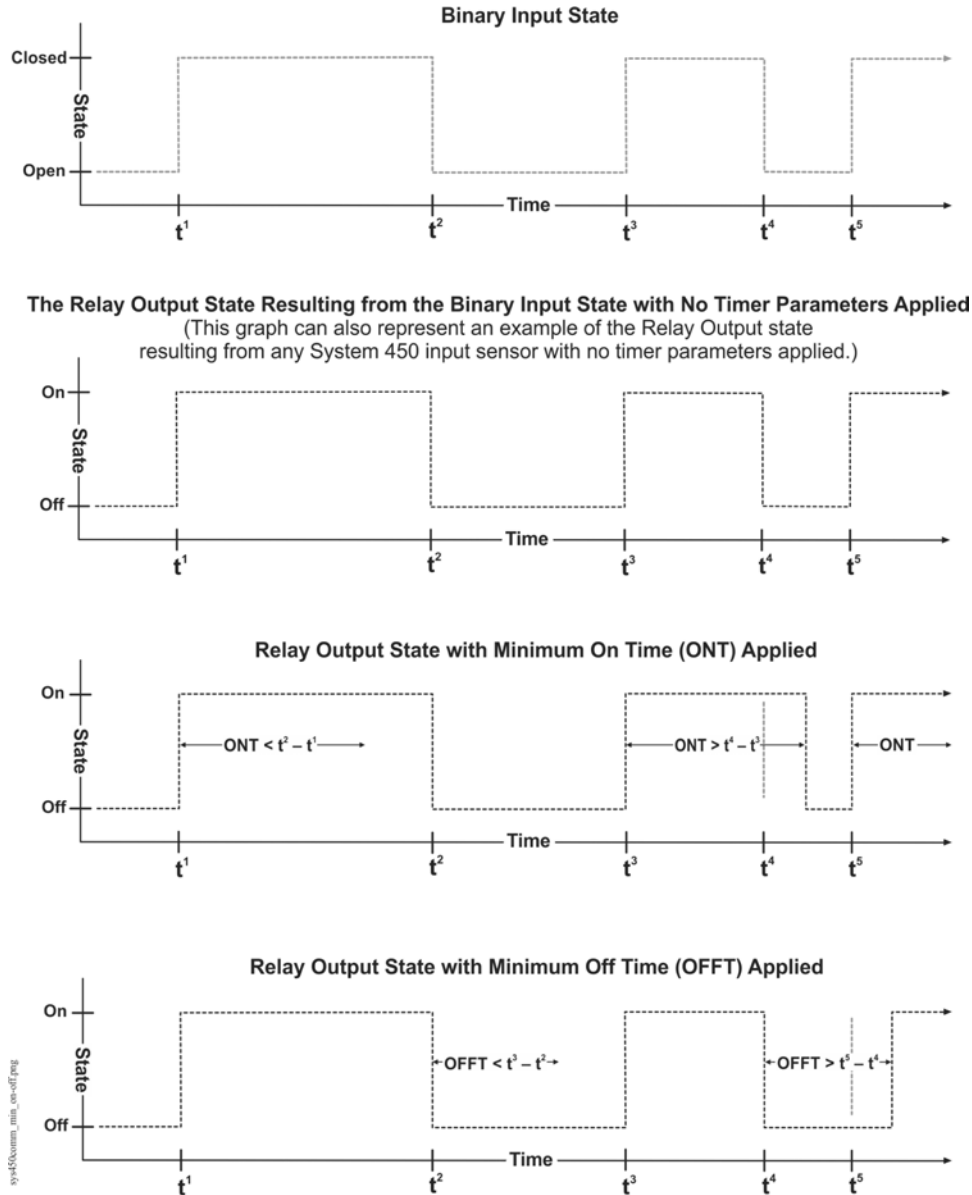

Analog outputs

Analog outputs provide proportional analog signals for devices and equipment in your controlled systems. Each analog output can generate either a 4 mA to 20 mA or 0 VDC to 10 VDC signal. The output signal type is self-selecting; after you connect the analog output to the controlled equipment, the output detects the analog input on the controlled equipment and generates the appropriate analog signal for the connected input.

You can set up an analog output to generate a direct-acting or reverse-acting proportional output signal. You can also set up the output signal strength to increase or decrease in either the direct-acting or reverse-acting mode. See [Direct and Reverse Control Actions for Analog Outputs](#) for more information.

The System 450 also provides six integration constants that allow you to set up a proportional plus integral control signal, which can provide more precise setpoint control. See [Proportional Plus Integral Control and Integration Constants](#) for information on determining the integration constant for an analog output.

For procedures on setting up analog outputs on control modules, see [Setting up an analog output](#).

The System 450 expansion modules are available with one or two analog outputs. See Table 12 and [Related Documentation](#) for more information about the System 450 Series module models that are used to build the control systems

Direct and reverse control actions for analog outputs

An analog output can be set up to provide one of four different control actions, which allow you to match the output signal to the requirements of your control system and the controlled equipment. The proportional output signal can provide direct-acting or reverse-acting control. In addition, the output signal can be set up to generate either the minimum or the maximum output signal strength at Setpoint.







A control ramp icon is displayed on the status screens for all analog outputs in your control system. See Figure 1. The displayed control ramp icon represents the control action of the analog output signal. See Table 4 for more information on analog output control actions and control ramp icons.

An analog output's control action and the corresponding control ramp are automatically determined by the values that you select in four analog output setup screens:

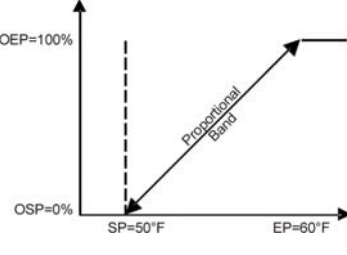
- **Setpoint** value (SP) is the target value that the control system drives toward, and along with the End Point, defines the analog output's proportional band.
 - **End Point** value (EP) is the maximum deviation from the target value (Setpoint). The control system applies maximum output at the EP to drive the process back toward the SP. The SP and EP define the analog output's proportional band.
 - **Output at Setpoint** value (OSP) is the signal strength level of the analog output when the input sensor is at Setpoint (SP). The OSP is expressed as a percentage (0 to 100%) of the full scale output.
 - **Output at Endpoint** value (OEP) is the signal strength level of the analog output when the input sensor is at the End Point (EP). The OEP is expressed as a percentage (0 to 100%) of the full scale output.
- ① **Note:** System 450 analog outputs that reference the differential control sensor (Sn-d) use a Differential Setpoint (dSP) and Differential End Point (dEP) to define the output's proportional band. See [Differential Control](#) for more information.

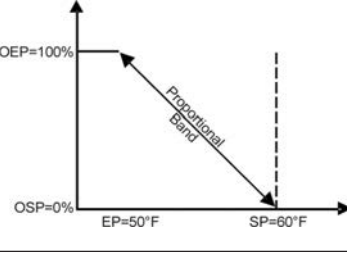
Table 4 shows the four control ramp icons and describes their corresponding control actions and the setup value relationships required to configure the four control actions. See Figure 27 and Figure 28 for examples.

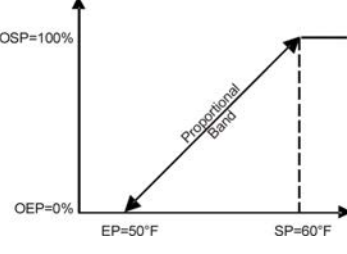
Table 4: System 450 control ramps, analog output control actions, and system setup value relationships

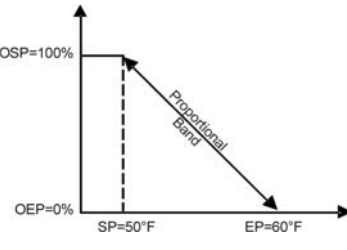
Control ramp displayed	Control action	Set the analog output value relationships for the preferred control action and corresponding control ramp
 <p>Output Minimum at SP</p>		<p>SP < EP OSP < OEP</p>
 <p>Output Minimum at SP</p>		<p>SP > EP OSP < OEP</p>
 <p>Output Maximum at SP</p>		<p>SP > EP OSP > OEP</p>
 <p>Output Maximum at SP</p>		<p>SP < EP OSP > OEP</p>

Proportional plus integral control and integration constants

In addition to standard proportional control, System 450 provides Proportional plus Integral (PI) control capability. The addition of integral control enables a properly set up analog output to drive a controlled condition closer to Setpoint (Figure 7).

Standard proportional-only controls continuously adjust the output in proportion to the difference (offset error) between the setpoint value and the sensor value. As the load on the system increases, the offset error increases. A proportional-only control responds to the increased offset error by changing the output signal, which drives the controlled equipment to compensate for the load change (Figure 7). Proportional-only control loops are relatively easy to set up and adjust.

Typically, under constant system load, proportional-only control loops do not drive a system to the selected setpoint. Instead, the controlled system is maintained at a control point within the proportional band (throttling range) between setpoint and end point. The larger the load on the system, the further the control point drifts from setpoint. Still, for many applications, proportional-only control is the best choice for analog output control.

Figure 7: Proportional-only control versus proportional plus integral control

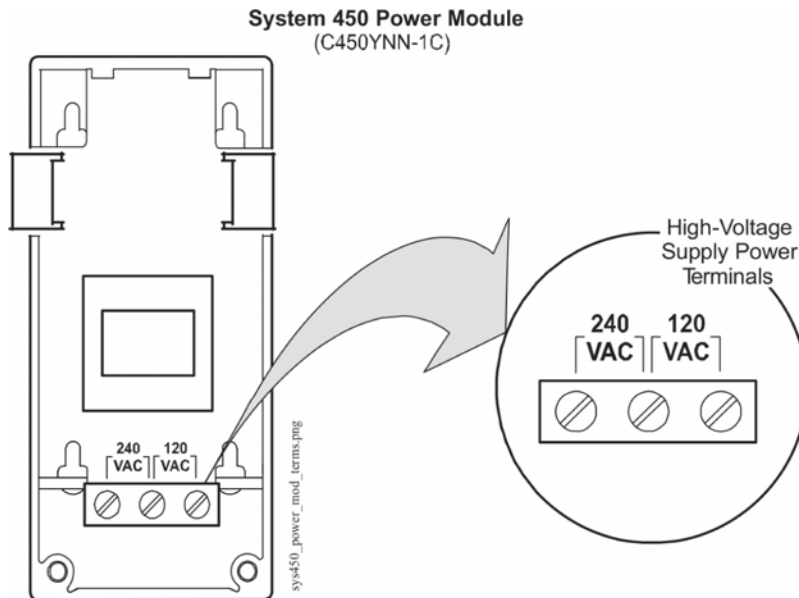

Proportional plus Integral (PI) control incorporates a time-integral control action with proportional control action and, if properly set up, a PI control loop can effectively eliminate offset error and enable a controlled system to drive to setpoint even under large constant loads (Figure 7). On a properly sized system with predictable loads, PI control can maintain the controlled system very close to setpoint.

A system's output capacity, the size of the load on the system, and the integration constant selected determine the speed (recovery rate) at which the PI control drives the system to setpoint.

The integration constant establishes the rate at which the control readjusts the analog output signal. The faster the integration constant, the faster the control readjusts the output signal and the faster the recovery rate of a properly sized and setup control loop.

- ① **Note:** PI control is not suitable for all controlled systems. Improperly applied PI control loops are unstable and can overshoot setpoint, resulting in control loop oscillation. Also, with PI control, the proportional band (throttling range) and the integration constant are interdependent and you must properly set up these values in relation to each other. You must also properly size the system equipment to handle the maximum load. Close observation over several cycles and under different load condition is required to properly set up a PI control loop. On a properly sized system, a PI control loop can drive the system condition much closer to setpoint than proportional-only control.

In addition to a proportional-only setting, System 450 provides six time-integral settings in the **Integration Constant Setup** screen for matching the analog signal's response rate to the controlled system's recovery rate. The seven integration constant settings are shown in Table 9.

See [Determining the Integration Constant for an Analog Output](#) for more information and the procedures for determining an integration constant and testing a PI control loop in your controlled system.

The Analog Output Update Rate and Output Deadband contain two parameters that can be used to minimize the frequency of changes to the output signal from the control. When controlling a device such as an actuator, these features can lengthen the actuator life by reducing the actuator position update frequency. See [Analog Output Update Limiters](#) and [Analog Output Deadband](#) for more information.

Analog output update limiters

The Output Update Rate and Output Deadband minimize the frequency of changes to the output signal from the control. When controlling a device such as an actuator, these features can lengthen actuator life by reducing the actuator position update frequency.

Analog output update rate

The output update rate feature allows you to select the rate, in seconds, during which the control does not allow an update to the analog output's signal strength. The Output Update Rate value range is 1 to 240 seconds and the default value is 1 second.

The Output Update Rate and Output Deadband are used to minimize the frequency of changes to the output signal from the control. When controlling a device such as an actuator, these features can lengthen actuator life by reducing the actuator position update frequency.

The System 450 control module calculates the input-induced output signal strength once per second. The default Output Update Rate is one second. The actual output signal strength is updated to the calculated output signal strength once every second when the control is set to the default update value. In some control applications, a 1-second update rate may be too frequent and may result in premature wear on the controlled equipment, such as actuators.

When you select an Output Update Rate value greater than 1 second, the control module delays updating the output and maintains the output signal strength for the duration of the selected update rate. At the end of the selected update rate, the control updates the output signal strength to the current calculated output signal strength and maintains the new output signal strength value for the selected output update rate value.

For example, if you select an Output Update Rate value of 5 (seconds), the control module updates the output signal strength every 5 seconds, reducing changes at the controlled equipment to 20% of the default update rate. See Figure 8.

Figure 8: Graph showing calculated output signal strength and output signal strength maintained by a 5-second update rate

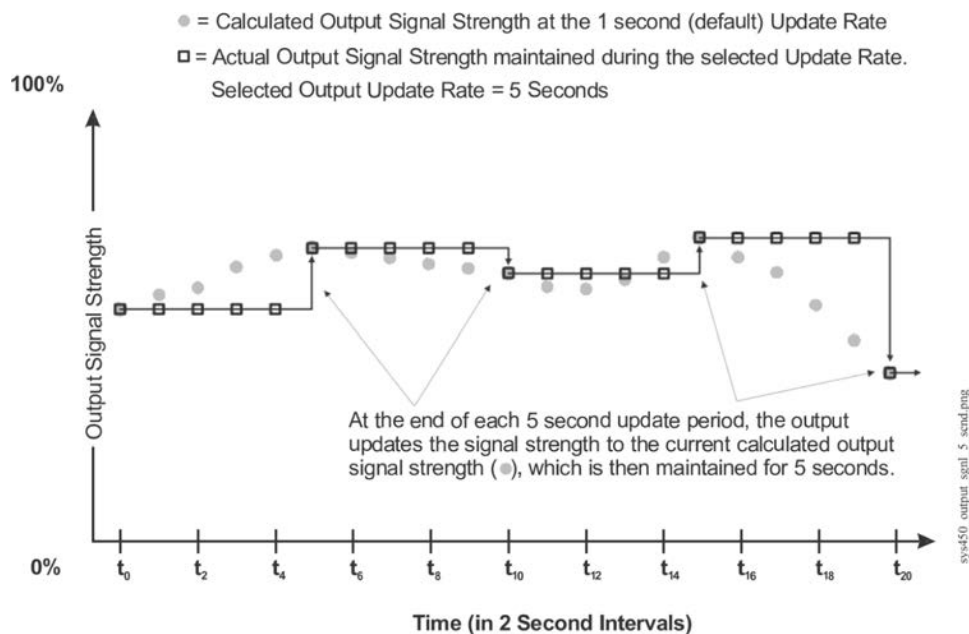

- ① **Note:** The Output Update Rate feature can be used in conjunction with the Output Deadband feature, but care must be taken when selecting these values for your control system. In process loops where the condition (temperature, pressure, or humidity) value can change quickly over a large range, the delay in updating the actual output signal strength can cause the controlled equipment to oscillate out of range and drive the process away from the desired setpoint. After selecting new Output Update Rate and Output Deadband values, observe your controlled system through several cycles to determine the affect of the new values. If the calculated output signal strength is 0 or 100%, the actual output signal strength changes immediately.

Analog output deadband

The Output Deadband feature allows you to establish a deadband value around the calculated output signal strength. The Output Deadband value is expressed as a percent of the output signal strength range. The Output Deadband value range is 0 to 50 (percent of the OSP to OEP range) and the default value is 0 (percent).

The Output Update Rate and Output Deadband are used to minimize the frequency of changes to the output signal from the control. When controlling a device such as an actuator, these features can lengthen actuator life by reducing the actuator position update frequency.

The System 450 control module responds to a changing input signal and updates the analog output's calculated output signal strength at the rate selected in the Output Update Rate screen. At each update of the calculated output signal strength, the control determines if the new calculated output signal strength is within the selected Output Deadband or not.

If the calculated output signal strength is within the selected Output Deadband, the actual output signal strength is not updated and remains unchanged.

If the calculated output signal falls outside the Output Deadband, the actual output signal strength is updated, and the selected Output Deadband is applied to the new output signal strength value. See Figure 9.

Figure 9: Graph showing calculated output signal strength and output signal strength constrained by output signal deadband

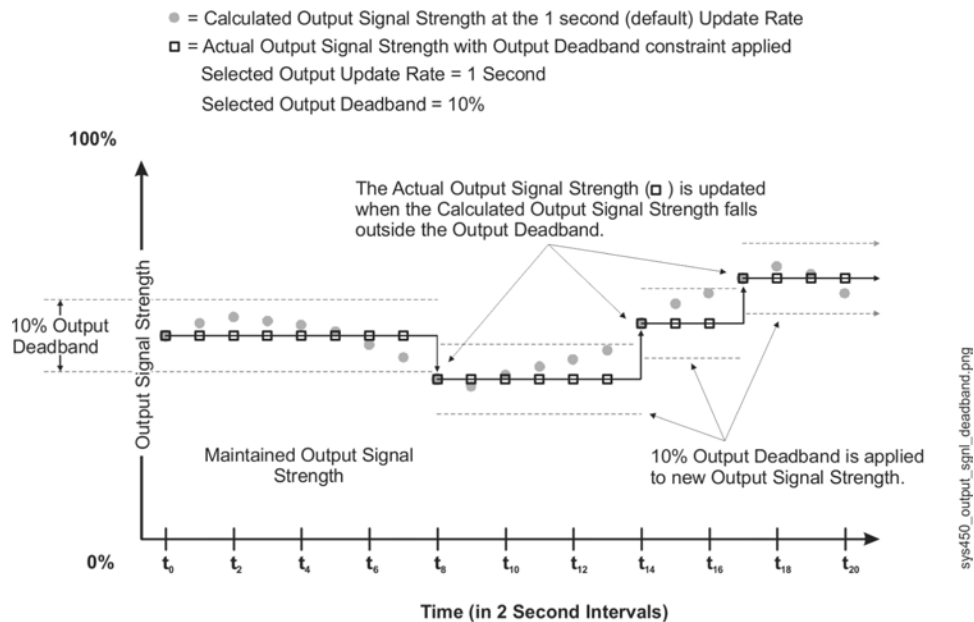

The Output Deadband feature can be used in conjunction with the Output Update Rate feature, but care must be taken when selecting these values for your control system. In process loops where the condition (temperature, pressure, or humidity) value can change quickly over a large range, the delay in updating the actual output signal strength can cause the controlled equipment to oscillate out of range and drive the process away from the desired setpoint. After selecting new Output Update Rate and Output Deadband values, observe your controlled system through several cycles to determine the affect of the new values. If the calculated output signal strength is 0 or 100%, the actual output signal strength changes immediately.

High input signal selection

The High Input Signal Selection feature enables a System 450 control system to monitor a temperature, pressure, or humidity condition with two or three sensors of the same type and control relay and analog outputs based on the highest condition value sensed by the two or three referenced sensors.

When Sn-1 and Sn-2 are set up with the same Sensor Type, the functional High Input Signal Selection sensor (HI-2) is available for selection when you set up the outputs in the control system. When Sn-1, Sn-2, and Sn-3 are set up with the same Sensor Type, the functional sensor (HI-3) is also available for selection.

① **Note:** Setting up Sn-1 and Sn-2 as the same Sensor Types also enables the functional Differential Control sensor (Sn-d). See [Differential Control](#) for more information.

High Input Signal Selection control application examples include:

- fan-staging control on multi-circuit condensing units
- fan motor speed control on multi-circuit condensing units

Differential control

The Differential Control feature enables a System 450 control system to monitor and maintain a temperature, pressure, or humidity differential between two sensors of the same type and control

relay, analog outputs, or both based on the sensed differential value relative to user-selected differential values.

Differential Control application examples include:

- solar heating systems
- pump pressure-drop monitoring and control
- fluid filter pressure-drop monitoring
- air filter pressure-drop monitoring

Setting up an output (relay or analog) for Differential Control requires connecting two identical sensors to input terminals Sn1 and Sn2 and selecting the same Sensor Type in the System 450 UI for Sensor 1 (Sn-1) and Sensor 2 (Sn-2). The System 450 control system recognizes the same Sensor Types and makes the functional Differential Control sensor (Sn-d) available for selection when you set up each of the control system outputs.

① **Note:** Setting up Sn-1 and Sn-2 as the same Sensor Types also enables the functional High Input Signal Selection sensor (HI-2). See [High Input Signal Selection](#) for more information.

When a Differential Control sensor (Sn-d) is set up, the differential sensor value is always equal to Sn-1 minus Sn-2. Therefore, depending on the intended control action of the output, the differential value may be either a positive or negative value.

The sensed differential value (Sn-d) between Sn-1 and Sn-2 is displayed in the System Status screens as either a temperature differential value (dIFT), pressure differential value (dIFP), or humidity differential value (dIFH). The unit of measurement associated with the displayed differential value is determined by the Sn-1 and Sn-2 Sensor Type. See Table 5 for Sensor Types and their units of measurement.

When a relay output is set up for Differential Control, System 450 compares the sensed differential value, Sn-d ($Sn-d = Sn-1 \text{ minus } Sn-2$), to the user-selected differential values (dON and dOFF) to control the relay's On/Off state.

When an analog output is set up for Differential Control, System 450 compares the sensed differential value, Sn-d ($Sn-d = Sn-1 \text{ minus } Sn-2$), to the user-selected differential values (dSP and dEP) to control the analog output signal strength.

① **Note:** Because of the way that the System 450 Differential Sensor (Sn-d) is set up and calculated using two sensors with identical Sensor Types, the Range of Usable Values for each Sensor Type is twice as large as a single sensor. (Each Sensor Type has an equal number of positive and negative values on outputs that reference Sn-d.) See Table 5 for a Sensor Type's Range of Usable Values when an output references Sn-d.

Table 5: Range of usable values for sensor types in differential control applications

Sensor type	Sn-d range of usable values	Sensor type	Sn-d range of usable values
°F	-290 to 290	P 30	-30.0 to 30.0
°C	-161.0 to 161.0	P 50	-50.0 to 50.0
rH	-95 to 95	P 100	-100.0 to 100.0
P 0.25	-0.500 to 0.500	P 110	-110.0 to 110.0
P 0.5	-0.500 to 0.500	P 200	-200 to 200
P 2.5	-2.50 to 2.50	P 500	-500 to 500
P 5	-5.00 to 5.00	P 750	-750 to 750
P 8	-9.00 to 9.00	HI°F	-380 to 380
P 10	-10.00 to 10.00	HI°C	-210.0 to 210.0
P 15	-16.0 to 16.0	--	--

Sensor Failure mode

System 450 allows you to select the mode of operation for your control system outputs in the event of a sensor (or sensor wiring) failure of the sensor or sensors that the outputs reference. When you set up an output in the System 450 UI, you must select a sensor failure mode of operation in the Sensor Failure Mode (SNF) screen. Your selection determines how an output responds if a referenced sensor or the sensor wiring fails.

System 450 outputs can be set up to directly reference a single compatible sensor hardwired to the control system (Sn-1, Sn-2, or Sn-3). Outputs in control systems with System 450 standard control modules can also be set up to reference several functional sensors (Sn-d, HI-2, or HI-3). The functional sensors reference input from one or more of the hard-wired sensors; thus one or more of the hard-wired sensors can influence the outputs that reference functional sensors.

When any one of the connected sensors (Sn-1, Sn-2, or Sn-3) or associated sensor wiring fails, all of the outputs that reference the failed sensor, either directly or through a functional sensor, go into the outputs' selected sensor failure modes and continue to operate in the sensor failure modes until the sensor or sensor wire failure is corrected.

You can select either On or OFF for an output's Sensor Failure Mode. Depending on the type of output (relay or analog), the On and OFF Sensor Failure Modes are defined as follows:

- Relay output SNF On = Relay On. See [Relay Outputs](#) for more information about a relay output's On state.
- Relay output SNF OFF = Relay OFF. See [Relay Outputs](#) for more information about a relay output's Off state.
- Analog output SNF On = Output Signal Strength at End Point (OEP). See [Direct and Reverse Control Actions for Analog Outputs](#) for more information about Output Signal at End Point.
- Analog output SNF OFF = Output Signal Strength at Setpoint (OSP). See [Direct and Reverse Control Actions for Analog Outputs](#) for more information about Output Signal at Setpoint.

System 450 control system examples

With System 450 control and expansion modules, you can build a wide variety of cost-effective, custom control systems. Each of the following examples provide an illustration of the module assembly, including wiring diagrams for system sensors and outputs, and menu flow charts showing typical Main screens and System Status screens, along with System Setup screens and example setup values.

Note: The physical configurations, wiring, and setup values shown in the following examples are meant to illustrate typical control system applications, control features, and system setup values. Your control applications may require different modules, module configurations, sensors, wiring, and UI setup parameters and values.

See [Control Module and User Interface](#) and [Expansion Modules, Module Assemblies, and Outputs](#) for general information and guidelines about System 450 modules and UI. See Figure 10 for information and procedures about how to design your control system, select modules and sensors, mount and wire your control system, access and navigate the System 450 UI, and set up your control system in the UI.

Control system example

The following table shows an example System 450 control system module assembly and the (user-installed) field wiring for a cooling application with condenser fan speed control. Figure 11 shows the System 450 UI menu flow for monitoring and setting up the control application shown in Figure 10.

Figure 12 shows a temperature, humidity, and pressure System 450 control system example, the module positions, the output types, and the automatically assigned output numbers used in the System Setup screens in the control module UI. Figure 13 shows the corresponding Main, System Status, and Setup Screens.

Figure 14 shows a System 450 control system example for a solar water heating and storage application that uses the Differential Control feature to control two circulation pumps. Figure 15 shows the corresponding Main, System Status, and Setup Screens.

Figure 10: Example of a System 450 control showing for a room heating and cooling application with condenser fan speed control

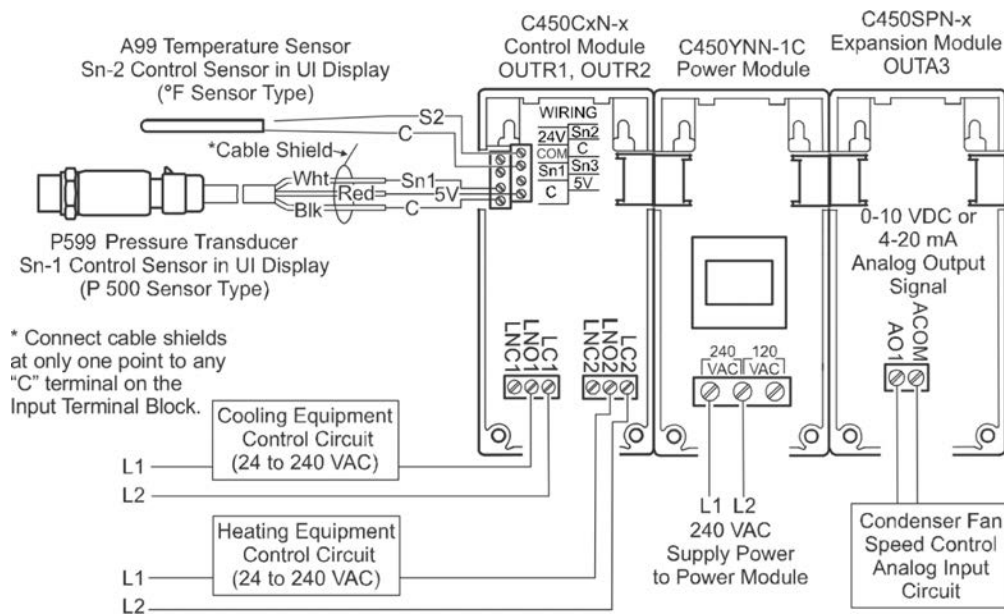

Figure 11: Main, System, Status, and Setup Screens for a room heating and cooling application with condenser fan speed control

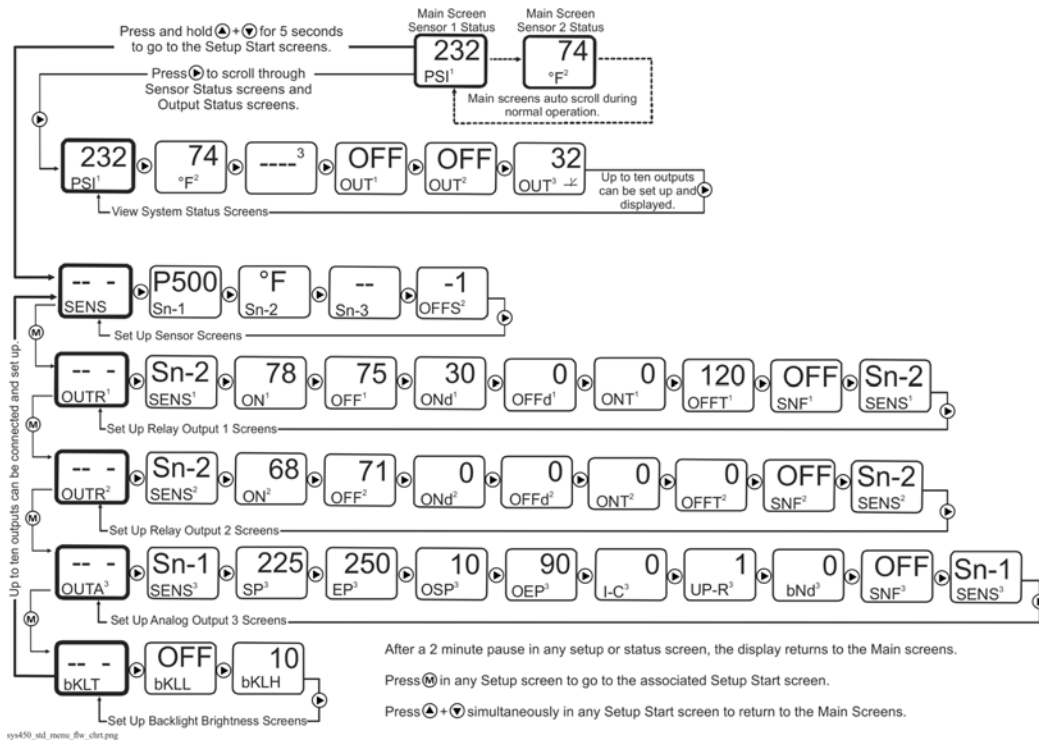

Figure 12: Example of a System 450 standard control for a clean room application that controls temperature, pressure, and humidity simultaneously

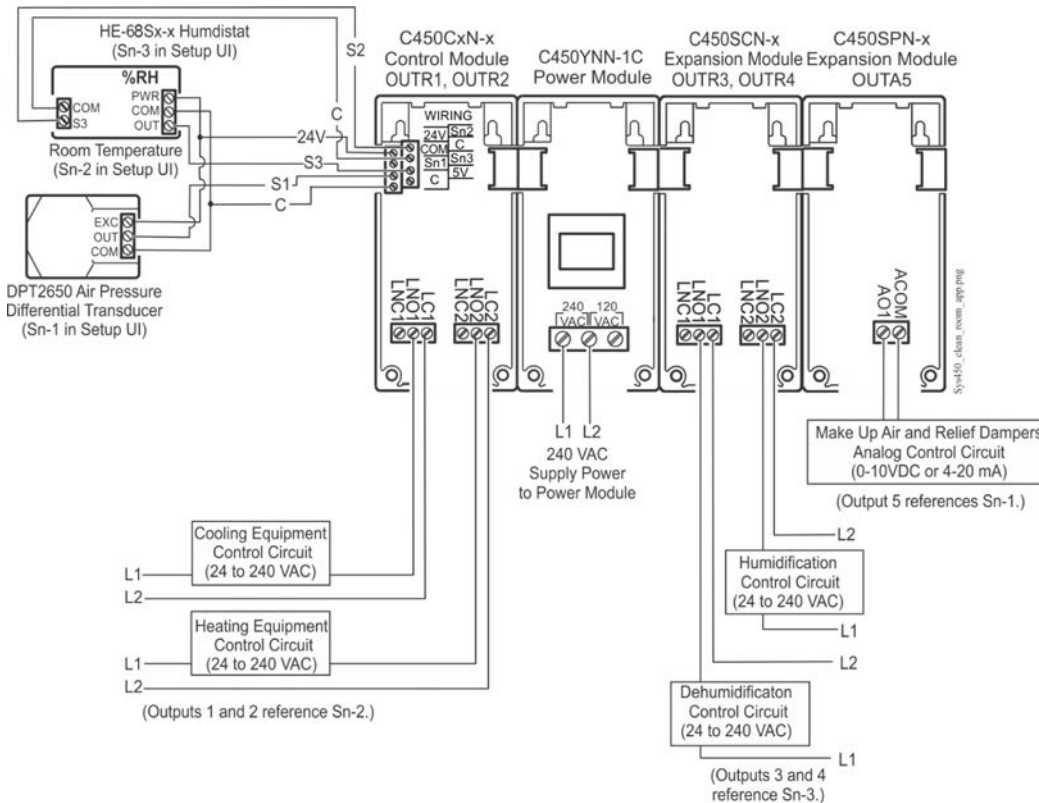

Figure 13: Main, System Status, and Setup Screens for a clean room application that controls temperature, pressure, and Humidity Simultaneously

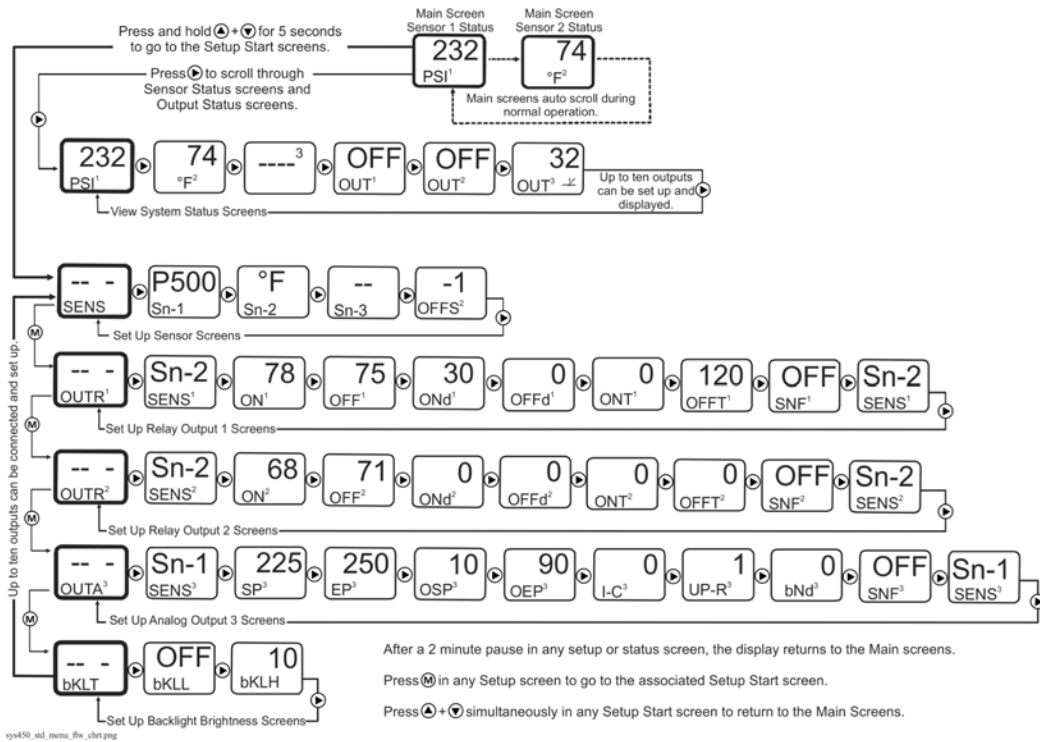

Figure 14: Example System 450 standard control showing a solar water space heating application that uses the differential control feature

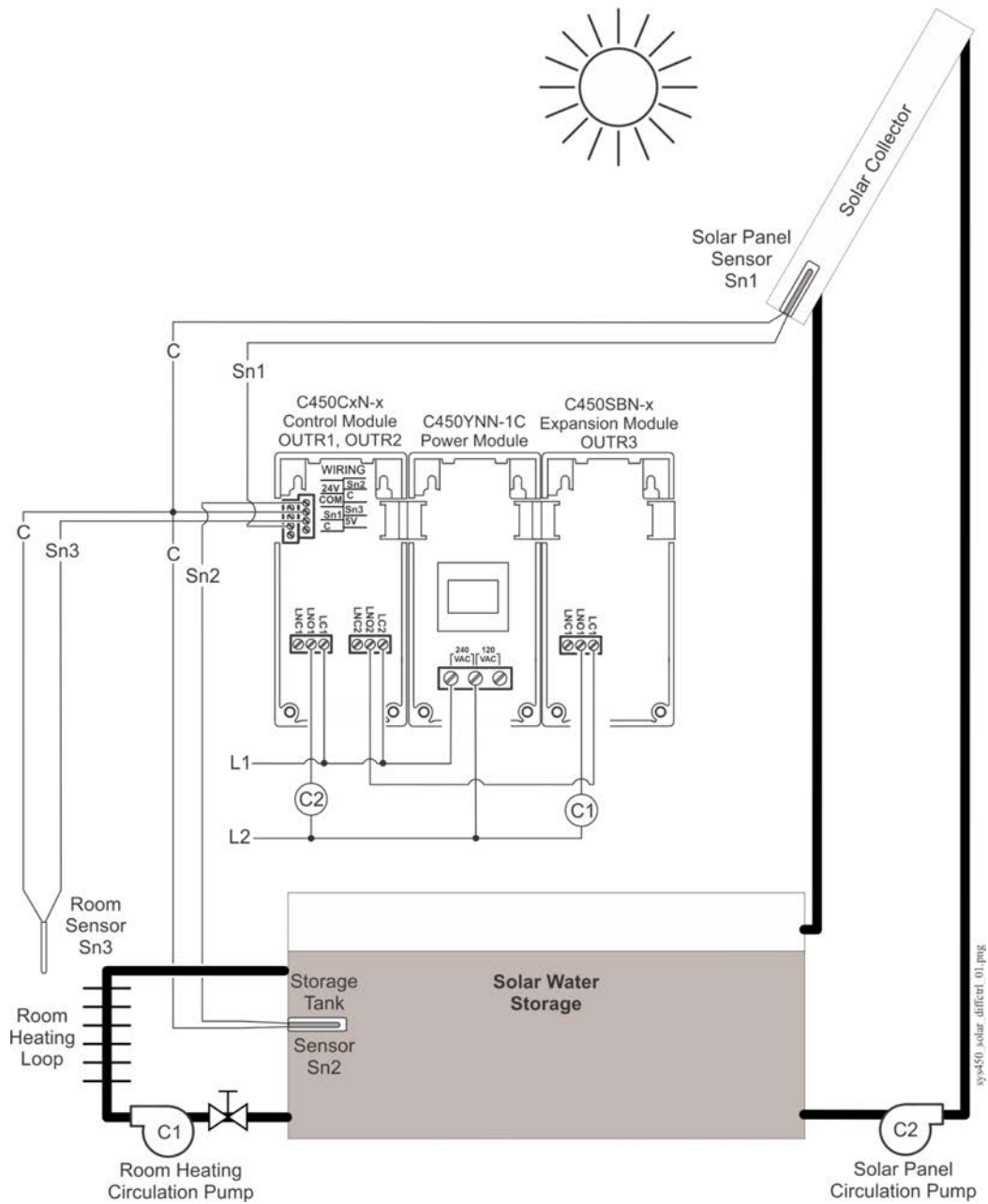
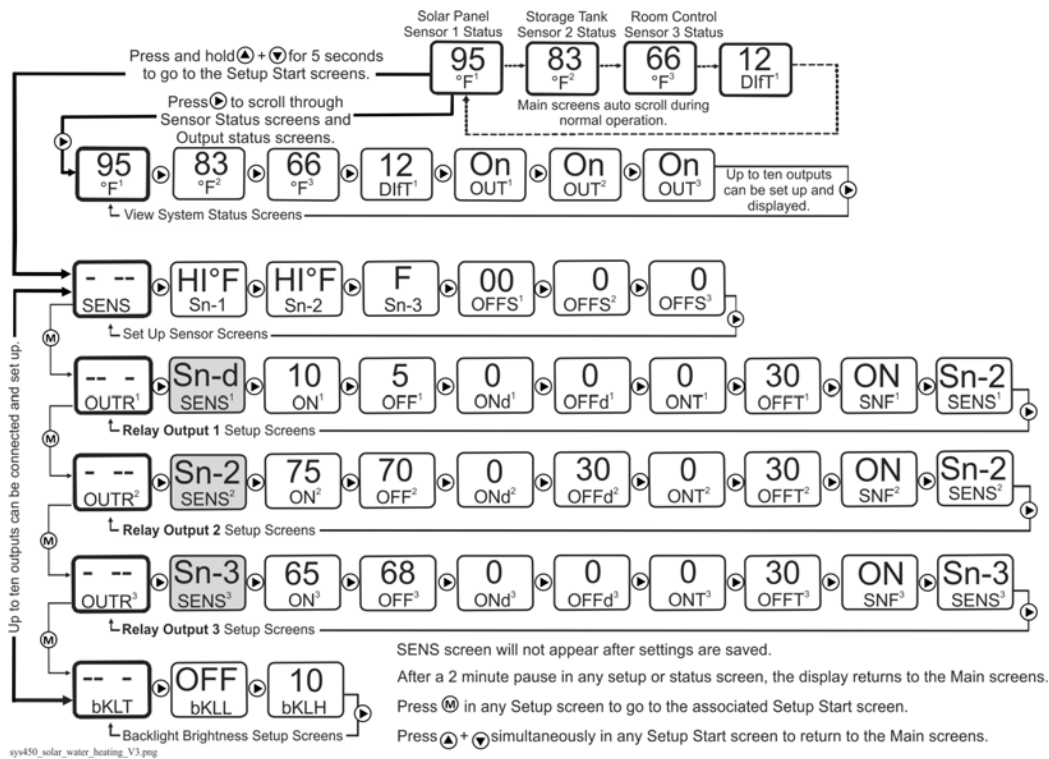

Figure 15: Main, System Status, and Setup Screens for a solar water heating control system example that uses the differential control feature



Hybrid analog and high input signal selection control system example

Figure 16 shows a System 450 Hybrid Analog Output Control System example using a C450CPW-400 control module with the hybrid analog output controlling the speed of the Electronically Commutated (EC) fan motor for cooling based on condenser pressure.

This example uses two P599 Pressure Transducers and the High Input Signal Selection feature to control the condenser fan speed based on the highest pressure sensed by the two transducers. The cooling equipment is controlled by an A99 temperature sensor.

Figure 16 also shows a C450 control system that is set up to use the High Input Signal Selection feature to control the hybrid analog output signal and the motor speed of an EC fan motor on the cooling equipment condenser.

Figure 17 shows the System 450 UI Main screens, System Status screens, and System Setup screens for the control system example in Figure 16.

Figure 16: System 450 hybrid analog output control system example with condenser fan (EC) motor speed control, high input signal selection

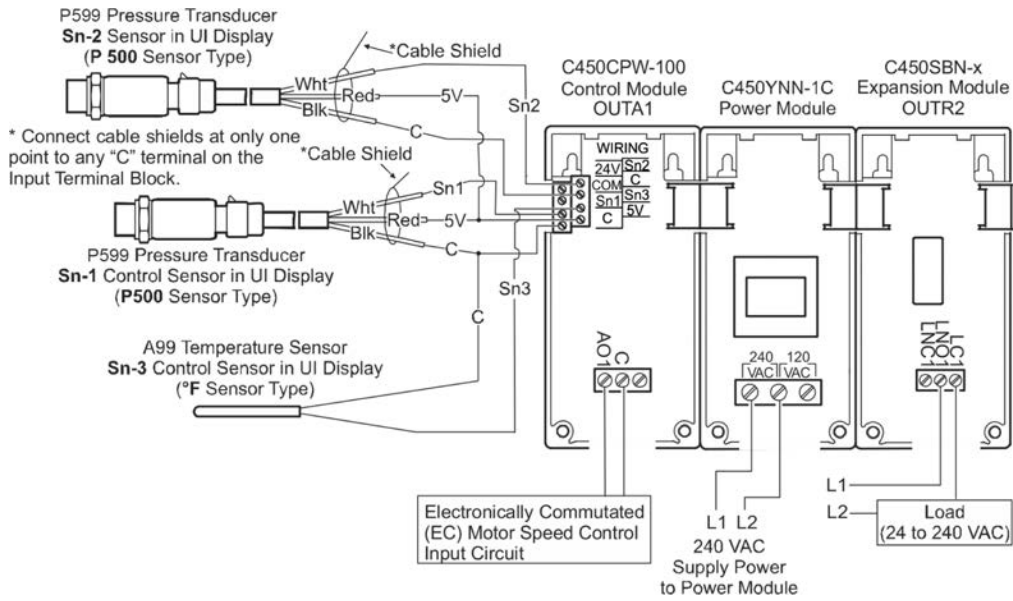
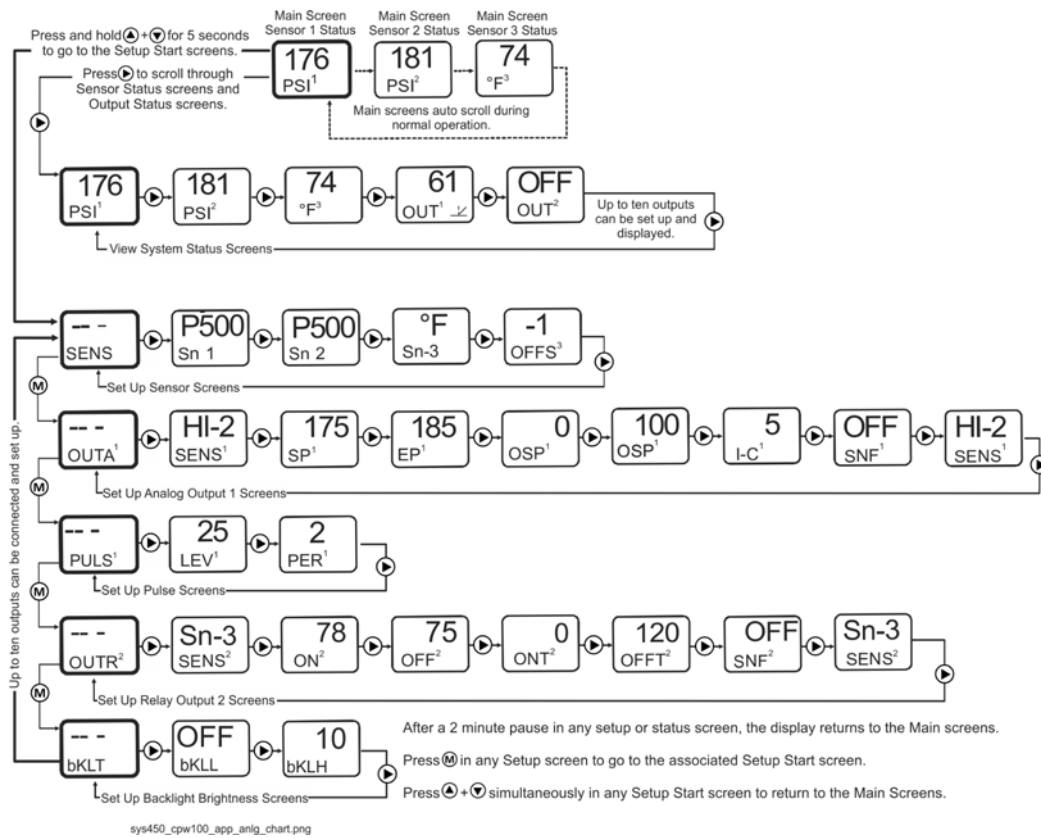

Figure 17: Main, System Status, and Setup Screens for a hybrid analog output control system example with high input signal selection



Designing and building System 450 control systems

The variety and flexibility of System 450 modules and sensors allow you to build an almost limitless variety of custom control systems. In fact, for many control systems, different System 450 components can be configured to achieve the same results.

Observe the following guidelines when designing a control system and selecting components for your control system:

- Determine the conditions and condition ranges that must be monitored and controlled in your application to determine the sensors you need. Up to three sensors can be connected and up to three conditions can be monitored simultaneously using standard control modules. See Table 2 and [Selecting, Installing, and Setting Up Sensors](#) for more information.
 - Determine the type of control your application requires—standard control, relay control, analog proportional control, Differential Control, High Input Signal Selection, multi-purpose, or a combination of control types. See [System 450 Control Systems with Standard Control Modules](#) for more information regarding System 450 control types.
 - Select the standard control module or hybrid analog output control module if your application requires on/off relay control, proportional analog control, multi-stage control, multi-purpose control, stand-alone control, or proportional plus integral control. (See Table 12 for System 450 control module model information.)
 - Determine the number and type (relay or analog) of outputs required to control the equipment in your application. Up to ten outputs can be configured and controlled by a single System 450 control module.
 - Determine the types of control and expansion modules (relay or analog) needed to provide the required outputs for your application and the minimum number of modules required to provide those outputs.
- ① **Note:** Many System 450 control systems can be configured using different combinations of module models to build the assembly, but typically there is one combination of modules that is more cost effective to build than other potential module assembly configurations.

Selecting, installing, and setting up sensors

In a System 450 control system, all of the outputs reference one or more of the sensors that are wired to the control module and set up in the control module UI. Observe the following guidelines when you select, install, and set up sensors for your control system:

- Select only System 450 compatible sensors. See Table 5 for a complete list of System 450 sensor types and models that are compatible with standard control modules. See Table 14 through Table 18 in [Repair and Ordering Information](#) for more information about System 450 compatible sensors.
- Select only the sensors that match the desired conditions and units of measurement, and are designed to operate in the ranges that your control system is intended to monitor and control.
- Ensure that the correct sensor is wired properly to the correct input terminals on the control module. See [Wiring System 450 Components](#).
- Ensure that the wire length between the sensors and control module is as short as possible or practical, and ensure that the wiring is properly sized. Refer to the sensor installation instructions referenced in [System 450 Overview](#) for more information on wiring sensors.

- Ensure that the correct sensor type is selected in the System 450 UI for each sensor wired to the control module. See [Setting Up the Sensors and Transducers](#).
- Ensure that each output references the correct sensor in the System 450 UI. See [Setting up a System 450 Control System](#).

Assembling System 450 modules

After selecting the System 450 components for your control system, you must assemble the modules. Figure 2 shows an example of a System 450 module assembly.

Observe the following guidelines when assembling System 450 modules:

- Always locate the control module on the left side of the module assembly.
- Always plug the System 450 power module when used into the right side of the control module.
- Plug the expansion modules together, in any order, on the right side of the System 450 power module or on the right side of the control module when an external 24 V power supply is used instead of a System 450 power module. See [Wiring System 450 Components](#) for information on wiring an optional external 24 VAC supply power to System 450 control systems that do not include a power module.

Locating System 450 modules

Observe these guidelines when locating and mounting System 450 modules:

- Ensure that the mounting surface can support the module assembly, DIN rail, mounting hardware, and any user-supplied panel or enclosure.
- Mount the modules in a horizontal, upright orientation wherever possible. DIN rail mounting is strongly recommended.
- In direct-mount applications, mount the modules on flat and even surfaces.
- Mount the modules in a location free of corrosive vapors and observe the ambient operating conditions in the [Related Documentation](#).
- Leave sufficient space for making connections, running wires, and viewing the LCD.
- Do not mount the modules on surfaces that are prone to vibration or in locations where high-voltage relays and motor-starters, electromagnetic emissions, or strong radio frequency may cause interference.
- Do not install heat generating devices in an enclosure with the modules that may cause the ambient temperature to exceed 66°C (150°F).

Mounting

Mount System 450 modules on 35 mm DIN rail (recommended) or directly to a flat, even surface.

Mounting modules on DIN rail

About this task: To mount the modules on DIN rail, complete the following steps:

1. Provide a section of 35 mm DIN rail that is longer than the module assembly width, and mount the DIN rail in a suitable location using appropriate mounting hardware.

2. Clip the control module on the rail, position the module's upper DIN rail clips on the top rail, and gently snap the lower clips on to the bottom of the rail.
- **Important:** When mounting a module assembly on a DIN rail, clip the modules on to the DIN rail individually before gently sliding and plugging the mounted modules together on the DIN rail. Clipping a complete module assembly that is already plugged together on to the DIN rail can damage the 6-pin modular plugs and void any warranties.
3. Clip the remaining modules to the right of the control module on to the DIN rail and gently slide and plug the modules together. If a System 450 power module is used, mount the power module on the right side of the control module so that the power module plugs directly into the control module.

Direct-mounting modules

About this task:

To direct-mount modules to walls and other flat surfaces using the four keyhole slots, complete the following steps:

1. Plug the modules together, remove the module covers, place the module assembly horizontally against the wall surface in a suitable location, and mark the mount hole locations on the mounting surface
2. Install appropriate screws or fasteners, leaving the screw heads approximately one to two turns away from flush to the mounting surface.
3. Position the assembly mounting slots over the screw heads, and then carefully tighten the mounting screws to secure the assembly to the surface.

- ⓘ **Note:** If you mount the modules on an uneven surface, use shims or washers to mount module assembly evenly on the surface.

Refer to the sensor installation instructions referenced in [System 450 Overview](#) for information on locating and mounting System 450 compatible sensors.

Wiring System 450 components

When wiring your System 450 control system, observe the following guidelines. See Figure 18, Figure 19, and Figure 20 for wiring terminal locations and designations. See [Related Documentation](#) for the electrical ratings for System 450 modules used to built System 450 standard control systems.

WARNING

Risk of Electric Shock

Disconnect or isolate all power supplies before making electrical connections. More than one disconnection or isolation may be required to completely de-energize equipment. Contact with components carrying hazardous voltage can cause electric shock and may result in severe personal injury or death.

AVERTISSEMENT

Risque de décharge électrique

Débrancher ou isoler toute alimentation avant de réaliser un branchement électrique. Plusieurs isolations et débranchements sont peut-être nécessaires pour couper entièrement l'alimentation de l'équipement. Tout contact avec des composants conducteurs de tensions dangereuses risque d'entraîner une décharge électrique et de provoquer des blessures graves, voire mortelles.

- **Important:** Use copper conductors only. Make all wiring connections in accordance with local, national, and regional regulations. Do not exceed the System 450 module's electrical ratings.
- **Important:** Do not exceed the System 450 module electrical ratings. Exceeding module electrical ratings can result in permanent damage to the modules and void any warranty.
- **Important:** Run all low-voltage wiring and cables separate from all high-voltage wiring. Shielded cable is strongly recommended for input (sensor) and analog output cables that are exposed to high electromagnetic or radio frequency noise.
- **Important:** Make all wiring connections in accordance with the National Electrical Code and local regulations. Use proper Electrostatic Discharge (ESD) precautions during installation and servicing to avoid damaging the electronic circuits of the System 450 modules.
- **Important:** Do not connect supply power to the System 450 modules before checking all wiring connections. Short circuits or improperly connected wires can result in damage to the modules and void any warranty.
- **Important:** A System 450 control module and module assembly can be connected to an internal power source (a System 450 power module) or an external power source (24 V power connected to the 24V and COM terminals on the control module), but must not be connected to both power sources simultaneously. Connecting a control module to both internal and external power sources can damage the modules and void any warranty.

- Important:** When connecting System 450 compatible sensors with shielded cable to a System 450 control module, connect the cable shield drain lead to one of the C (common) terminals on the input sensor terminal block. Do not connect the shield at any other point along the cable. Isolate and insulate the shield drain at the sensor end of the cable. Connecting a cable shield at more than one point can enable transient currents to flow through the sensor cable shield, which can cause erratic control operation.

Figure 18 and Figure 19 show the locations of and designations for the wiring terminals for System 450 standard control modules and expansion modules.

Figure 18: Wiring Terminal Details for System 450 Control and Expansion Modules with Relay Output

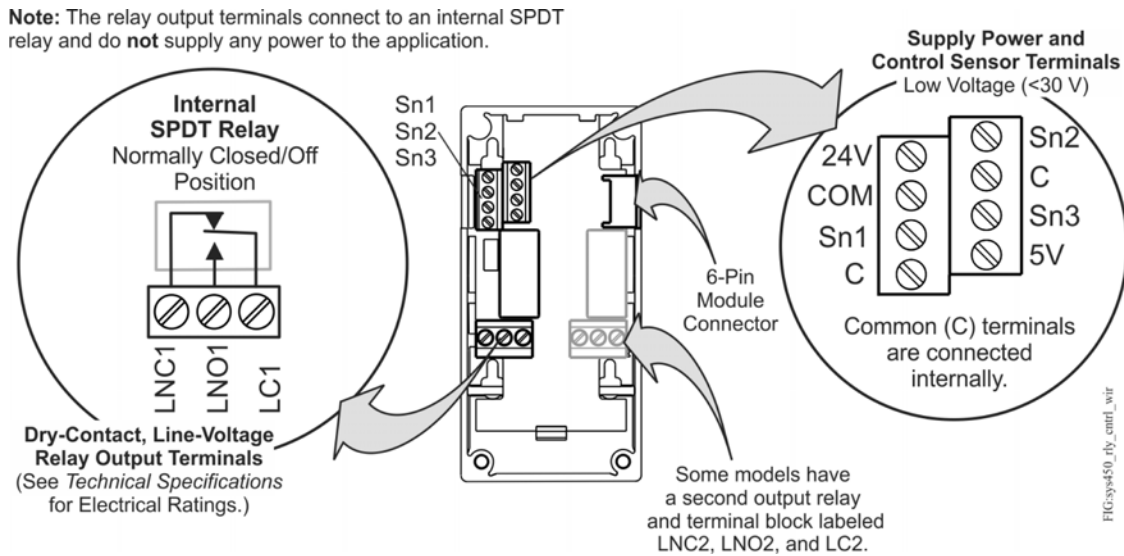

Figure 19: Wiring Terminal Details for System 450 Control and Expansion Modules with Analog Outputs

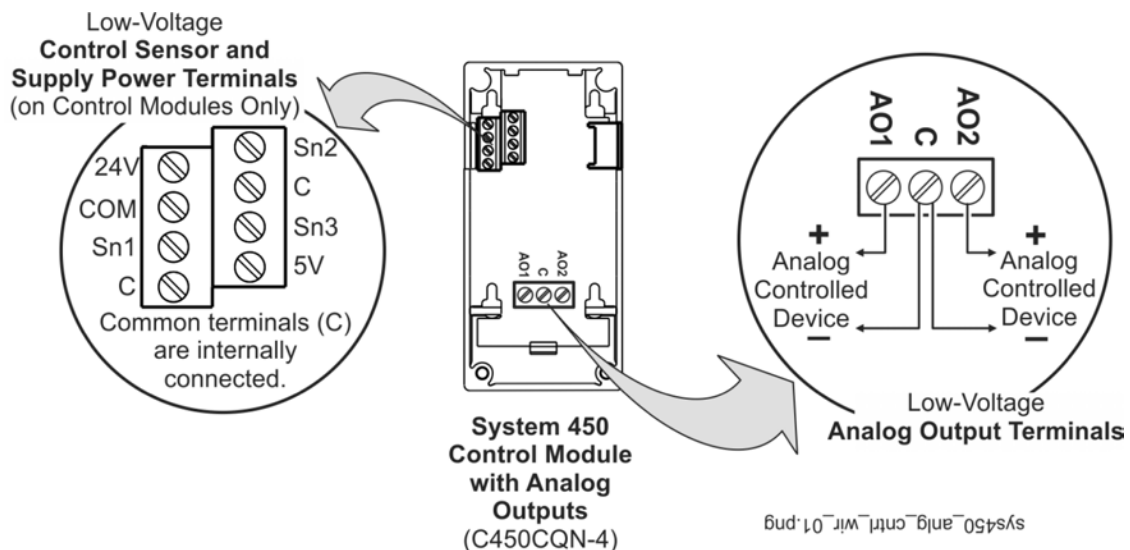

Table 6 provides descriptions, ratings, requirements, and recommended cable types and recommended wire sizes for System 450 standard control, expansion, and power modules.

Table 6: System 450 wiring terminal and wire size information

Terminal block type on module type	Terminal label	Terminal function	Required wire sizes
Sensor and low-voltage supply power terminal block on all control modules	24 V	Provides power terminal for active 24VAC humidity sensors when a C450YNN power module is connected.	0.08 mm ² to 1.5 mm ² 28 AWG to 16 AWG
	5 V	Provides 5 VDC power for active sensors.	
	Sn1, Sn2, Sn3	Accepts passive or active input signals from sensors.	
	C	Provides low-voltage common connections for passive or active sensors connected to the 5V, Sn1, Sn2, and Sn3 terminals. ⓘ Note: The terminals are connected internally.	
	COM	Provides low-voltage common connections for 24 VAC power connected to the 5V, Sn1, Sn2, and Sn3 terminals. ⓘ Note: The terminals are connected internally.	
Line-voltage output relay terminal blocks on control and expansion modules with relay output)	LNC1, LNC2	Connects equipment control circuit to the line-voltage Normally Closed (LNC) contact on the SPDT relay. LNC2 terminals are only on control and expansion modules with two output relays.	0.08 mm ² to 2.5 mm ² 28 AWG to 14 AWG
	LNO1, LNO2	Connects equipment control circuit to the line-voltage Normally Open (LNO) contact on the SPDT relay. LNO2 terminals are only on control and expansion modules with two output relays.	
	LC1, LC2	Connects line power to the line-voltage Common (LC) on the SPDT relay. LC2 terminals are only on control and expansion modules with two output relays.	
Low-voltage analog output terminal block on control and expansion modules with analog outputs	AO1, AO2	In conjunction with the COM terminal, provides a self-detecting analog output signal; either 0 to 10 VDC or 4 to 20 mA.	0.08 mm ² to 1.5 mm ² 28 AWG to 16 AWG
	ACOM	In conjunction with the AO1 or AO2 terminal, provides a self-detecting analog output signal; either 0 to 10 VDC or 4 to 20 mA.	
Line-voltage supply power terminal block on power modules only	240 VAC	Left terminal is for one 240 VAC supply power lead.	0.34 mm ² to 2.5 mm ² 22 AWG to 14 AWG
	No Label on the Middle Terminal	Middle terminal is the Common connection for either the 120 VAC or 240 VAC supply power lead.	
	120 VAC	Right terminal is for one 120 VAC supply power lead.	

Figure 20 shows the location of and designations for the wiring terminals on a C450YNN-1C power module. Table 7 provides descriptions, ratings, requirements, and recommended wire sizes for a C450YNN-1C power module.

Figure 20: System 450 C450YNN-1C Power Module showing high-voltage supply power terminals

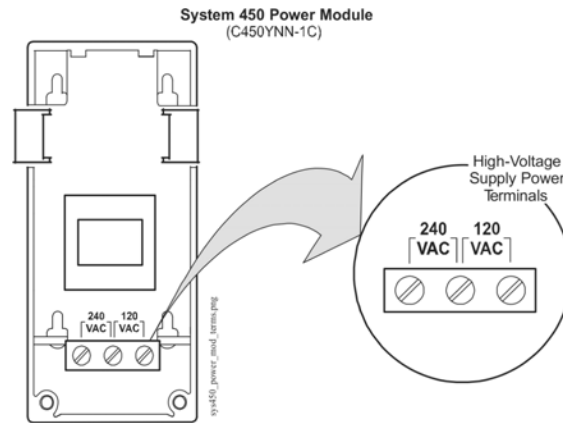

Table 7: System 450 Power Module wiring terminal and wire size information

Terminal block type on module type	Terminal label	Terminal function	Required wire sizes
Line-voltage supply power terminal block on power modules	240 VAC	Left terminal is for one 240 VAC supply power lead.	0.34 mm ² to 2.5 mm ² 22 AWG to 14 AWG
	No Label on the Middle Terminal	Middle terminal is the Common connection for either the 120 VAC or 240 VAC supply power lead.	
	120 VAC	Right terminal is for one 120 VAC supply power lead.	

Wiring System 450 sensors and transducers

Refer to the sensor installation instructions referenced in [System 450 Overview](#) for information on wiring System 450 compatible sensors.

Setting up a System 450 control system

After assembling the modules, your System 450 control system is ready to connect to power and to be set up in the control module UI.

- You can power on and set up your System 450 control system in the control module UI before installing the module assembly or wiring the sensors and outputs.
- The sensors or transducers must be set up in the System 450 UI before you can set up any of the control system outputs. See [Setting Up the Sensors and Transducers](#) for more information and detailed procedures.

Determining output numbers and output types

After all of the modules in your control system are properly assembled and each time power is supplied to the module assembly, the control module automatically polls all of the modules in the assembly, assigns output numbers, and determines output types and their order in the assembly.

The control module assigns a sequential output number to each output in the module assembly, starting with the output farthest to the left in the module assembly, which is assigned output number 1. Each output to the right of output 1 is assigned an output number; the numbers are 2 to 9 in order of the output's physical position, left to right, in the module assembly. Zero (0) is assigned to output 10, if the control system has ten outputs. See Figure 2 for an example of output numbers in a module assembly.

The control module also determines if an output is a relay output or an analog output, and generates the appropriate status screens and setup screens in the System 450 UI for each output.

- **Important:** Do not change the module positions after a System 450 control system is assembled, powered, and set up in the System 450 UI. System 450 control logic is set up in the UI according to the Sensor Type, Output Type, and Output Number. If you change the module positions in a module assembly that is already set up in the UI, the output numbers and default setup values for the outputs also change, which often requires you to set up the entire control system in the UI again.

System 450 UI navigation guidelines

See the example menu flowchart in Figure 3 and the following general guidelines for information on navigating the System 450 UI on the standard control modules.

- During normal operation, the Main screens (sensor status screens) auto-scroll, displaying the control system's sensor statuses on the LCD.
- While the Main screens are auto scrolling on the LCD, press **Next** (repeatedly) to manually scroll through the sensor status and output status screens.
- While the Main screens are auto scrolling on the LCD, press and hold **Up** and **Down** simultaneously for 5 seconds to go to the Sensor Setup Start screen and access the rest of the System Setup screens.
- While in any System Setup Start screen, press **M** repeatedly to scroll through the System Setup Start screens for your control system. You cannot type values in System Setup Start screens.
- You must set up the sensors before you can set up the outputs. See [Setting Up the Sensors and Transducers](#) for procedures for setting up the sensors.
- An output's type (relay or analog) and output's ID number in the UI is determined by the output types on the control module and any connected expansion modules and the order in which the modules are connected in the module assembly. See [Module Assemblies, Output Types, and Output Numbers](#) for more information.
- An output's setup parameters are determined by the output's type (relay or analog) and the Sensor Type of the sensor you select for the output to reference. See [Expansion Modules, Module Assemblies, and Outputs](#) and [System 450 Control System Examples](#) for more information.
- In System Setup screens with flashing values, you can change the parameter value by pressing **Up** or **Down**. When the desired parameter value is flashing in the setup screen, press **Next** to save the selected value and go to the next setup screen.
- After 2 minutes of inactivity in a System Status or System Setup screen, the LCD reverts back to the Main screens.

Accessing and navigating the UI

System 450 control modules feature a backlit LCD and a four-button touchpad UI for monitoring system status and setting up the sensors and outputs in your control system. Figure 1 describes the System 450 UI features and functions.

During normal operation, the System 450 control module LCD displays the Main screens. The Main screens are the sensor status screens, which scroll automatically and provide real-time status of the conditions sensed at the hard-wired and functional sensors.

Figure 21 shows an example of the System 450 Main screens and System Status screens.

Viewing the System Status screens

From the Main screens, you can scroll through and view the System Status screens.

To view the system status screens, while the control module LCD is auto-scrolling through Main screens, press **Next** (repeatedly) to scroll through and display the Sensor Status screens and the Output Status screens for all sensors and outputs set up in your control system.

When you stop pressing **Next**, the Sensor or Output Status screen that is being viewed is displayed for 2 minutes before it times out and reverts to the Main screens. The 2-minute pause allows you to monitor a sensor that is changing quickly during system setup or normal system operation.

System 450 Main screens display the status at the hard-wired Sn-1, Sn-2, and Sn-3 sensors, and the statuses of the functional sensor Sn-d when used in the control system. The System Status screens also display hard-wired and functional sensor statuses along with output statuses.

Figure 21 shows the Main screens (sensor status) and the System Status screens (sensor and output status) for a standard System 450 control system that is set up for differential pressure control.

Figure 21: Main screens and system status screens example for a standard System 450 control system set up for differential control

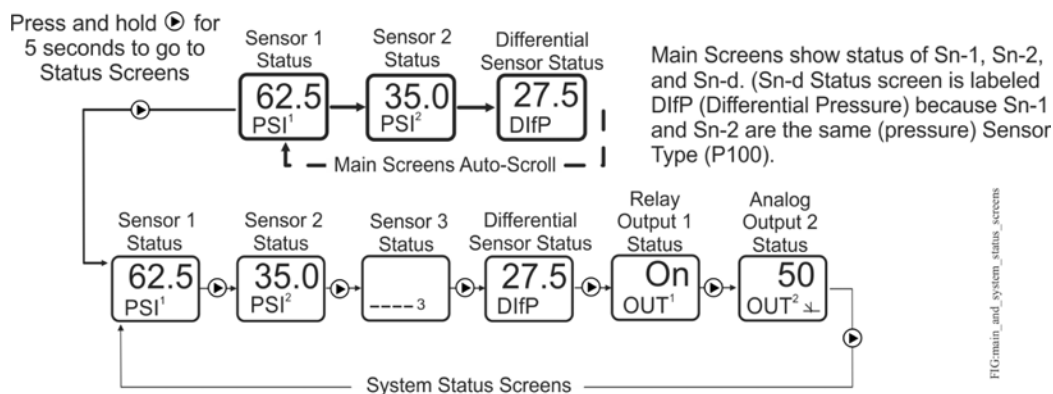

Accessing the System Setup screens

From the Main screens, you can also access the Sensor Setup Start screen and the Output Setup Start screens.

- From the Sensor Setup Start screen, you can set up all of the hard-wired sensors for your control system. See [Setting Up the Sensors and Transducers](#) for procedures on setting up the sensors and transducers.)
- From the Output Setup Start screens, you can set up each output in your control system. See [Setting up a Relay Output](#) and [Setting up an Analog Output](#) for procedures on setting up outputs.)

In this task you access and navigate the System 450 Setup Start screens.

1. In the **Main** screens, press **Up** and **Down** simultaneously and hold for five seconds. The **Sensor Setup Start (SENS)** screen appears (Figure 22).

Figure 22: Accessing the Setup Start screens in the System 450 UI

After a 2 minute pause in any setup or status screen, the display returns to the Main screens.

Press **M** in any Setup screen to go to the associated Setup Start screen.

Press **▲** + **▼** simultaneously in any Setup Start screen to return to the Main screens

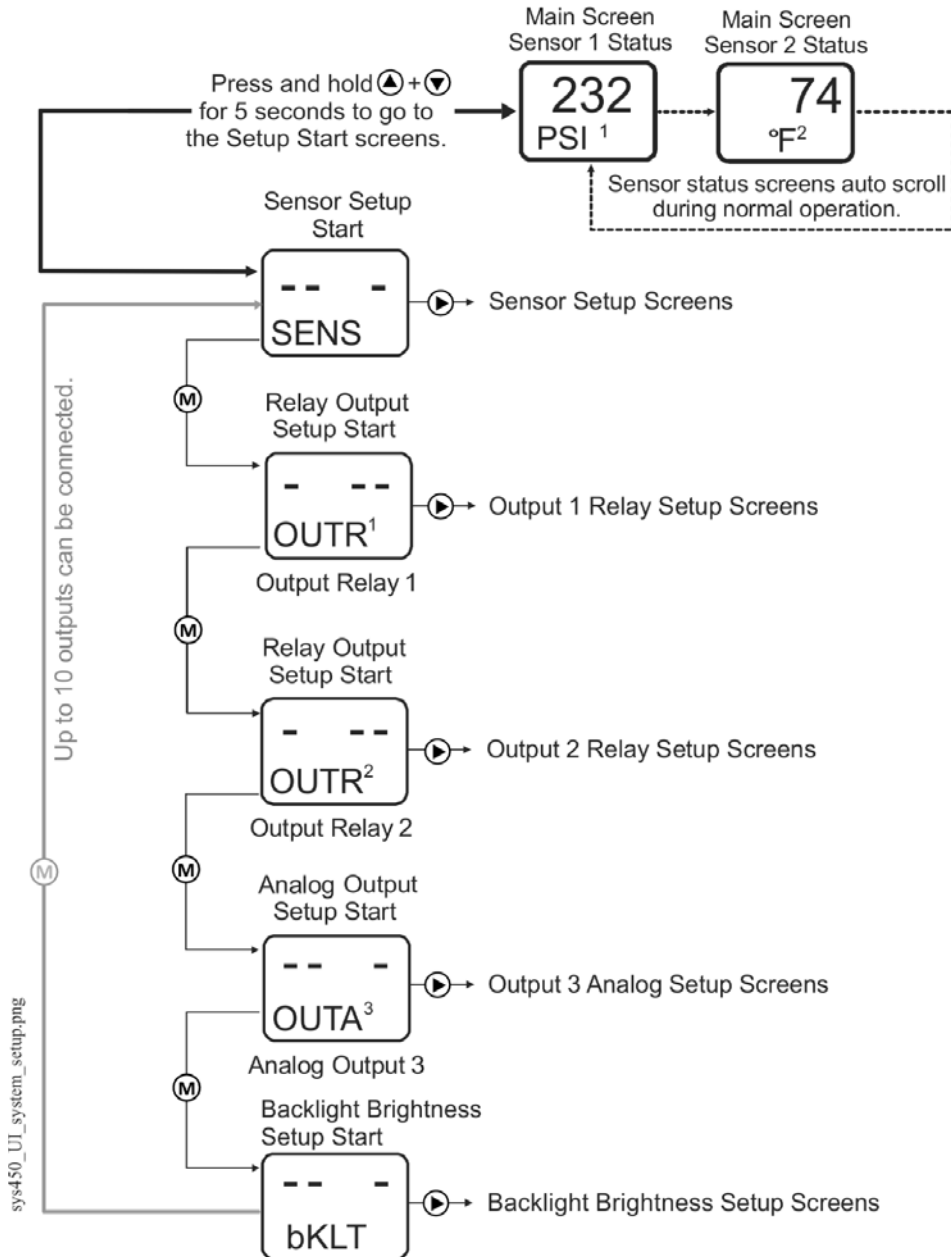

2. Press **M** (repeatedly) to scroll through and access the **Output Setup Start (OUTXⁱ)** screens for all of the outputs in your control system.

① **Note:** All Setup Start screens have four flashing dashes in the setup value fields. You cannot enter values for the fields in the Setup Start screens.

3. Depending on the Setup Start screen that you have navigated to, press **Next**:

- in the **Sensor Setup Start (SENS)** screen to go the **Select Sensor 1 Type (Sn-1)** screen and set up the sensors in your control system. See [Setting Up the Sensors and Transducers](#) for procedures on setting up the hard-wired sensors and transducers.

- in any **Output Setup Start (OUTX[†])** screen to go to the first output setup screen for the output. (See [Setting up a relay output](#) or [Setting up an analog output](#) for the procedures for setting up outputs.)

① **Note:** You must set up the sensors and transducers in the System 450 UI before you can set up the outputs in the UI.

In any of the system setup screens, press **M** to return to the setup start screen. In the setup start screen, press **Up** and **Down** simultaneously or wait two minutes to return to the Main screens.

Setting up the sensors and transducers

To set up the sensors and transducers in your control system, you must select the correct Sensor Type in the System 450 UI for each sensor and transducer used in your application. You can also select an optional temperature offset value for any temperature sensor that is set up in your control system.

① **Note:** System 450 compatible sensors consist of temperature sensors, humidity sensors, and pressure transducers. The term sensor refers to all System 450 compatible input devices including transducers, unless noted otherwise.

The Sensor Type you select for a sensor or transducer automatically determines the condition type, unit of measurement, minimum differential, setup value ranges, and default setup values for each output in your control system that references the sensor.

System 450 control modules do the following:

- support specified temperature sensors, pressure transducers, and humidity sensors
- support binary inputs (a external set of dry contacts) connected to input sensor terminals (Sn1, Sn2, or Sn3 and C)
- support configuration of Sn-1, Sn-2, and Sn-3 as any supported Sensor Type
- support the functional sensors HI-2 and HI-3 and the High Input Signal Selection feature
- support the functional sensor Sn-d and the Differential Control feature
- require Sn-1 and Sn-2 to be the same Sensor Type to set up the functional sensors HI-2 and Sn-d
- require Sn-1, Sn-2, and Sn-3 to be the same Sensor Type to set up the functional sensor HI-3 (in addition to HI-2 and Sn-d)

① **Note:** For a System 450 control system to operate properly, you must wire the correct sensor or transducer model to the correct sensor input terminals on the control module, and select the correct Sensor Type in the associated Select Sensor Type screen in the System 450 UI. See Table 2 for System 450 Sensor Types and their associated values and settings.

See Table 14 through Table 23 in [Repair and ordering information](#) for more information on System 450 compatible sensors.

System 450 allows you to select an offset for each temperature sensor (only) in your control system. Whenever you select the °F or °C Sensor Type for a sensor, a Select Temperature Offset screen appears after the Select Sensor 3 Type screen for each temperature sensor in your control system.

The Select Temperature Offset screens are:

- Sensor Type °F, which enables an offset of up to +/- 5°F in 1-degree increments.
- Sensor Type °C, which enables an offset of up to +/- 2.5°C in 0.5-degree increments.

The temperature offset adjusts the displayed temperature value, sensed at the sensor, by the offset value. For example, if the measured value is 72(°F) without an offset, and a -2(°F) offset is selected, the measured value is offset -2(°F) and the displayed value is 70(°F).

In this task you set up the sensor's Sensor Type and offsets for the temperature sensors as follows:

1. Access the System 450 UI and navigate to the Sensor Setup Start (SENS) screen (Figure 23).
2. In the **Sensor Setup Start (SENS)** screen, press **Next** to go to the next screen.

Figure 23: Sensor Setup Start, Select Sensor Type, and Select Temperature Offset screens

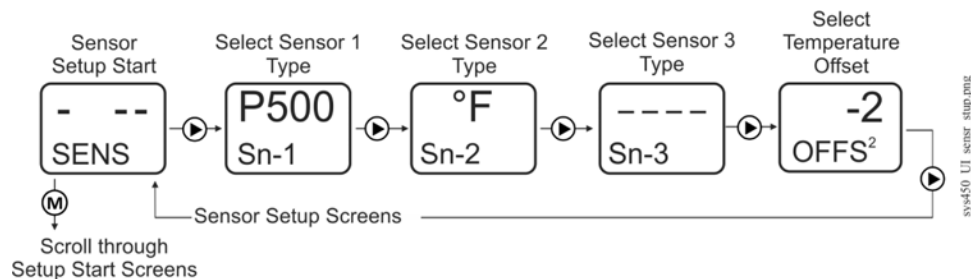

3. In the **Select Sensor 1 Type (Sn-1)** screen, press **Up** or **Down** to scroll through the Sensor Types. When the desired Sensor Type is displayed (blinking), press **Next** to save the Sensor Type selection and go to the Select Sensor 2 Type screen.
4. Repeat [Step 3](#) in the **Select Sensor 2 Type (Sn-2)** screen and **Select Sensor 3 Type (Sn-3)** screen if your control system uses a second or third sensor.

After you have selected the correct Sensor Type for each sensor in your control system, the sensors are set up in the UI and can be selected and referenced by the outputs that you set up in the system.

- ⓘ **Note:** System 450 standard control modules provide for three functional sensors. When Sn-1 and Sn-2 are set up as the same Sensor Type, the High Input Signal Selection functional sensor (HI-2) and Differential Control functional sensor (Sn-d) are enabled and available in the Sensor Selection screens for each output. When Sn-1, Sn-2, and Sn-3 are the same Sensor Type, the High Input Signal Selection functional sensor (HI-3) is also enabled and available. See [High Input Signal Selection](#) and [Differential Control](#) for more information on these functional sensors and the associated control features.
5. If a temperature Sensor Type (°F or °C) is selected for a sensor in your control system, a **Select Temperature Offset (OFFS²)** screen is displayed after the **Select Sensor 3 Type (Sn-3)** screen (for each temperature sensor in your control system). Select the desired temperature offset by pressing **Up** or **Down**. Press **Next** to save the offset value and go to the next screen.

6. After all of the sensors and temperature offsets are set up:
 - Press **Next** to return to the **Sensor Setup Start (SENS)** screen; then press **M** to scroll through the output setup start screens and set up the outputs in your control system. (See [Setting up Control System Outputs](#) for procedures on setting up outputs for your control module.)
 - Allow the UI to remain dormant for 2 minutes and the Main screen begins to autoscroll. You may also return to the Main screen by pressing **Up** and **Down** simultaneously while a Setup Start screen is displayed.

Setting up control system outputs

After setting up the sensors for your System 450 control system, you can reference the hard-wired sensors and any functional sensors that resulted from the hard-wire sensor setup as you set up the outputs.

Relay output setup

Relay Outputs provide single and multiple stage on/off control to controlled equipment. A Relay Output can be set up to be a direct-acting relay or reverse-acting relay (Figure 24 and Figure 25). See [Relay Outputs](#) for more information about System 450 Relay Output operation and the relay ON and OFF states.

Figure 24: Direct-acting relay (OFF < ON) set up to control cooling

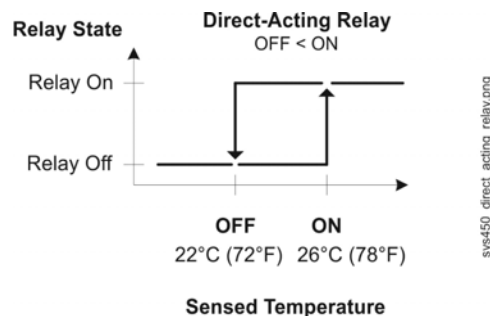
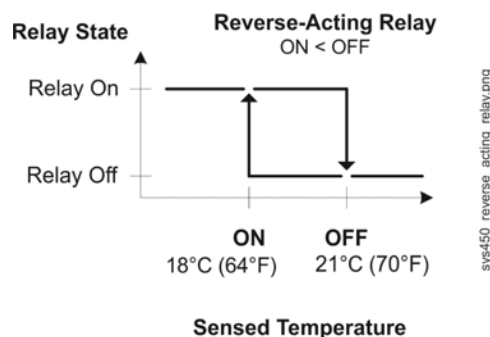

Figure 25: Reverse-acting relay (ON < OFF) set up to control heating



When you supply power to a module assembly, the control module polls all of the connected modules, detects all of the outputs in the module assembly, then assigns an output number to each output, and enables a **Relay Output Setup Start (OUTR[®])** screen for each relay output detected (Figure 26).

The first screen in the relay output setup menu flow is the **Sensor Selection (SENS^x)** screen. The sensor you select (Sn-1, Sn-2, Sn-3, HI-2, HI-3, or Sn-d) in this screen determines the Sensor Type parameter ranges and values available in the remaining output setup screens.

① **Note:** The condition (temperature, pressure, or humidity), unit of measurement, minimum differential value, default setup values, and condition value ranges available in the output setup screens are determined by the Sensor Type for the sensor that an output references. See Table 5 for more information on sensors that are compatible with System 450 standard control modules, their Sensor Types, and the values and ranges associated with each Sensor Type.

The Relay ON and Relay OFF parameters allow you to select the condition values at which the relay turns on and turns off. The first time you access the Relay ON (ON^x) and Relay OFF (OFF^x) screens, the default ON and OFF values for the referenced sensor appear.

① **Note:** If you select a sensor (Sn-1, Sn-2, or Sn-3) that is set up as a binary input, the ON and OFF selections screens do not appear in the Relay Output Setup screens. The relay ON and OFF state is controlled by the binary input state. See [Binary Input Control for Relay Outputs](#) for more information.

The minimum differential value for the condition is determined by the Sensor Type of the sensor that an output references. The minimum differential is fixed and is automatically enforced in the setup UI when you select ON and OFF values. After you select the ON value, the condition values within the minimum differential range are not available to select. See Table 5 for minimum differential ranges.

The ON Delay Time and OFF Delay Time parameters allow you to set a time (0 to 300 seconds) to delay the relay from going On or Off after the ON or OFF value is reached. See [Relay On and Off Duration Control](#) for more information.

The Minimum Relay ON Time and Minimum Relay OFF Time parameters allow you to set a minimum time (0 to 300 seconds) that the relay stays On or Off after the ON or OFF value is reached. See [Relay On and Off Duration Control](#) for more information.

The Sensor Failure Mode parameter allows you to select whether the output relay is on or off if the referenced sensor encounters a sensor or wiring failure. See [Sensor Failure Mode](#) for more information.

Figure 26: Relay output setup start screen and setup screen flow

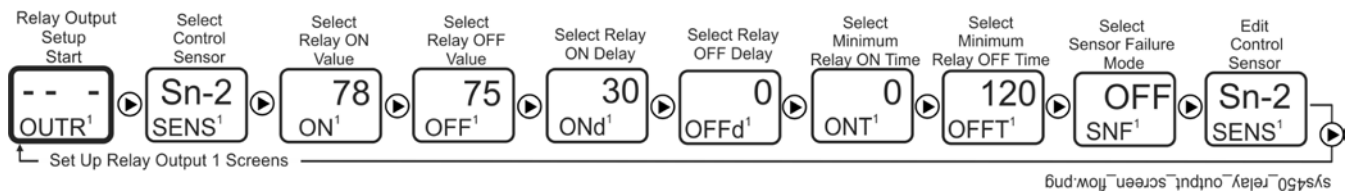

Setting up a relay output

About this task: To set up a relay output, complete the following steps:

1. Access the System 450 UI and navigate to the desired **Relay Output Setup Start (OUTR^x)** screen (Figure 26). See [Accessing and Navigating the User Interface](#).
2. In the **Relay Output Setup Start (OUTR^x)** screen, press **Next** to go to the **Select Sensor (SENS^x)** screen. The Select Sensor screen does not appear here if a sensor is already selected for this output. In that case, go to the next step. Press **Up** or **Down** to select the hard-wired or functional sensor (Sn-1, Sn-2, Sn-3, Sn-d, HI-2, or HI-3) that the output references. Press **Next** to save the sensor selection and go to the next screen.

3. In the **Select Relay ON Value (ON^x)** screen, press **Up** or **Down** to select the temperature, pressure, or humidity value at which the relay turns On. Press **Next** to save the ON value and go to the next screen.
 - ⓘ **Note:** If you selected the **Sn-d** sensor in Step 2, the **Select Relay Differential ON Value (dON^x)** screen is displayed. Press **Up** or **Down** to select the temperature, pressure, or humidity differential value at which the relay turns On. Press **Next** to save the dON value and go to next screen. See [Differential Control](#) for more information.
4. In the **Select Relay OFF Value (OFF^x)** screen, press **Up** or **Down** to select the temperature, pressure, or humidity value at which the relay turns Off. Press **Next** to save the OFF value and go to the next screen.
 - ⓘ **Note:** If you selected the **Sn-d** sensor in Step 2, the **Select Relay Differential OFF Value (dOFF^x)** screen is displayed. Press **Up** or **Down** to select the temperature, pressure, or humidity differential value at which the relay turns OFF. Press **Next** to save the dOFF value and go to the next screen. See [Differential Control](#) for more information.
5. In the **Select ON Time Delay (ONd^x)** screen, press **Up** or **Down** to select the number of seconds that the relay output delays going to the On state after the Relay ON (or dON) value is reached. Press **Next** to save the ONd value and go to the next screen. See [Relay On and Off Duration Control](#) for more information.
6. In the **Select OFF Time Delay (OFFd^x)** screen, press **Up** or **Down** to select the number of seconds that the relay output delays going to the OFF state after the Relay OFF (or dOFF) value is reached. Press **Next** to save the OFFd value and go to the next screen. See [Relay On and Off Duration Control](#) for more information.
7. In the **Select Minimum Relay ON Time (ONT^x)** screen, press **Up** or **Down** to select the minimum number of seconds that the relay remains On after the Relay goes ON. Press **Next** to save the ONT value and go to the next screen. See [Relay On and Off Duration Control](#) for more information.
8. In the **Select Minimum Relay OFF Time (OFFT^x)** screen, press **Up** or **Down** to select the minimum number of seconds that the relay remains Off after the Relay goes OFF. Press **Next** to save the OFFT value and go to the next screen. See [Relay On and Off Duration Control](#) for more information.
9. In the **Select Sensor Failure Mode (SNF^x)** screen, press **Up** or **Down** to select whether the output relay stays on or off when a sensor failure is detected. Press **Next** to save the Sensor Failure Mode value and go to the next screen.
10. In the **Edit Sensor (SENS^x)** screen, if the displayed sensor (Sn-1, Sn-2, Sn-3, Sn-d, HI-2, or HI-3) is the correct sensor for the output relay, the output setup is complete. Press **Next** to return to the Relay Output Setup Start screen.
11. In the **Edit Sensor (SENS^x)** screen, if the displayed sensor (Sn-1, Sn-2, Sn-3, Sn-d, HI-2, or HI-3) is not the correct sensor for the output relay, press **Up** or **Down** to select the correct sensor. Press **Next** to save the new sensor selection and go to the Relay Output Setup Start screen. Press **Next** again to go to the Relay ON Value screen and repeat Step 3 through Step 10 for the new sensor.

Result The relay output is set up and saved in the control module. If you need to set up the next output, press **M** to navigate to the next Output Setup Start screen. If you have completed your control system setup, press **Up** and **Down** simultaneously or wait two minutes to return to the Main screens.

Analog output setup

Analog Outputs provide proportional analog control signals to controlled equipment based on the sensed conditions. See [Analog Outputs](#) for more information.

When you supply power to a module assembly, the control module polls all of the connected modules, detects all of the outputs in the module assembly, then assigns an output number to each output, and enables an **Analog Output Setup Start (OUTA^x)** screen for each analog output detected (Figure 29). See [Analog Outputs](#) for more information.

- ① **Note:** The condition (temperature, pressure, or humidity), unit of measurement, minimum differential value, default setup values, and condition value ranges available in the output setup screens are determined by the Sensor Type of the sensor that you select for the output. See Table 5 for more information on sensors that are compatible with System 450 standard control modules, their Sensor Types, and the values and ranges associated with each Sensor Type.

The Setpoint (SP) and End Point (EP) parameters allow you to set up a proportional band (or throttling range) for the control loops in your controlled system.

The Output at Setpoint (OSP) and Output at End Point (OEP) parameters allow you to select the output signal strength (as a percentage of the total signal strength range) that an analog output sends to the controlled equipment at Setpoint and End Point.

Figure 27: Relationship between setpoint, end point, output at setpoint, and output at end point for an Analog Output that controls room heating

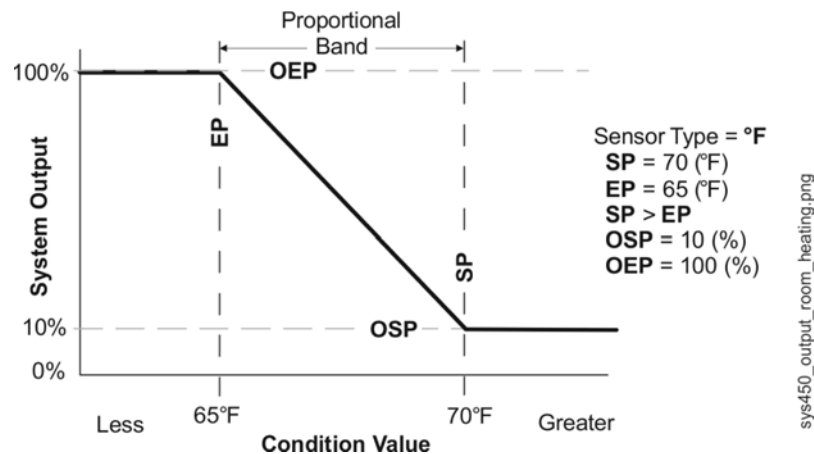
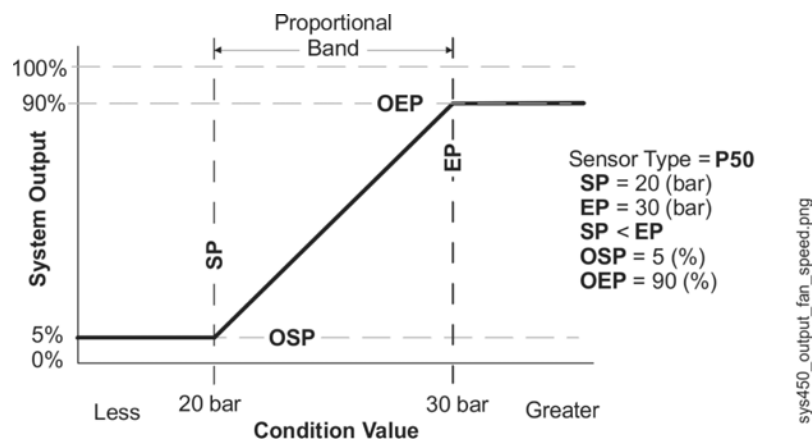

Figure 28: Relationship between Setpoint, End Point, Output at Setpoint, and Output at End Point for an Analog Output That Controls Condenser Fan Speed



The relationship between these four setup values (SP, EP, OSP, and OEP) determines the analog output’s proportional control action, which is indicated on the control module LCD by the control ramp indicator. See Figure 1 and [Direct and Reverse Control Actions for Analog Outputs](#) for more information on the control ramp indicator.

- ① **Note:** System 450 analog outputs that reference the differential control sensor (Sn-d) use a Differential Setpoint (dSP) and Differential End Point (dEP) to define the output’s proportional band. See [Differential Control](#) for more information.

The Integration Constant (I-C) parameter allows you to select an integration constant for the analog signal. Selecting an integration constant other than 0 enables proportional plus integral control action, which in many applications can drive the condition closer to setpoint (than proportional-only control action). See [Proportional Plus Integral Control and Integration Constants](#) for more information. See [Determining the Integration Constant for an Analog Output](#) for procedures on determining and testing the integration constants in your control application.

The Output Signal Update Rate screen and the Output Signal Deadband screen allow you to reduce the rate at which an analog output updates the output signal strength, reducing wear on controlled equipment such as actuators. See [Analog Output Update Limiters](#) and [Analog Output Deadband](#) for more information.

The Sensor Failure Mode (SNF) parameter allows you to select whether the analog output signal is off, corresponding to the lowest output capacity, or on, corresponding to the highest output capacity when a sensor failure is detected. See [Sensor Failure Mode](#) for more information.

Figure 29: Analog Output setup start screen and setup screens flow

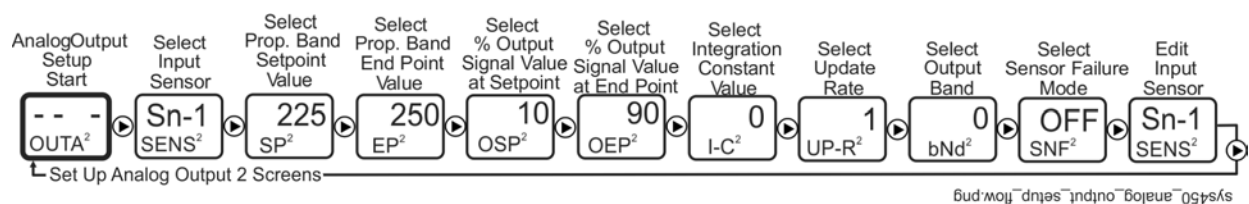

Setting up an analog output

About this task:

In any of the system setup screens, press **M** to return to the setup start screen. In the setup start screen, press **Up** and **Down** simultaneously or wait two minutes to return to the Main screens. In this task you set up an analog output.

1. Access the System 450 UI and navigate to the desired **Analog Output Setup Start (OUTA^x)** screen (Figure 29). See [Accessing and Navigating the User Interface](#) for information on accessing the System Setup screens.
2. In the **Analog Output Setup Start (OUTA^x)** screen, press **Next** to go to the **Select Sensor (SENS^x)** screen. The Select Sensor screen does not appear here if the sensor is already selected for this output. In that case, go to the next step. Press **Up** or **Down** to select the hard-wired or functional sensor (Sn-1, Sn-2, Sn-3, Sn-d, HI-2, or HI-3) that the output references. Press **Next** to save the sensor selection and go to the Select Setpoint Value screen.
3. In the **Select Setpoint Value (SP^x)** screen, press **Up** or **Down** to select the Setpoint value. The controlled system drives towards Setpoint [SP] and away from End Point [EP], which together define the proportional band for the analog output. Press **Next** to save the Setpoint value and go to the next screen.
 - ⓘ **Note:** If you selected the **Sn-d** sensor in Step 2, the **Select Differential Setpoint Value (dSP^x)** screen is displayed. Press **Up** or **Down** to select the temperature, pressure, or humidity differential value towards which the controlled system is driving. Press **Next** to save the dSP value and go to the **Select Differential End Point Value (dEP^x)** screen. See [Differential Control](#) for more information.
4. In the **Select End Point Value (EP^x)** screen, press **Up** or **Down** to select the End Point value. The controlled system operates between Setpoint and End Point, which together define the proportional band for the analog output. Press **Next** to save the End Point value and go to the next screen.
 - ⓘ **Note:** If you selected the **Sn-d** sensor in Step 2, the **Select Differential End Point Value (dEP^x)** screen is displayed, press **Up** or **Down** to select the differential End Point value. The controlled system operates between differential Setpoint and differential End Point, which together define the proportional band for the analog output. Press **Next** to save the dEP value and go to the next screen. See [Differential Control](#) for more information.
5. In the **Select Output Signal Strength at Setpoint (OSP^x)** screen, press **Up** or **Down** to select the value in percent of the output signal strength (0 to 100%), corresponding to the lowest output capacity, when the sensor is at Setpoint (SP^x). Press **Next** to save the displayed OSP value and go to the next screen.
6. In the **Select Output Signal Strength at End Point (OEP^x)** screen, press **Up** or **Down** to select the value in percent of the output signal strength (0 to 100%), corresponding to the highest output capacity, when the sensor is at the End Point (EP^x). Press **Next** to save the displayed OEP value and go to the next screen.
7. In the **Select Integration Constant (I-C^x)** screen, press **Up** or **Down** to select the integration constant value for the analog output. See [Determining the Integration Constant for an Analog Output](#) for more information. Press **Next** to save the displayed I-C value and go to the next screen.
8. In the **Select Output Signal Update Rate (UP-R^x)** screen, press **Up** or **Down** to select the output update rate value. One (second) is the default value. You can select a value between 1 and 240 seconds. See [Analog Output Update Limiters](#) for more information. Press **Next** to save the output update rate value and go to the next screen.

9. In the **Select Output Signal Deadband (bNd^x)** screen, press **Up** or **Down** to select the output deadband value as a percentage of the total output signal range. Zero (percent) is the default value. You can select a value between 0 and 50 (percent). See [Analog Output Deadband](#) for more information. Press **Next** to save the output deadband value and go to the next screen.
10. In the **Select Sensor Failure Mode (SNF^x)** screen, press **Up** or **Down** to select whether the analog output signal is to be set to its ON or OFF value when a failure of the referenced sensor is detected. When sensor that is referenced by analog output fails, the ON value sets the output to the OEP value and the OFF value sets the output to the OSP value. Press **Next** to save the displayed SNF value and go to the next screen.
11. In the **Edit Sensor (SENS^x)** screen, you can change the hard-wired or functional sensor that the output currently references.
 - a. If the displayed sensor (Sn-1, Sn-2, Sn-3, Sn-d, HI-2, or HI-3) is the correct sensor for the output relay, the output setup is complete. Press **Next** to go to the Analog Output Setup Start screen.
 - b. If the displayed sensor (Sn-1, Sn-2, Sn-3, Sn-d, HI-2, or HI-3) is not the correct sensor for the output relay, press **Up** or **Down** to select the correct sensor. Press **Next** to save the new sensor selection and go to the Analog Setpoint Value screen. Repeat Step 3 through Step 10 for the new sensor.
12. When you complete setting up the analog output, press **M** to return to the **Analog Output Setup Start (OUTA^x)** screen.

Result The analog output is set up and saved in the control module.

Pulse region hybrid analog output setup

Figure 30: Pulse region hybrid AO setup start screen

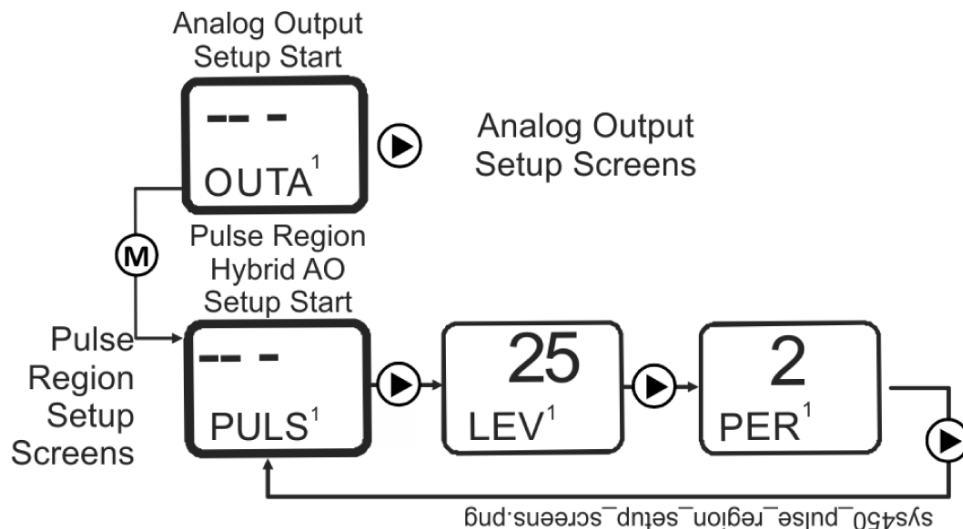

Setting up a pulse region hybrid analog output

About this task:

In this task you set up the Pulse Region of a hybrid analog output for Output 1 on a C450CPW-400 control module.

- From the **Pulse Region Hybrid AO Setup Start Screen (PULS^x)** for Analog Output 1, press **Next** to go to the output's **Pulse Output Level Selection Screen (LEV^x)**.
 - Note:** Only Analog Output 1 (OUTA¹) is capable of generating the Pulse-AO. Additional AO expansion modules provide a standard 0 to 10 VDC or 4 to 20 mA output signal.
- In the **Pulse Output Level Selection Screen (LEV^x)**, set the Pulse Output Level to a (percent) value that is higher than required for the EC Motor to rotate. If the motor requires a minimum speed reference of 2 VDC before it rotates, set the Pulse Level higher than 2.5 VDC (25%). Press **Up** or **Down** to select this Output's Pulse Output Level value. Press **Next** to save the Pulse Output Level value and go to the **Pulse Period Selection Screen (PER^x)**.
 - Note:** Screen example shows the Pulse Output Level set to 25%. Range is 0 to 100%. Set the Pulse Output Level to 0% to disable the pulse output. Set the Pulse Output Level to 100% to use the pulse output over the entire 0 to 10 V output range.
- In the **Pulse Period Selection Screen (PER^x)**, press **Up** or **Down** to select this output's Pulse Period value. Press **Next** to save your Pulse Period value selection and go to the **Pulse Region Hybrid AO Setup Start Screen (PULS^x)**.

Result Screen example shows the Pulse Period set for 2 seconds. Range is 1 to 30 seconds.

Setting up outputs that reference a P 110 sensor

The P 110 Sensor Type can monitor negative pressure down to 20 inHg (-10 psi). When referencing a P 110 sensor, System 450 displays negative pressure values in inHg on the Main and System Status screens. But when you set up an output that references a P 110 sensor and the setup value is a negative pressure value, you must select the pressure value in negative psi (not inHg).

Use Table 8 to determine the negative PSI setup value that corresponds to your inHg target value. For example, if you want a relay output to go off when the sensed pressure reaches 7 inHg, you select the value -3.5 (psi) in the output's Relay OFF Selection screen.

Table 8: inHg target values and equivalent psi setup values

inHg value	psi setup value	inHg value	psi setup value
1	-0.5	11	-5.5
2	-1.0	12	-6.0
3	-1.5	13	-6.5
4	-2.0	14	-7.0
5	-2.5	15	-7.5
6	-3.0	16	-8.0
7	-3.5	17	-8.5
8	-4.0	18	-9.0
9	-4.5	19	-9.5
10	-5.0	20	-10.0

When an output is set up for Differential Control and references the P 110 Sensor Type (Sn-1 and Sn-2 are both P 110 Sensor Type), the sensed negative pressure values displayed in the Main screen for differential pressure status (dIFP) are displayed as negative psi values, not inHg values.

Determining the integration constant for an analog output

The default Integration Constant (I-C) setting for analog outputs is 0 (zero) or no integration constant. An I-C setting of 0 provides a proportional-only analog signal. Most applications do not require you to change this default setting. See [Proportional Plus Integral Control and Integration Constants](#) for more information.

If you want to apply proportional plus integral to a control loop in your controlled system, here are two methods of determining the best I-C setting for the analog output that controls the loop.

- ① **Note:** Both of the following methods for determining an I-C setting require you to install, set up, and operate the control loop in your controlled system under a variety of typical load conditions and observe the response to load changes and different I-C settings.

Testing the slowest to fastest time integral to determine I-C setting

One method of determining the best I-C setting for a control loop is to observe the controlled system's operation at the slowest time integral (I-C setting of 1) and then increase the I-C setting one step at a time to determine the best setting.

In this task you determine the best I-C setting for an analog output by testing slowest to fastest time integral.

1. Set up the System 450 control loop for proportional-only control (I-C setting of 0 [zero]), power the controlled system under typical or steady load conditions, and allow the system to stabilize at a control point somewhere in the proportional band between the Setpoint and End Point values.
2. After the controlled system has stabilized at a control point, set the integration constant to the slowest time integral (I-C setting of 1) and observe the control point to see if it stabilizes closer to the selected Setpoint.
 - If the control point overshoots Setpoint, go to [Step 3](#).
 - If the control point stabilizes closer to Setpoint but does not overshoot Setpoint, set the integration constant to the next (faster) time integral and then observe the control point to see if it stabilizes closer to the selected Setpoint.
 - If the control point does not overshoot Setpoint at new I-C setting, continue to increase the setting and observe the system until the control point overshoots Setpoint, then go to [Step 3](#).
3. When the control point overshoots Setpoint, continue to observe the control point:
 - If the control point drifts past Setpoint, reverses, and then drifts back towards Setpoint and stabilizes at or near Setpoint, go to [Step 4](#).
 - If the control point drives significantly beyond Setpoints, then reverses quickly, drives back past Setpoint, and continues oscillating significantly above and below Setpoint, reset the I-C setting to the previous (slower) time integral and go to [Step 4](#).

4. When the control point stabilizes near Setpoint or drifts slightly above and below Setpoint, operate the control loop under a variety of load conditions, including the maximum load condition:
 - If the control point drives past Setpoint and begins to oscillate significantly above and below Setpoint, reset the I-C setting to the previous (slower) time integral and repeat [Step 3](#).
 - If the control point drifts to or past Setpoint and stabilizes near Setpoint, the current I-C setting for your control loop is correct.

Continue to observe the controlled system until you are sure that the system control point stabilizes somewhere near Setpoint and does not oscillate under all load conditions.

Using the response time to a step change to determine the I-C Setting

About this task:

Another method for determining the best I-C setting for a System 450 control loop is to temporarily create a step change that shifts the proportional band in your controlled system away from the original or desired proportional band. To do so, measure the (first response) time it takes for your controlled system to drive to and stabilize at the shifted control point. Then shift (step change) the proportional band back to original and measure the (second response) time that it takes to return to the original control point.

You need a digital voltmeter set to VDC to perform this procedure.

In this task you determine the best I-C setting for a control loop using the response time to a step change.

1. Set up the System 450 analog output for proportional-only control (I-C setting of 0 [zero]), power your controlled system on, operate the system under steady load conditions, and allow the control loop to stabilize at a control point within the proportional band between the selected Setpoint and End Point values.
2. Connect a digital volt-meter across the analog output terminals to measure VDC signal strength changes. Measure and record the signal strength voltage at this (original) stable control point.
3. Change the Setpoint and End Point values to shift (step change) the proportional band 25% away from the original proportional band; the VDC signal rises (or drops) immediately and significantly in response to the proportional band shift. Begin timing the response (to the first step change) at this voltage rise (or drop). The direction of the voltage changes (rise or drop) depends on whether the analog output is set up as a direct-acting or reverse-acting output signal. These instructions refer to the room heating application example shown in Figure 31.

Figure 31: Graph showing temporary proportional band and control point shifts used to measure response time in a heating application

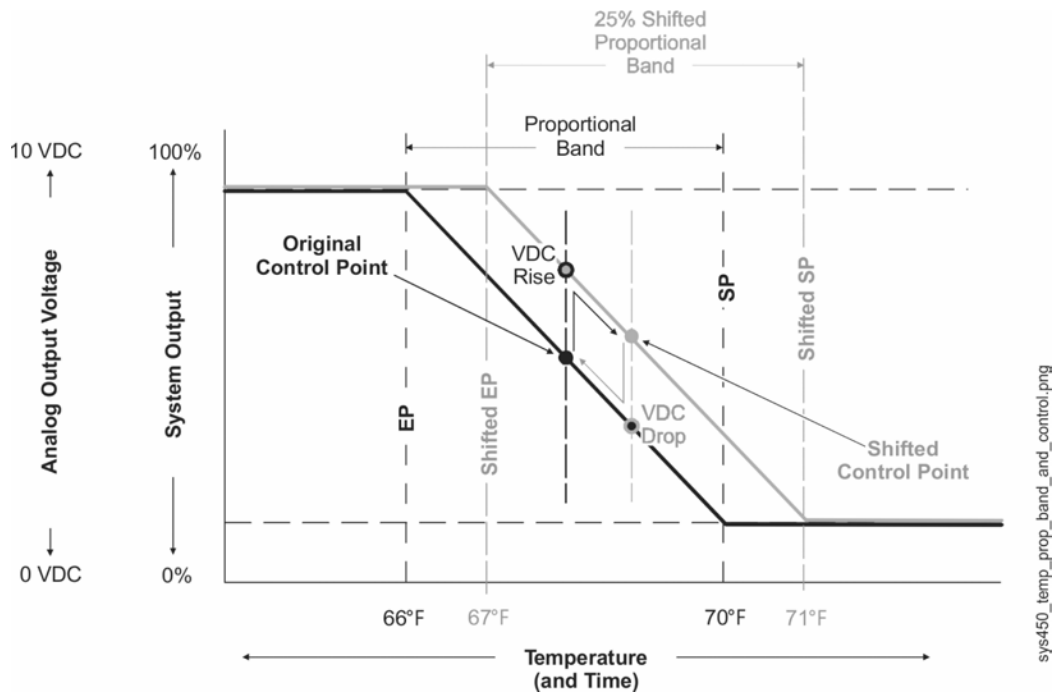

4. Observe the system response and record the time it takes for the measured voltage to drive to and stabilize at the shifted control point in the shifted proportional band. Typically, the shifted control point voltage is slightly higher [or lower] than the original control point voltage.
5. With the controlled system stabilized at the shifted control point, return (second step change) the Setpoint and End Point values back to the original proportional band. The signal VDC drops (or rises) immediately and significantly in response to the proportional band shift back to original. Begin timing the response (to the second step change) at this voltage drop (or rise).
6. Observe the system response and record the time it takes for the measured voltage to drive back to and stabilize at original control point (voltage) in the original proportional band.
 - ⓘ **Note:** In many applications, the response time away from the original control point to the shifted control point is different from the response time of the shifted control point back to the original control point, depending on a variety of factors such as system load and system output. Choose the slower of the two measured response times to determine the I-C setting for your application.
7. Use the slower of the two measured response times and the following table to determine which integration constant (I-C setting) to set on the control and test first.

Table 9: Response times, reset rates, and integration constants

Slowest measured response time for control point shift	Select this integration constant (I-C) value for the analog output	Estimated total reset rate for integration constant
N/A	0	No reset rate
10 to 15 minutes	1	1 hour (3,600 seconds)
6 to 10 minutes	2	30 minutes (1,800 seconds)
3 to 6 minutes	3	15 minutes (900 seconds)
1 to 3 minutes	4	5 minutes (300 seconds)
30 to 60 seconds	5	2 minutes (120 seconds)
10 to 30 seconds	6	1 minute (60 seconds)

8. Set the integration constant to the determined I-C setting. Operate and observe the controlled system at a variety of load conditions to determine if the system is stable at the determined I-C setting over the entire output range of the controlled system.

Troubleshooting System 450 control systems

System 450 control modules display error messages on the LCD when the module detects a sensor, sensor wiring, sensor power, or power supply failure.

Table 10 shows the System 450 error messages that may be displayed, and provides possible causes for the error messages and the solutions for remedying the errors.

Table 10: System 450 control system LCD error messages

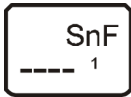
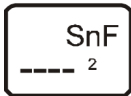
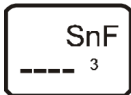
Error screen	Problem or symptom	Possible cause	Solution
  	Sensor failure is detected and < SNF > is displayed (instead of a value). Outputs that reference the failed sensor are operating in the Sensor Failure Modes selected for the Output at setup.	Sensor, sensor wiring, or sensor connections may have failed to open or close.	Check and verify the integrity of sensor wiring and connections. Measure the voltage between the sensor terminal (Sn1, Sn2, or Sn3) and the low-voltage common (C) terminal (with the sensor connected). See Table 11 for the sensor's expected voltage range. If the sensor wiring and sensor connections are good, replace the sensor and recheck the voltage.

Specified voltage ranges for sensors

Table 11 provides the specified operating voltage range for System 450 sensors. To determine if a sensor is operating in the specified range, measure the voltage between the sensor's terminal connections at the System 450 control module (the Sn1, Sn2, or Sn3 terminal and one of the C terminals).

If the voltage is out of the specified range, check the sensor wiring for shorted or open circuits. Repair or replace wiring as needed. If the wiring appears to be in good condition, replace the sensor and retest the voltage and operation.

Table 11: Specified voltage ranges between sensor terminals

Connected sensor	Specified voltage range Measured between a sensor terminal (Sn1, Sn2, or Sn3) and a common terminal (C)
A99B Series and TE-6xxx Series Nickel (1,000 ohms at 70°F) Temperature Sensors	0.49 VDC to 1.43 VDC
HE-69xx Humidity Sensor	0 VDC to 5.0 VDC
DPT2650 Low-Pressure Differential Sensor	0 VDC to 5.0 VDC
P599 Series Pressure Transducer	0.5 VDC to 4.5 VDC

Repair and ordering information

Table 12 provides ordering information for the System 450 Series modules that can be used to build standard control systems. See [System 450 Series Modular Control Systems with Standard Control modules technical specifications](#) for detailed product specifications for the control modules listed in Table 12. Table 14 through Table 23 provide ordering information for the System 450 compatible sensors and transducers. For more information on installing System 450 compatible sensors and transducers, see [Related documentation](#) for additional information on the modules listed in Table 12.

Table 12: System 450 modules and accessories ordering information

Product code	Description
C450CBN-4C	Standard Control Module with LCD, Four-Button Touchpad UI, and Relay Output; provides one relay output (SPDT line-voltage relay) for SPDT control.
C450CCN-4C	Standard Control Module with LCD, Four-Button Touchpad UI, and Relay Output; provides two relay outputs (SPDT line-voltage relays) for SPDT control.
C450CCU-4C	Condensing unit control module with LCD, four-button Touchpad, UI, and two SPDT line-voltage relay outputs. Includes two A99BB-500C temperature sensors with 5 m or 16.38 ft cable length. Sensor temperature range: -40°C to 120°C (-40°F to 250°F); Cable jacket temperature range: -40°C to 100°C (-40°F to 212°F)
C450CPN-4C	Standard Control Module with LCD, Four-Button Touchpad UI, and Analog Output; provides one analog output (0–10 VDC or 4–20 mA self-selecting signal) for proportional control.
C450CQN-4C	Standard Control Module with LCD and Four-Button Touchpad UI, and Analog Output; provides two analog outputs (0–10 VDC or 4–20 mA self-selecting signals) for proportional control.
C450CPW-400C	Hybrid Analog Output Control Module with LCD, Four-Button Touchpad UI, Hybrid Analog Output and Optional High Input Signal Select; provides one hybrid analog output and optional high input signal select primarily used for variable-speed EC motor speed control. Only Analog Output 1 (OUTA1) can be configured as a hybrid analog output and/or use the High Input Signal Selection feature. These features are not available for any of the other outputs in a System 450 control system that uses the C450CPW-400C as the control module.
C450SBN-4C	Relay Output Expansion Module; provides one SPDT line-voltage relay output.
C450SCN-4C	Relay Output Expansion Module; provides two SPDT line-voltage relay outputs.
C450SPN-4C	Analog Output Expansion Module; provides one analog output (0–10 VDC or 4–20 mA self-selecting signal) for proportional control.
C450SQN-4C	Analog Output Expansion Module; provides two analog outputs (0–10 VDC or 4–20 mA self-selecting signals) for proportional control.
C450YNN-1C	Power Module; provides 24 V to System 450 Module Assembly; 120 VAC or 240 VAC supply power input terminals.

Table 13: System 450 mounting accessories

Product code	Description
BKT287-1R	DIN Rail; 0.30 m (12 in.) long
BKT287-2R	DIN Rail; 1 m (39.3 in.) long
BKT287-3R	DIN Rail; 0.61 m (24 in.) long
BKT287-4R	DIN Rail; 0.36 m (14 in.) long
PLT344-1R	DIN Rail End Clamps (2 clamps)
WHA-C450-100C	System 450 module connection extension cable, 100 cm (3.3 ft) long

Table 14: System 450 compatible A99B temperature sensors and accessories ordering information

Product code	Description
A99BA-200C	PTC Silicon Sensor with Shielded Cable; Cable Length 2 m (6.5 ft); Sensor Temperature Range: -40 to 120°C (-40 to 250°F) Cable Jacket Temperature Range: -40 to 100°C (-40 to 212°F)
A99BB-25C	PTC Silicon Sensor with PVC Cable; Cable Length 0.25 m (9.75 in.); Sensor Temperature Range: -40 to 120°C (-40 to 250°F) Cable Jacket Temperature Range: -40 to 100°C (-40 to 212°F)
A99BB-200C	PTC Silicon Sensor with PVC Cable; Cable Length 2 m (6.5 ft); Sensor Temperature Range: -40 to 120°C (-40 to 250°F) Cable Jacket Temperature Range: -40 to 100°C (-40 to 212°F)
A99BB-300C	PTC Silicon Sensor with PVC Cable; Cable Length 3 m (9.75 ft); Sensor Temperature Range: -40 to 120°C (-40 to 250°F) Cable Jacket Temperature Range: -40 to 100°C (-40 to 212°F)
A99BB-500C	PTC Silicon Sensor with PVC Cable; Cable Length 5 m (16.38 ft); Sensor Temperature Range: -40 to 120°C (-40 to 250°F) Cable Jacket Temperature Range: -40 to 100°C (-40 to 212°F)
A99BB-600C	PTC Silicon Sensor with PVC Cable; Cable Length 6 m (19.5 ft); Sensor Temperature Range: -40 to 120°C (-40 to 250°F) Cable Jacket Temperature Range: -40 to 100°C (-40 to 212°F)
A99BC-25C	PTC Silicon Sensor with High Temperature Silicon Cable; Cable Length 0.25 m (9.75 in.) Sensor Temperature Range: -40 to 120°C (-40 to 250°F) Cable Jacket Rated for Full Sensor Temperature Range.
A99BC-300C	PTC Silicon Sensor with High Temperature Silicon Cable; Cable Length 3 m (9.75 ft) Sensor Temperature Range: -40 to 120°C (-40 to 250°F) Cable Jacket Rated for Full Sensor Temperature Range.
A99BC-1500C	PTC Silicon Sensor with High Temperature Silicon Cable; Cable Length 15 m (49 ft) Sensor Temperature Range: -40 to 120°C (-40 to 250°F) Cable Jacket Rated for Full Sensor Temperature Range.
BOX10A-600R	PVC Enclosure for A99 Sensor; Includes Wire Nuts and Conduit Connector (for Outdoor Sensor)
WEL11A-601R	Immersion Well for A99 Sensor Liquid Sensing Applications
A99-CLP-1	Mounting Clip for A99 Temperature Sensor
ADP11A-600R	Conduit Adaptor, 0.5 in. Snap-Fit EMT Conduit Adaptor (box of 10)
TE-6001-1	Duct Mounting Hardware with Handy Box for A99 Sensor
TE-6001-11	Duct Mounting Hardware without Handy Box for A99 Sensor
SHL10A-603R	Sun Shield (for Use with Outside A99 Sensors in Sunny Locations)

① **Note:** Refer to the *A99B Series Temperature Sensors Product/Technical Bulletin (LIT-125186)* for more information.

Table 15: System 450 compatible TE-6000 Series 1,000 Ohms Nickel temperature sensors and accessories ordering information

Product code	Description
TE-6000-1, TE-6000-1x, TE-6000-6	TE6000 Series 1,000 ohms at 21°C (70°F) nickel temperature sensors (only). Only the TE-6000-6 sensor can be used for the entire HI °C and HI °F temperature range. Different sensing element packages are available for various applications. For a complete list of compatible 1,000 ohms nickel sensors, including sensor descriptions, technical specifications, and mounting accessories, refer to the <i>TE-6000 Series Temperature Sensing Elements Product Bulletin (LIT-216288)</i> . (System 450 Sensor Types HI°C and HI°F.)

Table 16: System 450 compatible TE-6300 Series 1,000 Ohms Nickel temperature sensors and accessories ordering information

Product code	Description
TE-631x-x	TE6300 Series 1,000 ohms nickel averaging and 1,000 ohms thin-film nickel temperature sensors (only). For a complete list of compatible 1,000 ohms nickel averaging and thin-film nickel sensors, including sensor descriptions, technical specifications, and accessories, refer to the <i>TE-6300 Series Temperature Sensors Product Bulletin (LIT-216320)</i> . (System 450 Sensor Types HI°C and HI°F.)

Table 17: System 450 compatible TE-68NT-0N00S 1,000 Ohms Nickel temperature sensor ordering information

Product code	Description
TE-68NT-0N00S	TE6800 Series 1,000 ohms at 21°C (70° F) nickel temperature sensor for wall-mount applications. For more information, including sensor description, technical specifications, and mounting accessories, refer to the <i>TE-6800 Series Temperature Sensors Product Bulletin (LIT-12011542)</i> . ⓘ Note: For correct readings, set the temperature sensor to HI°C or HI°F.

Table 18: System 450 compatible HE-69xx type humidity sensors with 100 ohm NTC nickel temperature sensor ordering information

Product code	Description
HE-69S20NP	Duct Mount Humidity Sensor with 1,000 ohm NTC nickel temperature sensor: 10 to 90% RH;-40 to 121°C (-40 to 250° F)

ⓘ **Note:** The HE-69xx0NP sensors require 24 VAC input and must use the 0–5 VDC output. Refer to the *HE-69xx0NP Duct Probe Humidity Element with Temperature Sensor Installation Guide (Part No. 24-11025-00013)* for more information, including technical specifications, and mounting accessories.

Figure 32: HE-69xx



Table 19: System 450 compatible HE6800 Series humidity transmitters with temperature sensor ordering information

Product code	Description
HE-68N2-0N00WS	Wall Mount Humidity Transmitter with Nickel Temperature Sensor: 10 to 90 ±2% RH;0 to 55°C (32 to 131° F)
HE-68N3-0N00WS	Wall Mount Humidity Transmitter with Nickel Temperature Sensor: 10 to 90 ±2% RH;0 to 55°C (32 to 131° F)

ⓘ **Note:** The HE-6800 transmitters require 24 VAC input and must use the 0–5 VDC output. Refer to the *HE-6800 Series Humidity Transmitters with Temperature Sensor Product Bulletin (LIT-12011625)* for more information, including technical specifications and mounting accessories. Note the use of Hi F sensor setting for 1 K ohm Nickel temperature sensors.

Table 20: System 450 compatible low pressure differential transducer ordering information

Product code	Description
DPT2650-0R5D-AB	Low Pressure Differential Transducer: 0 to 0.5 in. W.C. (System 450 Sensor Type: P 0.5)
DPT2650-2R5D-AB	Low Pressure Differential Transducer: 0 to 2.5 in. W.C. (System 450 Sensor Type: P 2.5)
DPT2650-005D-AB	Low Pressure Differential Transducer: 0 to 5.0 in. W.C. (System 450 Sensor Type: P 5)
DPT2650-10D-AB	Low Pressure Differential Transducer: 0 to 10 in. W.C. (System 450 Sensor Type: P 10)

Note:

- Refer to the *Setra Systems Model DPT265 Very Low Differential Pressure Transducer Catalog Page*.
- The DPT265 sensors require 24 VAC input and must use the 0–5 VDC output. Refer to the *Setra Systems Model DPT265 Very Low Differential Pressure Transducer Catalog Page*.

Table 21: System 450 compatible P599 Series transducers with 1/4 in. SAE 45 flare internal thread with depressor (Style 47) ordering information

Product Code	Description	Availability
P599RCPS401C	-1 to 8 bar; order WHA-PKD3 type wire harness separately.	Only available in Europe
P599RCPS402C	-1 to 15 bar; order WHA-PKD3 type wire harness separately.	Only available in Europe
P599RCPS402C	0 to 30 bar; order WHA-PKD3 type wire harness separately.	Only available in Europe
P599RCPS405C	0 to 50 bar; order WHA-PKD3 type wire harness separately.	Only available in Europe
P599RCPS100C	-10 to 100 psis (sealed for wet and freeze/thaw applications); order WHA-PKD3 type wire harness separately.	Only available in North America
P599RCPS100K	-10 to 100 psis (sealed for wet and freeze/thaw applications); WHA-PKD3-200C wire harness included.	Only available in North America
P599RCPS102C	0 to 200 psis (sealed for wet and freeze/thaw applications); order WHA-PKD3 type wire harness separately.	Only available in North America
P599RCPS102K	0 to 200 psis (sealed for wet and freeze/thaw applications); WHA-PKD3-200C wire harness included.	Only available in North America
P599RCPS101C	0 to 100 psig; order WHA-PKD3 type wire harness separately.	Only available in North America
P599RCPS101K	0 to 100 psig; WHA-PKD3-200C wire harness included.	Only available in North America
P599RCPS105C	0 to 500 psig; order WHA-PKD3 type wire harness separately.	Only available in North America
P599RCPS105K	0 to 500 psig; WHA-PKD3-200C wire harness included.	Only available in North America
P599RCPS107C	0 to 750 psig; order WHA-PKD3 type wire harness separately.	Only available in North America
P599RCPS107K	0 to 750 psig; WHA-PKD3-200C wire harness included.	Only available in North America

- Note:** The P599 sensors must be powered with the +5 VDC and C terminals and the output is 0.5 to 4.5 VDC. Refer to the *P599 Series Electronic Pressure Transducers Product/Technical Bulletin (LIT-12012446)*.

Table 22: System 450 compatible P599 Series transducers with 1/8 in. 27 NPT external thread (Style 49) ordering information

Product code	Description
P599RAPS100C	-10 to 100 psis (sealed for wet and freeze/thaw applications); order a WHA-PKD3 type wire harness separately.
P599RAPS100K	-10 to 100 psis (sealed for wet and freeze/thaw applications); WHA-PKD3-200C wire harness included.
P599RAPS101C	0 to 100 psig; order a WHA-PKD3 type wire harness separately.
P599RAPS101K	0 to 100 psig; WHA-PKD3-200C wire harness included.

Table 22: System 450 compatible P599 Series transducers with 1/8 in. 27 NPT external thread (Style 49) ordering information

Product code	Description
P599RAPS102C	0 to 200 psig; order a WHA-PKD3 type wire harness separately.
P599RAPS105C	0 to 500 psig; order WHA-PKD3 type wire harness separately.
P599RAPS105K	0 to 500 psig; WHA-PKD3-200C wire harness included.
P599RAPS107C	0 to 750 psig; order WHA-PKD3 type wire harness separately.
P599RAPS107K	0 to 750 psig; WHA-PKD3-200C wire harness included.

① **Note:** The P599 sensors must be powered with the +5 VDC and C terminals and the output is 0.5 to 4.5 VDC. Refer to the *P599 Series Electronic Pressure Transducers Product/Technical Bulletin (LIT-12012446)*.

Table 23: WHA-PKD3 Wire Harnesses ordering information

Product code	Description
WHA-PKD3-200C	Plug and 3-Wire Harness for P599 Electronic Pressure Transducers: 2.0 m (6.5 ft) cable
WHA-PKD3-400C	Plug and 3-Wire Harness for P599 Electronic Pressure Transducers: 4.0 m (13 ft) cable
WHA-PKD3-600C	Plug and 3-Wire Harness for P599 Electronic Pressure Transducers: 6.0 m (19.6 ft) cable

① **Note:** Refer to the *P599 Series Electronic Pressure Transducers Product/Technical Bulletin (LIT-12012446)*.

Related documentation

Table 24 provides references to System 450 related documentation, including sensor installation instructions.

Table 24: Related documentation

For information about	See document	LIT or Part Number
System 450 Series Features, Benefits, Models, and Technical Specifications	<i>System 450 Series Modular Controls Product Bulletin</i>	LIT-12011458
System 450 Series Features, Benefits, Models, and Technical Specifications	<i>System 450 Series Modular Controls Catalog Page</i>	LIT-1900549
Installing, Wiring, and Setting up System 450 Control Modules with Relay Output	<i>System 450 Series Control Modules with Relay Outputs Installation Instructions</i>	Part No. 24-7664-3025
Installing, Wiring, and Setting up System 450 Control Modules with Analog Output	<i>System 450 Series Control Modules with Analog Outputs Installation Instructions</i>	Part No. 24-7664-3191
Installing, Wiring, and Setting up System 450 Control Modules with Hybrid Analog Output and High Input Signal Selection	<i>System 450 Series Control Module with Hybrid Analog Output and High Input Signal Selection Installation Instructions</i>	Part No. 24-7664-2802
Installing and Wiring System 450 Expansion Modules with Relay Output	<i>System 450 Series Expansion Modules with Relay Outputs Installation Instructions</i>	Part No. 24-7664-2861
Installing and Wiring System 450 Expansion Modules with Analog Output	<i>System 450 Series Expansion Modules with Analog Outputs Installation Instructions</i>	Part No. 24-7664-2799
Installing and Wiring the System 450 Power Module	<i>System 450 Series Power Module Installation Instructions</i>	Part No. 24-7664-2691
Installing and Wiring the A99 Series Temperature Sensors	<i>A99B Series Temperature Sensors Product/Technical Bulletin</i>	LIT-125186, Part No. 24-7664-1636
Installing and Wiring the TE-6000 Series Temperature Sensing Elements	<i>TE-6000 Series Temperature Sensing Elements Installation Instructions</i>	Part No. 24-4034-26
Installing and Wiring the TE-6300P Series Temperature Sensors	<i>TE-6300P Series Temperature Sensors Installation Instructions</i>	Part No. 24-4034-107
Installing and Wiring the TE-6300M Series Well Insertion Temperature Sensors	<i>TE-6300M Series Well Insertion Temperature Sensors Installation Instructions</i>	Part No. 24-4034-182

Table 24: Related documentation

For information about	See document	LIT or Part Number
Installing and Wiring the TE-6300P Series Outdoor Air Temperature Sensors	<i>TE-6300P Series Outdoor Air Temperature Sensors Installation Instructions</i>	Part No. 24-4034-190
Installing and Wiring the TE-6300V Series Flange Mount Duct Averaging Temperature Sensors	<i>TE-6300V Series Flange Mount Duct Averaging Temperature Sensors Installation Instructions</i>	Part No. 24-4034-220
Installing and Wiring the TE-6300P Series Wall Mount Temperature Sensors	<i>TE-6300P Series Wall Mount Temperature Sensors Installation Instructions</i>	Part No. 24-4034-204
Installing and Wiring the TE-6300M Series Duct Averaging Temperature Sensors	<i>TE-6300M Series Duct Averaging Temperature Sensors Installation Instructions</i>	Part No. 24-4034-174
Installing and Wiring the TE-6300F Series Flush Mount Sensors	<i>TE-6300F Series Flush Mount Sensors Installation Instructions</i>	Part No. 24-4034-255
Installing and Wiring the TE-6300A Series Adjustable Length Duct Probe Temperature Sensors	<i>TE-6300A Series Adjustable Length Duct Probe Temperature Sensors Installation Instructions</i>	Part No. 24-4034-247
Installing and Wiring the TE-6300V Series Flange Mount Duct Probe Temperature Sensors	<i>TE-6300V Series Flange Mount Duct Probe Temperature Sensors Installation Instructions</i>	Part No. 24-4034-212
Installing and Wiring the TE-6300M Series Duct Probe Temperature Sensors	<i>TE-6300M Series Duct Probe Temperature Sensors Installation Instructions</i>	Part No. 24-4034-166
Installing and Wiring the TE-6800 Series Temperature Sensors	<i>TE-6800 Series Temperature Sensors Installation Instructions</i>	Part No. 24-10409-1
Installing and Wiring the P599 Series Electronic Pressure Transducers	<i>P599 Series Electronic Pressure Transducers Product/Technical Bulletin</i>	LIT-12012446, Part No. 24-7664-3264
Installing and Wiring the HE-6800 Humidity Sensors and Humidity with Temperature Sensors	<i>HE-6800 Series Humidity Transmitters with Temperature Sensor Installation Guide</i>	Part No. 24-10409-28
Installing and Wiring the HE-6900 Humidity Sensors and Humidity with Temperature Sensors	<i>HE-69xxONP Duct Probe Humidity Element with Temperature Sensor Installation Guide</i>	Part No. 24-11025-00013
Installing and Wiring Setra Systems Model 265 Differential Pressure Transducers	<i>Setra Systems Model 265 Differential Pressure Transducer Installation Guide</i>	Search Johnson Controls documentation for Setra System Model 265.

System 450 Series Modular Control Systems with Standard Control modules technical specifications

Table 25: C450CPN-4 and C450CQN-4 control modules with analog output technical specifications

Specification	Description
Product	C450CPN-4 and C450CQN-4: System 450 Control Module models are sensing controls and operating controls with LCD, four-button touchpad, and SPDT analog output C450CPN-4: Control Module with one analog output C450CQN-4: Control Module with two analog outputs
Power consumption	C450CPN-4: 1.3 VA maximum using 0-10 V out; 1.5 VA maximum using 4-20 mA out C450CQN-4: 2.0 VA maximum using 0-10 V out; 2.4 VA maximum using 4-20 mA out
Supply power	Internal Supply Power: C450YNN-1C Power Supply Module External Supply Power: 24 VAC (20-30 VAC) Safety Extra-Low Voltage (SELV) (Europe), Class 2 (North America), 50/60 Hz, 10 VA minimum Note: A System 450 control module or module assembly can use an internal or an external supply power source, but must not be connected to both simultaneously.
Ambient operating conditions	Temperature: -40 to 66°C (-40 to 150°F) when using 0-10 VDC outputs; -40 to 40°C (-40 to 104°F) when using 4-20 mA outputs Humidity: Up to 95% RH non-condensing; Maximum Dew Point 29°C (85°F)

Table 25: C450CPN-4 and C450CQN-4 control modules with analog output technical specifications

Specification	Description
Ambient shipping and storage conditions	Temperature: -40 to 80°C (-40 to 176°F) Humidity: Up to 95% RH non-condensing; Maximum Dew Point 29°C (85°F)
Input signal	0-5 VDC for humidity sensors and static pressure transducers 0.5-4.5 VDC for ratiometric pressure transducers 1,035 ohms at 25°C (77°F) for A99 PTC temperature sensors 1,000 ohms at 21.1°C (70°F) for TE-6xxx Nickel temperature sensors
Analog output	Voltage Mode (0-10 VDC): 10 VDC maximum output voltage 10 mA maximum output current Requires an external load of 1,000 ohms or more The AO operates in Voltage Mode when connected to devices with impedance greater than 1,000 ohms. Devices that fall below 1,000 ohms may not operate as intended with Voltage Mode applications.
	Current Mode (4-20 mA): Requires an external load between 0-300 ohms The AO operates in Current Mode when connected to devices with impedance less than 300 ohms. Devices that rise above 300 ohms may not operate as intended with Current Mode applications.
Analog input accuracy	Resolution: 14 bit
Enclosure	Type 1, IP20 High-Impact Thermoplastic
Dimensions (H x W x D)	127 x 61 x 61 mm (5.00 x 2.38 x 2.38 in.)
Weight	C450CPN-4: 195 g (0.43 lb) C450CQN-4: 195 g (0.43 lb)
Compliance	United States: UL 60730-1, File E27734; FCC Compliant to CFR47, Part 15, Subpart B, Class B limits
	Canada: cULus Listed; CAN/CSA-E60730-1, File E27734; Industry Canada (IC) Compliant to Canadian ICES-003, Class B limits
	Europe: CE Mark - Johnson Controls declares that this product is in compliance with the essential requirements and other relevant provisions of the EMC Directive.
	Australia and New Zealand: RCM mark, Australia/NZ emissions compliant

Table 26: C450CPW-400C control module with hybrid analog output technical specifications

Specification	Description
Product	C450CPW-400C System 450 control module is a sensing control and operating control with LCD, four-button touchpad, and analog output with pulse-width modulation capability.
Power consumption	C450CPW-400C: 1.3 VA maximum using 0-10 V out; 1.5 VA maximum using 4-20 mA out
Supply power	Internal Supply Power: C450YNN-1C Power Supply Module External Supply Power: 24 VAC (20-30 VAC) Safety Extra-Low Voltage (SELV) (Europe), Class 2 (North America), 50/60 Hz, 10 VA minimum  Note: A System 450 control module or module assembly can use an internal or an external supply power source, but must not be connected to both simultaneously.
Ambient operating conditions	Temperature: -40 to 66°C (-40 to 150°F) when using 0-10 VDC outputs; -40 to 40°C (-40 to 104°F) when using 4-20 mA outputs Humidity: Up to 95% RH non-condensing; Maximum Dew Point 29°C (85°F)
Ambient shipping and storage conditions	Temperature: -40 to 80°C (-40 to 176°F) Humidity: Up to 95% RH non-condensing; Maximum Dew Point 29°C (85°F)
Input signal	0-5 VDC for humidity sensors and static pressure transducers 0.5-4.5 VDC for ratiometric pressure transducers 1,035 ohms at 25°C (77°F) for A99 PTC temperature sensors 1,000 ohms at 21.1°C (70°F) for TE-6xxx Nickel temperature sensors

Table 26: C450CPW-400C control module with hybrid analog output technical specifications

Specification	Description
Analog output	Voltage Mode (0–10 VDC): 10 VDC maximum output voltage 10 mA maximum output current Requires an external load of 1,000 ohms or more The AO operates in Voltage Mode when connected to devices with impedance greater than 1,000 ohms. Devices that fall below 1,000 ohms may not operate as intended with Voltage Mode applications.
	Current Mode (4–20 mA): Requires an external load between 0–300 ohms The AO operates in Current Mode when connected to devices with impedance less than 300 ohms. Devices that rise above 300 ohms may not operate as intended with Current Mode applications.
Analog input accuracy	Resolution: 14 bit
Enclosure	Type 1, IP20 High-Impact Thermoplastic
Dimensions (H x W x D)	127 x 61 x 61 mm (5.00 x 2.38 x 2.38 in.)
Weight	C450CPW-400C: 195 g (0.43 lb)
Compliance	United States: UL 60730-1, File E27734; FCC Compliant to CFR47, Part 15, Subpart B, Class B
	Canada: cULus Listed; CAN/CSA-E60730-1, File E27734; Industry Canada (IC) Compliant to Canadian ICES-003, Class B limits
	Europe: CE Mark – Johnson Controls declares that this product is in compliance with the essential requirements and other relevant provisions of the EMC Directive.
	Australia and New Zealand: RCM mark, Australia/NZ emissions compliant

Table 27: C450CBN-4 and C450CCN-4 control modules with relay output technical specifications

Specification	Description
Product	C450CBN-4 and C450CCN-4: System 450 Control Module models are sensing controls and operating controls with LCD, four-button touchpad, and SPDT relay output C450CBN-4: Control Module with one SPDT output relay C450CCN-4: Control Module with two SPDT output relays
Power consumption	C450CBN-4: 0.9 VA maximum C450CCN-4: 1.3 VA maximum
Supply power	Internal Supply Power: C450YNN-1C Power Supply Module External Supply Power: 24 VAC (20–30 VAC) Safety Extra-Low Voltage (SELV) (Europe), Class 2 (North America), 50/60 Hz, 10 VA minimum  Note: A System 450 control module or module assembly can use an internal or an external supply power source, but must not be connected to both simultaneously.
Ambient operating conditions	Temperature: -40 to 66°C (-40 to 150 ° F) Humidity: Up to 95% RH non-condensing; Maximum Dew Point 29°C (85°F)
Ambient shipping and storage conditions	Temperature: -40 to 80°C (-40 to 176°F) Humidity: Up to 95% RH non-condensing; Maximum Dew Point 29°C (85°F)
Input signal	0–5 VDC for humidity sensors and static pressure transducers 0.5–4.5 VDC for ratiometric pressure transducers 1,035 ohms at 25°C (77°F) for A99 PTC temperature sensors 1,000 ohms at 21.1°C (70°F) for TE-6xxx Nickel temperature sensors
Output relay contacts	General: 1/2 HP at 120/240 VAC, SPDT Specific: AC Motor Ratings 120 VAC <ul style="list-style-type: none"> • AC Full-load Amperes: 9.8 A • Locked-Rotor Amperes: 58.8 A AC Motor Ratings 208/240 VAC <ul style="list-style-type: none"> • AC Full-load Amperes: 4.9 A • Locked-Rotor Amperes: 29.4 A 10 Amperes AC Non-inductive at 24/240 VAC Pilot Duty: 125 VA at 24/240 VAC
Analog input accuracy	Resolution: 14 bit
Enclosure	Type 1, IP20 High-Impact Thermoplastic

Table 27: C450CBN-4 and C450CCN-4 control modules with relay output technical specifications

Specification	Description
Dimensions (H x W x D)	127 x 61 x 61 mm (5.00 x 2.38 x 2.38 in.)
Weight	C450CBN-4: 209 g (0.46 lb) C450CCN-4: 222 g (0.49 lb)
Compliance	United States: UL 60730-1, File E27734; FCC Compliant to CFR47, Part 15, Subpart B, Class B
	Canada: cULus Listed; CAN/CSA-E60730-1, File E27734; Industry Canada (IC) Compliant to Canadian ICES-003, Class B limits
CE	Europe: CE Mark – Johnson Controls declares that this product is in compliance with the essential requirements and other relevant provisions of the EMC Directive.
	Australia and New Zealand: RCM mark, Australia/NZ emissions compliant

Table 28: C450SPN-4C and C450SQN-4C expansion modules with analog output technical specifications

Specification	Description
Product	C450SPN-4C: System 450 Expansion Module with one Analog Output C450SQN-4C: System 450 Expansion Module with two Analog Outputs
Power consumption	C450SPN-4C: 1.1 VA max using 0–10 V out; 1.3 VA maximum using 4–20 mA out C450SQN-4C: 1.8 VA max using 0–10 V out; 2.2 VA maximum using 4–20 mA out
Supply power	Internal Supply Power: C450YNN-1C Power Supply Module External Supply Power: 24 VAC (20–30 VAC) Safety Extra-Low Voltage (SELV) (Europe), Class 2 (North America), 50/60 Hz, 10 VA minimum i Note: A System 450 control module or module assembly can use an internal or an external supply power source, but must not be connected to both simultaneously.
Ambient operating conditions	Temperature: -40 to 66°C (-40 to 150°F) when using 0–10 VDC outputs; -40 to 40 ° C (-40 to 104°F) when using 4–20 mA outputs Humidity: Up to 95% RH non-condensing; Maximum Dew Point 29°C (85°F)
Ambient shipping and storage conditions	Temperature: -40 to 80°C (-40 to 176°F) Humidity: Up to 95% RH non-condensing; Maximum Dew Point 29°C (85°F)
Analog output	Voltage Mode (0–10 VDC): 10 VDC maximum output voltage 10 mA maximum output current Requires an external load of 1,000 ohms or more The AO operates in Voltage Mode when connected to devices with impedance greater than 1,000 ohms. Devices that fall below 1,000 ohms may not operate as intended with Voltage Mode applications. Current Mode (4–20 mA): Requires an external load between 0–300 ohms The AO operates in Current Mode when connected to devices with impedance less than 300 ohms. Devices that rise above 300 ohms may not operate as intended with Current Mode applications.
Enclosure	Type 1, IP20 High-Impact Thermoplastic
Dimensions (H x W x D)	127 x 61 x 61 mm (5.00 x 2.38 x 2.38 in.)
Weight	C450SPN-4C: 150 g (0.33 lb) C450SQN-4C: 150 g (0.33 lb)
Compliance	United States: UL 60730-1, File E27734; FCC Compliant to CFR47, Part 15, Subpart B, Class B
	Canada: cULus Listed; CAN/CSA-E60730-1, File E27734; Industry Canada (IC) Compliant to Canadian ICES-003, Class B limits
CE	Europe: CE Mark – Johnson Controls declares that this product is in compliance with the essential requirements and other relevant provisions of the EMC Directive.
	Australia and New Zealand: RCM mark, Australia/NZ emissions compliant

Table 29: C450SBN-4C and C450SCN-4C expansion modules with relay output technical specifications



Specification	Description
Product	C450SBN-4C: System 450 Expansion Module with one SPDT output relay C450SCN-4C: System 450 Expansion Module with two SPDT output relays
Power consumption	C450SBN-4C: 0.8 VA maximum C450SCN-4C: 1.2 VA maximum
Supply power	Internal Supply Power: C450YNN-1C Power Supply Module External Supply Power: 24 VAC (20–30 VAC) Safety Extra-Low Voltage (SELV) (Europe), Class 2 (North America), 50/60 Hz, 10 VA minimum  Note: A System 450 control module or module assembly can use an internal or an external supply power source, but must not be connected to both simultaneously.
Ambient operating conditions	Temperature: -40 to 66°C (-40 to 150°F) Humidity: Up to 95% RH non-condensing; Maximum Dew Point 29°C (85°F)
Ambient shipping and storage conditions	Temperature: -40 to 80°C (-40 to 176°F) Humidity: Up to 95% RH non-condensing; Maximum Dew Point 29°C (85°F)
Output relay contacts	General: 1/2 HP at 120/240 VAC, SPDT Specific: AC Motor Ratings 120 VAC <ul style="list-style-type: none"> • AC Full-Load Amperes: 9.8 A • AC Locked-Rotor Amperes: 58.8 A AC Motor Ratings 208/240 VAC <ul style="list-style-type: none"> • AC Full-Load Amperes: 4.9 A • AC Locked-Rotor Amperes: 29.4 A 10 Amperes AC Non-inductive at 24/240 VAC Pilot Duty: 125 VA at 24/240 VAC
Control construction	Independently mounted control, surface mounted with Lexan® 950 enclosure suitable for DIN rail mounting or direct mounting to a hard, even surface.
Dimensions (H x W x D)	127 x 61 x 61 mm (5.00 x 2.38 x 2.38 in.)
Weight	C450SBN-4C: 172 g (0.38 lb) C450SCN-4C: 186 g (0.41 lb)
Compliance	United States: UL 60730-1, File E27734; FCC Compliant to CFR47, Part 15, Subpart B, Class B
	Canada: cULus Listed; CAN/CSA-E60730-1, File E27734; Industry Canada (IC) Compliant to Canadian ICES-003, Class B limits
	Europe: CE Mark – Johnson Controls declares that this product is in compliance with the essential requirements and other relevant provisions of the EMC Directive.
	Australia and New Zealand: RCM mark, Australia/NZ emissions compliant

Table 30: C450YNN-1C power supply module technical specifications

Specification	Description
Product	C450YNN-1C: System 450 Power Supply Module; 120 or 240 VAC stepdown to 24 VAC Class 2 (North America) or SELV (Europe)
Supply power	110/120 VAC or 220/240 VAC at 50/60 Hz (100 mA maximum)
Secondary power	24 VAC, 10 VA
Ambient operating conditions	Temperature: -40 to 66°C (-40 to 150°F) Humidity: Up to 95% RH non-condensing; Maximum Dew Point 29°C (85°F)
Ambient shipping and storage Conditions	Temperature: -40 to 80°C (-40 to 176°F) Humidity: Up to 95% RH non-condensing; Maximum Dew Point 29°C (85°F)
Enclosure	Type 1, IP20 High-Impact Thermoplastic
Dimensions (H x W x D)	127 x 61 x 61 mm (5.00 x 2.38 x 2.38 in.)
Weight	C450YNN-1C: 390 gm (0.86 lb)
Compliance	United States: UL 60730-1, File E27734; FCC Compliant to CFR47, Part 15, Subpart B, Class B

Table 30: C450YNN-1C power supply module technical specifications

Specification	Description
	Canada: cULus Listed; CAN/CSA-E60730-1, File E27734; Industry Canada (IC) Compliant to Canadian ICES-003, Class B limits
CE	Europe: CE Mark – Johnson Controls declares that this product is in compliance with the essential requirements and other relevant provisions of the EMC Directive and the Low Voltage Directive.
	Australia and New Zealand: RCM mark, Australia/NZ emissions compliant

The performance specifications are nominal and conform to acceptable industry standards. For application at conditions beyond these specifications, Johnson Controls shall not be liable for damages resulting from misapplication or misuse of its products.

North American emissions compliance

United States

This equipment has been tested and found to comply with the limits for a Class B digital device, pursuant to Part 15 of the FCC Rules. These limits are designed to provide reasonable protection against harmful interference in a residential installation. This equipment generates, uses and can radiate radio frequency energy and, if not installed and used in accordance with the instructions, may cause harmful interference to radio communications. However, there is no guarantee that interference will not occur in a particular installation. If this equipment does cause harmful interference to radio or television reception, which can be determined by turning the equipment off and on, the user is encouraged to try to correct the interference by one or more of the following measures:

- Reorient or relocate the receiving antenna.
- Increase the separation between the equipment and receiver.
- Connect the equipment into an outlet on a circuit different from that to which the receiver is connected.
- Consult the dealer or an experienced radio/TV technician for help.

Warning (Part 15.21)

Changes or modifications not expressly approved by the party responsible for compliance could void the user's authority to operate the equipment.

Canada

This Class (B) digital apparatus meets all the requirements of the Canadian Interference-Causing Equipment Regulations.

Cet appareil numérique de la Classe (B) respecte toutes les exigences du Règlement sur le matériel brouilleur du Canada.

Industry Canada Statement(s)

This device complies with Industry Canada licence-exempt RSS standard(s). Operation is subject to the following two conditions:

1. This device may not cause interference, and
2. This device must accept any interference, including interference that may cause undesired operation of the device.

Le présent appareil est conforme aux CNR d'Industrie Canada applicables aux appareils radio exempts de licence. L'exploitation est autorisée aux deux conditions suivantes :

1. L'appareil ne doit pas produire de brouillage, et
2. L'utilisateur de l'appareil doit accepter tout brouillage radioélectrique subi, même si le brouillage est susceptible d'en compromettre le fonctionnement.

Glossary of terms

°C

Degrees Celsius (°C) appears in the Main (sensor status) screens, along with the current sensed temperature value, when a Celsius temperature sensor is set up in your control system. °C also designates a Sensor Type that is available when you set up the sensors in the Sensor Setup screens. See [Accessing and Navigating the User Interface](#) and [System 450 Compatible Sensors and Transducers](#) for more information.

°F

Degrees Fahrenheit (°F) appears in the Main (sensor status) screens, along with the current sensed temperature value, when a Fahrenheit temperature sensor is set up in your control system. °F also designates a Sensor Type that is available when you set up the sensors in the Sensor Setup screens. See [Accessing and Navigating the User Interface](#) and [System 450 Compatible Sensors and Transducers](#) for more information.

Analog Output

System 450 provides self-selecting 0 to 10 VDC signal or 4 to 20 mA signal analog outputs. The analog outputs can be set up to provide a wide variety of direct and reverse acting proportional control applications, including multi-stage control and proportional plus integral control. Analog outputs are identified in the System 450 UI as OUTA in the Output Setup Start screens and with a percent signal strength and control ramp icon in the System Status screens. See [Analog Outputs](#), [Analog Output Setup](#), and [Viewing the System Status Screens](#) for more information.

bAR

bAR appears in the Main (sensor status) screens along with the current sensed pressure value, when your control system uses one or more pressure transducers with P 8, P 15, P 30, or P 50 Sensor Types. Bar is an SI (International System) unit of measurement for the pressure value displayed in the Main screens. One bar is equal to approximately one atmosphere of pressure, 14.5 psi, and 100 kPa. See [System 450 Sensors and Transducers for Standard Control Modules](#) for more information.

bin

The Binary Input (bin) sensor provides relay output control using an external (user-supplied) binary input or set of dry contacts to control the relay output state (On or Off) based on the binary input state (closed or open). A binary input can be connected to the Sn1, Sn2, or Sn3 terminals and a C terminal on the control module. See [Binary Input Control for Relay Outputs](#) for more information.

bKLT

The backlight brightness level feature allows you to adjust the LCD backlight intensity. bKLL OFF = the backlight is off. bKLL 10 = the brightest backlight setting and the system default. The selected backlight brightness level is applied to the LCD during normal operation. When you enter the programming menus to set up the control or press any key, the LCD automatically goes to the brightest level. If no key is pressed for 30 seconds, the main screen is displayed and the backlight setting reverts to the selected brightness level.

bNd

In the Output Signal Deadband (bNd^x) screen in the Analog Output Setup screens, select the output deadband value (as a percentage of the total output signal range). You can select a value between 0 and 50 (percent).

Control Module

The primary module in a System 450 control system, and sometimes the only module in stand-alone control systems. Each System 450 control system has only one control module, which contains the control system processor, firmware, memory, and LCD. The control module receives the input signals from the system sensors, and it monitors and controls all of the system outputs, including the expansion module outputs. There are four types of System 450 control modules: standard control modules, reset control modules, hybrid analog output control modules, and communications control modules. See [Control Module and User Interface](#) and [Repair and Ordering Information](#) for more information.

dEP^x

In the Differential End Point (dEP^x) screen in the Analog Output Setup screens, select the differential value that analog output number x is driving the controlled loop or process away from. The dEP value, along with Differential Setpoint (dSP) value, establishes the output's proportional control band. The dEP screen appears in the Analog Output Setup screens after you set up and select the Differential Sensor (Sn-d) for the output reference. See [Differential Control](#) for more information.

Differential Control

The Differential Control feature is used to monitor and maintain a selected difference in a condition (temperature, pressure, or humidity) between two sensor points within a system, process, or space. See [Differential Control](#) for more information.

Direct Acting

With Direct Acting proportional control, an increase in the sensor signal results in a proportional increase of the output signal generated to the controlled equipment and vice versa. See [Direct and Reverse Control Actions for Analog Outputs](#) for more information.

dSP^x

In the Differential Setpoint (dSP^x) screen in the Analog Output Setup screens, select the target differential value that analog output number x is driving the controlled loop towards. The dSP value, along with Differential End Point (dEP) establishes the output's proportional control band. The dSP screen appears in the Analog Output Setup screens after you select the Differential Sensor (Sn-d) for the output reference. See [Differential Control](#) for more information.

EC Motor

Brushless, low-radio-frequency emitting motors, available in variable-speed (full-range modulating) motor models, multiple-speed (selectable fixed-speeds) motor models, and models capable of being set up as either variable or multiple speed motors. Electronically Commutated (EC) motors are quiet, clean, energy-efficient motors that operate efficiently at low speeds. PENN by Johnson Control EC motors provide a wide range of models for both indoor and outdoor HVAC/R applications. The System 450 control module with hybrid analog output (C450DPW-100) is designed to enhance and optimize EC motor operation at very low speeds. See [Sensor Failure Mode, Hybrid Analog and High Input Signal Selection Control System Example](#), and [Setting up a Pulse Region Hybrid Analog Output](#) for more information.

EP^x

In the End Point Selection (EP^x) screen in the Analog Output Setup screens, select the condition value that analog output number x is driving the control loop away from and towards the Setpoint (SP) value. The EP and SP values define the proportional band that the analog output is intended to control the condition within. See [Direct and Reverse Control Actions for Analog Outputs](#) for more information.

Expansion Modules

Provide additional relay or analog outputs to your control system. Expansion module models are available with one or two relay outputs, and one or two analog outputs. All of the outputs in a control system, including the Expansion module outputs are set up in the control module UI. System 450 control systems can control up to 10 outputs, which can be any combination of relay or analog outputs. See [Expansion Modules, Module Assemblies, and Outputs](#) and [Repair and Ordering Information](#) for more information.

Functional Sensor

In addition to the wide variety of System 450 compatible hard-wired temperature, pressure, and humidity sensors available, the System 450 firmware also enables several functional sensors based on the input from one or more of the hard-wired sensors in your control system. Functional sensors include: the Reset Setpoint sensor (rES), which enables reset control, setback control, and run-time balancing; the Differential Control sensor (Sn-d), which enables the Differential Control feature; and the High Input Signal Selection functional sensors (HI-2 and HI-3), which enable the High Input Signal Selection feature. When you select a functional sensor for an output, the output is controlled according to values sensed at multiple sensors and the control logic/calculation designed into the functional sensor. See [System 450 Functional Sensors](#) for more information.

Hg

Hg appears in the Main (sensor status) screens along with the current sensed pressure value, when your control system uses one or more pressure transducers with P 110 Sensor Types. Hg is an abbreviation of the unit of measurement inHg, which is used to measure negative pressure values (below 0 psi). P 110 Sensor Type is capable of monitoring and displaying negative pressure values. Outputs that reference P 110 sensors requires a unique setup calculation and the negative pressure values are displayed differently in the P 110 setup and status screens. See [System 450 Sensors and Transducers for Standard Control Modules](#) and [Setting Up Outputs That Reference a P 110 Sensor](#) for more information.

HI-2

A functional High Input Signal Selection Sensor that references two hard-wired sensors of the same Sensor Type. When you set up the hard-wired sensors Sn-1 and Sn-2 as the same Sensor Type, functional sensor HI-2 is available for selection when you set up the control system outputs. Outputs that are set up to reference HI-2 use the higher of the two condition values (sensed at Sn-1 and Sn-2) to control the output. High Input Signal selection is available on standard control modules with firmware Version 2.00 or later, hybrid analog output control modules, and communication control modules, but is not available on reset control modules. See [High Input Signal Selection](#) for more information.

HI-3

A functional High Input Signal Selection Sensor that references three hard-wired sensors of the same Sensor Type. When you set up the hard-wired sensors Sn-1, Sn-2, and Sn-3 as the same Sensor Type, functional sensor HI-3 is available for selection when you set up the control system outputs. Outputs that are set up to reference HI-3 use the highest of the three condition values (sensed at Sn-1, Sn-2, and Sn-3) to control the output. High Input Signal selection is available

on standard control modules with firmware Version 2.00 or later, hybrid analog output control modules, and communication control modules, but is not available on reset control modules. See [High Input Signal Selection](#) for more information.

High Input Signal Selection

Functional High Input Signal Selection sensors (HI-2, HI-3) enable an output to reference two or three hard-wired sensors of the same Sensor Type and control the output by responding to the input sensor that is sensing the highest value (temperature, pressure, or humidity) from the two or three sensed values. The High Input Signal Selection feature is on standard control modules with firmware Version 2.00 or later, on the hybrid analog control module, and also on the communication control modules. See [High Input Signal Selection](#) for more information.

I-C^x

In the Integration Constant Selection (I-C^x) screen in the Analog Output Setup screens, select the I-C value for analog output x in your control system. There are seven integration constants values to select from (0 through 6). In most applications, the default integration value 0 (no integration constant, proportional-only control) is the recommended selection. See [Proportional Plus Integral Control and Integration Constants](#) and [Determining the Integration Constant for an Analog Output](#) for more information.

Integration Constant

A time-integral variable, which is applied to the proportional control only analog output to provide Proportional plus Integral (P-I) control on the output. The integration constant determines the rate at which the control readjusts the output signal to drive the process to setpoint. In well-balanced control applications with predictable loads and properly sized equipment, P-I control provides tighter control to setpoint and a faster response to system load changes than proportional-only control. See [Proportional Plus Integral Control and Integration Constants](#) and [Determining the Integration Constant for an Analog Output](#) for more information.

inHg

Represents Inches of Mercury (see the Hg term and definition).

INWC

INWC and the sensed pressure value appears in the Main (sensor status) screens on control systems using a sensor with a Sensor Type of P 0.5, P 2.5, P 5, or P 10. INWC represents Inches Water Column (in.W.C.), which is a unit of measurement for measuring very low pressures such as building and duct static pressures and pressure differentials. See [System 450 Sensors and Transducers for Standard Control Modules](#) for more information.

LEV¹

In the Pulse Output Level Selection (LEV¹) screen in the Pulse Region Setup screens, select the Pulse Level value (as a percentage of the total range, 0–100%) below which the output generates a pulse output signal instead of the standard 0-10 VDC output signal that it generates for the rest of output signal range. Select a LEV¹ value that is greater than the required minimum speed reference for the EC motor that the output is controlling. For example, if the minimum speed reference for your motor is 2 VDC (20% of the 0-10 VDC signal range), select 25(%) for the LEV¹ value. The Pulse Region Setup screens are available only on Analog Output 1 on the hybrid analog output control module. See [Sensor Failure Mode](#) and [Setting up a Pulse Region Hybrid Analog Output](#) for more information.

Main Screens

The default screens that auto-scroll on the LCD during normal control system operation. The Main screens display the sensor status for each hard-wired and functional sensor on the standard control systems. In reset control systems, the Main screens also display the Time screen, when the Time parameters are set up. From the Main screens, press **Next** (repeatedly) to manually scroll through the sensor status and output status screens. From the Main screens, press and hold **Up** and **Down** simultaneously for 5 seconds to go to the System Setup screens. See [Accessing and Navigating the User Interface](#) and [Viewing the System Status Screens](#) for more information.

Normally Closed (N.C.)

Normally Closed (N.C.) relay contacts are closed when the relay is not energized/activated and open when the relay is energized. On System 450 Relay Outputs, the LCy and LNCy terminals connect to the Normally Closed contacts. See [Relay Outputs](#) for more information.

Normally Open (N.O.)

Normally Opened (N.O.) relay contacts are open when the relay is not energized/activated and closed when the relay is energized. On System 450 Relay Outputs, the LCy and LNOy terminals connect to the Normally Opened contacts. See [Relay Outputs](#) for more information.

OEP^x

In the Percent Output Signal Strength at End Point Selection (OEP^x) screen in the Analog Output Setup screens, select the value (0 to 100%) of the total signal strength, to be generated by analog output x when the controlled condition is at the selected End Point (EP) value. See [Direct and Reverse Control Actions for Analog Outputs](#) and [Analog Output Setup](#) for more information.

OFFd

In the Off Delay (OFFd^x) screen in the Relay Setup screens, select the number of seconds (0 to 300) that the output relay x delays going Off after the Off condition is reached. See [Relay On and Off Duration Control](#) for more information.

OFFS^x

In the Temperature Offset Selection (OFFS^x) screen in the Sensor Setup screens, select the value (in degrees) that you want the measured (and displayed) temperature value to differ from the actual sensed temperature value. System 450 allows you to select a offset for each temperature sensor in your System 450 control system. You cannot select an offset for pressure or humidity sensors. The x value is the ID number for the temperature sensor you are setting up (Sn-1, Sn-2, or Sn-3). See [Setting Up the Sensors and Transducers](#) for more information.

OFFT^x

In the Minimum Off-Time Selection (OFFT^x) screen in the Relay Setup screens, select the number of seconds (0 to 300) that output relay x remains Off after being driven Off by control loop conditions. The minimum off-time feature is typically used to prevent short-cycling of controlled equipment. See [Setting up a Relay Output](#) for more information.

ONd

In the On Time Delay (ONd^x) screen in the Relay Setup screens, select the number of seconds (0 to 300) that the output relay x delays going On after the On condition is reached. See [Relay On and Off Duration Control](#) for more information.

ONT^x

In the Minimum On-Time (ONT^x) screen in the Relay Setup screens, select the number of seconds (0 and 300 seconds) that relay output x remains On after being driven On by control loop conditions. The minimum on-time feature is typically used to prevent short-cycling of controlled equipment. See [Setting up a Relay Output](#) for more information.

OSP^x

In the Percent Output Signal Strength at Setpoint (OSP^x) screen in the Analog Output Setup screens, select the value (0 to 100%) of the total signal strength, to be generated by analog output when the controlled condition is at the selected Setpoint (SP) value. The x value is the ID number for the output you are setting up. See [Direct and Reverse Control Actions for Analog Outputs](#) and [Analog Output Setup](#) for more information.

OUTA^x

In the Analog Output Setup Start (OUTA^x) screen, press **Next** to set up or edit the Analog Output Setup screens, or press **M** to go to the next Output Setup Start screen or return to the Sensor Setup screens. The x value is the ID number for the output you are setting up. See [Accessing the System Setup Screens](#) and [Analog Output Setup](#) for more information.

OUTR^x

In the Relay Output Setup Start (OUTR^x) screen, press **Next** to set up or edit the Relay Output Setup screens, or press **M** to go to the next Output Setup Start screen or return to the Sensor Setup screens. The x value is the ID number for the output you are setting up. See [Accessing the System Setup Screens](#) and [Relay output setup](#) for more information.

PER¹

In the Pulse Period Selection screen (PER¹) in the Pulse Region Setup screens, select the pulse period value (in seconds between 0 and 30) for your EC motor application. For PENN by Johnson Controls EC motors, select a value of 2 (seconds). For other EC motors, start with a value of 1 (second), test the motor application, and increase the value until the optimal pulse period is determined. The Pulse Region Setup screens are available only on Analog Output 1 on the hybrid analog output control module. See [Setting up a Pulse Region Hybrid Analog Output](#) for more information.

Proportional (Only) Control

Adjusts the control output signal in proportion to the difference between the sense value of the condition and the Setpoint (SP) value for the condition. Proportional (only) controls drive the condition to a control point within the proportional band between End Point (EP) and SP, but not all the way to SP. The larger the load on the system, the further the control point deviates from the target SP value. Proportional (only) control applications are relatively stable and easy to set up, and often the difference between Setpoint and control point (offset error) is predictable and can be compensated for by selecting a SP with offset error calculated into the selection. See [Proportional Plus Integral Control and Integration Constants](#) for more information.

Proportional Plus Integral (P-I) Control

Incorporates a time-integral control action with proportional control action and, if properly set up, a PI control loop can effectively eliminate offset error and enable a controlled system to drive to setpoint even under large constant loads. On a properly sized system with predictable loads, PI control can maintain the controlled system very close to setpoint. See [Proportional Plus Integral Control and Integration Constants](#) for more information.

PSI

When a pounds per square inch (psi) pressure sensor is set up in your control system, PSI appears in the Main (sensor status) screens, along with the current sensed pressure value. PSI sensors include Sensor Types P 100, P 110, P 200, P 500, and P 750. See [Accessing and Navigating the User Interface](#) and [System 450 Sensors and Transducers for Standard Control Modules](#) for more information.

Relay Output

System 450 provides Single-Pole, Double-Throw (SPDT) relay outputs rated to 240 VAC. The relay outputs can be set up to provide a wide variety of on/off control applications, including multi-stage control applications. Relay outputs are identified in the System 450 UI as OTR in the Output Setup Start screens and with ON or OFF in the System Status screens. See [Relay Outputs, Relay output setup](#), and [Viewing the System Status Screens](#) for more information.

Reset Control Modules

Provide Reset Setpoint (RSP) control, real-time clock, Setback scheduling (SbK) control, and run-time balancing, in addition to providing many of the features and control types provided by standard control modules. Reset control modules include the C450RxN-x models. Reset control modules do not control pressure applications and do not provide Differential Control, High Input Signal Selection, or Hybrid Analog Output control. Communication modules do not provide Reset Setpoint control, real-time clock, Setback scheduling control, or run-time balancing. Refer to the *System 450™ Series Modular Control Systems with Reset Control Modules Technical Bulletin (LIT-12011842)* for more information.

Reverse Acting

With Reverse Acting proportional control, an increase in the sensor signal results in a proportional decrease of the output signal generated to the controlled equipment and vice versa. See [Direct and Reverse Control Actions for Analog Outputs](#) for more information.

Sensor Type

Each System 450 compatible sensor and transducer model is associated with a specific Sensor Type. Each Sensor Type provides the setup parameters that define the condition (temperature, pressure, or humidity), unit of measurement, usable range, resolution, and minimum proportional band for the associated sensor and the outputs that reference the sensor. You must select a Sensor Type for each sensor connected to your control system (Sn1, Sn2, and Sn3) when you set up the sensors for your control system. When you select a hard-wire sensor or a functional sensor as an output's reference sensor, the output uses the Sensor Type parameters to define the output's setup parameters. See [System 450 Compatible Sensors and Transducers](#) and [Setting Up the Sensors and Transducers](#) for more information.

SENS^x

SENS appears in several screens in the System 450 UI and is associated with either the initial sensor setup screens, or the sensor selection and sensor edit screens in the output setup screens. In the Sensor Setup Start (SENS) screen, press **Next** to go to the Sensor Setup screens and set up the hard wire sensors for your control system. There is no output ID number (x) in the Sensor Setup Start screen. See [Setting Up the Sensors and Transducers](#) for more information. In the Sensor Selection (SENS^x) screen at the start of the Output Setup screens, select the sensor that you want output x to reference. You can select a sensor or transducer that is hard-wired to the control module (Sn-1, Sn-2, or Sn-3) or you can select a functional sensor (Sn-d, HI-2, HI-3, or rES). After you select the referenced sensor, the firmware provides the output setup parameter values in the remaining Output Setup screens according to the Sensor Type associated with the selected sensor. In the Edit Sensor (SENS^x) screen at the end of the Output Setup screens, you can select a different sensor

for the output to reference. If you do not want to change the selected sensor for output x, press Next to save the output setup values and return to the Output Setup Start screen. If you select a different sensor in the Edit Sensor (SENS^x) screen, you must set up the output again for the new sensor parameter values. See [Relay output setup](#) and [Analog Output Setup](#) for more information.

Sn-1

Input Sensor 1 (Sn-1) as identified in the System 450 UI. Outputs that reference Sn-1 reference the sensor or transducer that is hard-wired to the Sn1 terminal and a Common (C) terminal on the low-voltage terminal block on the system's control module. On standard System 450 control systems, the Sn-1 sensor is also used to create the functional Differential Control sensor (Sn-d) and the High Input Signal Selection feature (HI-2, HI-3). See [System 450 Compatible Sensors and Transducers](#) and [Setting Up the Sensors and Transducers](#) for more information.

Sn-2

Input Sensor 2 (Sn-2) as identified in the System 450 UI. Outputs that reference Sn-2 reference the sensor or transducer that is hard wired to the Sn2 terminal and a Common (C) terminal on the low-voltage terminal block on the system's control module. On standard System 450 control systems, the Sn-2 sensor is also used to create the functional Differential Control sensor (Sn-d) and the High Input Signal Selection feature (HI-2, HI-3). See [System 450 Compatible Sensors and Transducers](#) and [Setting Up the Sensors and Transducers](#) for more information.

Sn-3

Input Sensor 3 (Sn-3) as identified in the System 450 UI. Outputs that reference Sn-3, reference the sensor or transducer that is hard wired to the Sn3 terminal and a Common (C) terminal on the low-voltage terminal block on the system's control module. On standard System 450 control systems, the Sn-3 sensor is also used to create the High Input Signal Selection feature (HI-3). See [System 450 Compatible Sensors and Transducers](#) and [Setting Up the Sensors and Transducers](#) for more information.

Sn-d

The functional Differential Control sensor (Sn-d) as identified in the System 450 UI. Sn-d is available on standard System 450 control systems (only), when Sn-1 and Sn-2 are the same Sensor Type. The differential control value (Sn-d) is defined as $Sn-d = (Sn-1) - (Sn-2)$. Differential Control is available only on standard control modules and communication control modules. See [Differential Control](#), [System 450 Compatible Sensors and Transducers](#), and [Setting Up the Sensors and Transducers](#) for more information.

SNF^x

In the Sensor Failure Mode (SNF^x) screen in the Output Setup screens, select the mode of operation for output x in the event that a sensor (or associated sensor wiring) that the output references fails. SNF modes for relay outputs are ON and OFF. SNF modes for analog outputs are ON (=OEP) or OFF (=OSP). See [Sensor Failure Mode](#) for more information.

SP^x

In the Setpoint (SP) Selection screen in the Analog Output Setup screens, select the target value that analog output x is driving the control loop towards and away from the End Point (EP) value. The SP and EP values define the proportional band that the analog output is intended to control the condition within. See [Direct and Reverse Control Actions for Analog Outputs](#) for more information.

SSID

SSID stands for Service Set Identifier. SSIDs are an up to 32-character, unique identifier used to allow wireless devices to communicate with other devices on the wireless network that uses the same SSID.

Standard Control Modules

Provide on/off relay control, direct and reverse acting proportional analog control, multi-stage control, multi-purpose control, stand-alone control, and proportional plus integral control. Standard control modules include the C450CxN-x models. Standard control modules with Version 2.00 and later firmware also provide Differential Control and High Input Signal Selection. Standard control modules do not provide reset control, real-time scheduling, setback control, run-time balancing or hybrid analog output control.

System Setup Screens

Enable you to select the values that determine how your control system operates and the condition ranges that your system controls. Depending on the control module type and firmware version, your System Setup screens can include Sensor Setup screens, Relay Output Setup screens, and/or Analog Output Setup screens. You access the System Setup screens by navigating to the various System Setup Start screens. See [Accessing the System Setup Screens](#) for more information.

System Status Screens

Provide the current status of each sensor and output in your control system. You access the System Status screens by pressing **Next** repeatedly, when the Main screens are auto-scrolling on the display. See [Viewing the System Status Screens](#) for more information.

UP-R

In the Select Output Signal Update Rate (UP-R^x) screen in the Analog Output Setup screens, select the minimum update rate value, in seconds (1–240), at which the control updates an analog output's signal strength. See [Analog Output Update Rate](#) for more information.

Product warranty

This product is covered by a limited warranty, details of which can be found at www.johnsoncontrols.com/buildingswarranty.

Single point of contact

APAC	Europe	NA/SA
JOHNSON CONTROLS C/O CONTROLS PRODUCT MANAGEMENT NO. 32 CHANGJIJANG RD NEW DISTRICT WUXI JIANGSU PROVINCE 214028 CHINA	JOHNSON CONTROLS WESTENDHOF 3 45143 ESSEN GERMANY	JOHNSON CONTROLS 507 E MICHIGAN ST MILWAUKEE WI 53202 USA

Contact information

Contact your local branch office: www.johnsoncontrols.com/locations

Contact Johnson Controls: www.johnsoncontrols.com/contact-us