



Compressor
Voltage Code : FZ

AE4456N-FZ1C

High Temp. Commercial (HP)

220 - 240V 1~ 50 Hz

R1234yf / R134a / R513A

AE4456N-FZ1C

Conditions	Frequency	Nominal Cooling Capacity		Sound Power ISO3745 / ISO 3743-1
		Watts	BTU/h	
EN12900_HP / R1234yf	50 Hz	1218	4152	60 dBA
EN12900_HP / R134a	50 Hz	1282	4371	60 dBA
EN12900_HP / R513A	50 Hz	1304	4447	

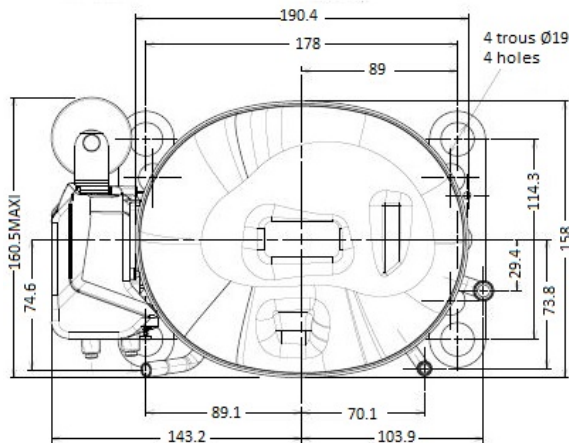
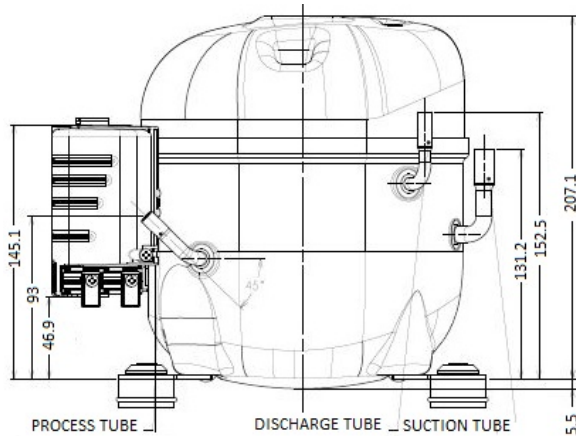

* EN12900_HP : T°Cond. 50.0°C / T°Evap. 5.0°C / T°Return gas temp.. 20.0°C
T°Subcooling. 0.0K

Displacement (cc)	14,51
Net Weight (Kg)	11.3
Oil Quantity (cc)	380.0
Oil Type	Polyolester
Expansion Device	Capillary_Tube/Expansion_Valve
Cooling	Fan
Main Winding (Ohm)	4.09
Start Winding (Ohm)	22.86
Current	
RLA (A)	3,7
MCC (A)	5,1
LRA (A)	17,5
Electrical Equipment	CSIR
Overload	MSP28APW
Time Check	2.8s - 5.2s / 25 A
Open Temp	135° C
Close Temp	61° C
Start Capacitor	64 µF / 250 V
Current Relay	MTRP0030
Pick Up	9,15A
Drop Out	7,7A
Refrigerating connection for	
Suction Tube	9.5 (3/8")
Discharge Tube	6.35 (1/4")
Process Tube	6.35 (1/4")

Note : Tecumseh reserves the right to change information contained in this document without notification.



Tecumseh

AE4456N-FZ1C	Tension FZ : 220 - 240V 1~ 50 Hz
---------------------	---

Les performances sont données dans les conditions EN12900_HP :	Gaz aspirés :	20.0 °C
Condition Dew	Sous refroidissement :	0.0 K
The performance data are in EN12900_HP conditions :	Return gas :	20.0 °C
Dew Condition	Subcooling :	0.0 K

© 2023 Tecumseh Products Company
All rights reserved

50 Hz R1234yf

N°3292

4 T condensation	5 T évaporation	(°C)	-25	-20	-15	-10	-5	0	5	10	15
30	1 P frigorifique	(Watt)	456	596	752	928	1125	1346	1594	1872	2181
	2 P absorbée	(W)	297	332	365	397	431	468	510	559	616
	3 I absorbée	(A)	2.76	2.81	2.88	2.96	3.06	3.18	3.32	3.50	3.71
40	1 P frigorifique	(Watt)	369	501	647	809	989	1191	1415	1666	1945
	2 P absorbée	(W)	309	353	394	432	470	509	551	598	652
	3 I absorbée	(A)	2.68	2.79	2.89	3.00	3.13	3.27	3.43	3.61	3.83
50	1 P frigorifique	(Watt)		407	539	683	843	1020	1218	1438	1683
	2 P absorbée	(W)		368	419	466	511	555	600	649	702
	3 I absorbée	(A)		2.79	2.94	3.09	3.24	3.41	3.59	3.79	4.01
60	1 P frigorifique	(Watt)			435	558	693	843	1010	1196	1404
	2 P absorbée	(W)			438	497	552	604	656	709	764
	3 I absorbée	(A)			3.00	3.19	3.38	3.58	3.78	4.00	4.24

50 Hz R134a

N°3298

4 T condensation	5 T évaporation	(°C)	-25	-20	-15	-10	-5	0	5	10	15
30	1 P frigorifique	(Watt)	420	554	712	897	1114	1366	1659	1997	2383
	2 P absorbée	(W)	275	307	337	367	397	429	464	502	544
	3 I absorbée	(A)	2.55	2.60	2.66	2.73	2.82	2.91	3.02	3.14	3.27
40	1 P frigorifique	(Watt)	353	479	624	792	987	1214	1476	1779	2125
	2 P absorbée	(W)	288	329	368	406	443	481	521	563	609
	3 I absorbée	(A)	2.50	2.60	2.70	2.82	2.95	3.09	3.24	3.41	3.58
50	1 P frigorifique	(Watt)		404	534	682	854	1052	1282	1547	1853
	2 P absorbée	(W)		345	394	442	489	535	583	632	684
	3 I absorbée	(A)		2.62	2.77	2.93	3.10	3.29	3.48	3.69	3.91
60	1 P frigorifique	(Watt)			447	574	720	888	1083	1310	1571
	2 P absorbée	(W)			416	476	534	592	649	708	769
	3 I absorbée	(A)			2.85	3.05	3.27	3.50	3.74	4.00	4.26

1 = cooling capacity 2 = power input 3 = current 4 = condensing temperature 5 = evaporating temperature

Nota : Tecumseh se réserve le droit de modifier les informations contenues dans ce document sans préavis.

Note : Tecumseh reserves the right to change information contained in this document without notification.



Tecumseh

AE4456N-FZ1C	Tension FZ : 220 - 240V 1~ 50 Hz
---------------------	---

Les performances sont données dans les conditions EN12900_HP :	Gaz aspirés :	20.0 °C
Condition Dew	Sous refroidissement :	0.0 K
The performance data are in EN12900_HP conditions :	Return gas :	20.0 °C
Dew Condition	Subcooling :	0.0 K

50 Hz R513A											
											N°3496
4 T condensation	5 T évaporation	(°C)	-25	-20	-15	-10	-5	0	5	10	15
30	1 P frigorifique	(Watt)	484	626	789	974	1187	1429	1704	2016	2368
	2 P absorbée	(W)	306	337	365	393	423	458	499	550	613
	3 I absorbée	(A)	2.83	2.85	2.88	2.93	3.00	3.11	3.25	3.44	3.69
40	1 P frigorifique	(Watt)	398	530	680	850	1044	1265	1517	1803	2126
	2 P absorbée	(W)	314	358	396	432	469	507	551	601	661
	3 I absorbée	(A)	2.74	2.82	2.91	3.01	3.12	3.26	3.43	3.63	3.89
50	1 P frigorifique	(Watt)		438	569	718	888	1082	1304	1557	1845
	2 P absorbée	(W)		367	420	468	515	561	611	665	727
	3 I absorbée	(A)		2.79	2.95	3.10	3.27	3.45	3.65	3.88	4.15
60	1 P frigorifique	(Watt)			469	591	730	892	1078	1294	1541
	2 P absorbée	(W)			435	500	560	619	678	740	808
	3 I absorbée	(A)			2.98	3.21	3.43	3.66	3.91	4.18	4.47

© 2023 Tecumseh Products Company
All rights reserved

1 = cooling capacity 2 = power input 3 = current 4 = condensing temperature 5 = evaporating temperature

Nota : Tecumseh se réserve le droit de modifier les informations contenues dans ce document sans préavis.
Note : Tecumseh reserves the right to change information contained in this document without notification.