



## Differential valves for oil receivers

### → HCYCT (non adjustable) / HCYCTR (adjustable)

#### ■ Applications

- Differential valves are used on low pressure oil return systems of refrigerating and air conditioning installation.
- They are mounted on oil receivers in which they maintain a permanent overpressure compared to the compressor crankcases in order to ensure them a constant oil distribution. This is the guarantee of a regular and permanent oil reintegration.
- Therefore, the oil which is returned to the compressor crankcases is free from refrigerant as, should any refrigerant come from the oil separator, it would be expanded in the oil receiver and drained out to the suction line via the differential valves.

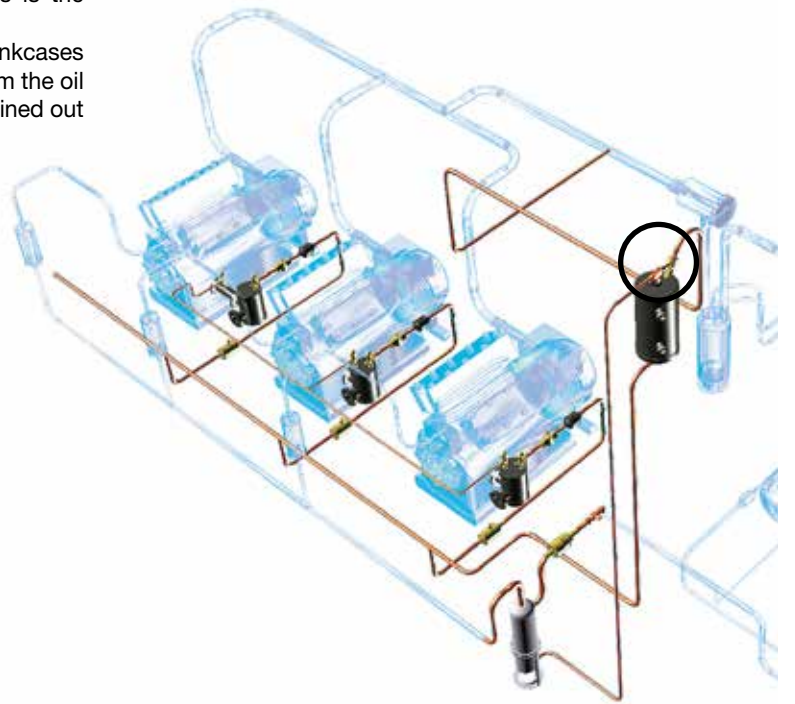

#### ■ Functional features

- Products are compatible with HCFCs, CFCs, HFOs, CO<sub>2</sub> as well as with their associated oils and additives. Products are designed for use of non-hazardous refrigerants from group 2 of PED 2014/68/EU. To use CARLY components with fluids of the hydrocarbon group 1, contact CARLY technical department.
- Product classification in CE categories is performed using the PED 2014/68/EU table, corresponding to a nominal diameter-based selection.
- On adjustable differential valve HCYCTR:
  - Body and internal mechanism in brass
  - Valve spring strictly calibrated
  - PTFE gaskets.
- Adjustable differential valve HCYCTR:
  - Painted steel body with internal phosphating
  - Connection to the oil receiver orientable at 360° with a swivel nut 3/8" SAE
  - Screwed plug perfectly sealed to prevent any accidental handling of the adjustment rod
  - Internal Neoprene® sealing gasket.
- A 3/8" copper gasket is provided with the HCYCT and HCYCTR differential valves.

#### ■ CARLY advantages

- Maximum working pressure: 46 bar
- HCYCT: 4 models of non adjustable differential valves with set pressures of 0.35, 1.4, 3.5 and 7 bar.
- The HCYCT 7 is suitable for working with high pressure differential (7 bar) such as CO<sub>2</sub> installations.
- HCYCTR: 1 model of adjustable differential valve allowing a possible adjustment of the set pressure with a rod handled with a tool (square section of 7,8 mm), from 0.35 bar to 3.5 bar. Adjustment in factory : 1,4 bar.
- The HCYCTR allow to very precisely adjust the differential of pressure, according to the characteristics of the compressors and the components of the oil return system.
- The possibility to adjust the pressure differential enables to solve some problems of oil return.



# Differential valves for oil receivers

## → HCYCT (non adjustable) / HCYCTR (adjustable)

### ■ Warning

Before selecting or installing any component, please refer to the chapter 0 - **WARNING**.

### ■ General assembly precautions

The installation of a component in a refrigeration system by a skilled professional, requires some precautions:

- Some are specific to each component, and in this case, they are specified in the

**RECOMMENDATIONS SPECIFIC** part defined hereafter ;

- Other are general to all CARLY components, they are presented in the chapter 115 – **GENERAL ASSEMBLY PRECAUTIONS**.

- The recommendations relating to the CARLY components for the subcritical CO<sub>2</sub> applications are also developed in chapter 115 – **GENERAL ASSEMBLY PRECAUTIONS**.

### ■ Recommendations specific to the differential valves HCYCT / HCYCTR

- The differential valves are to be mounted on the 3/8" SAE connection located in the higher part of the oil receiver by its female connection and connected to the suction line by its male connection.
- Be sure to comply with the flow direction indicated by an arrow engraved on the body of the differential valves.
- The tightening of the differential valves must imperatively be made with two open-end spanners, in order to avoid the twisting of the pipes, and the deterioration

of their brass body (tightening with pliers proscribed).

- On some multi-compressors installations, one or several compressors can operate at different suction pressures; in order to ensure correct oil feeding of all compressors, it is necessary to select the differential valves so as to establish a minimum overpressure of 0.35 bar between the oil receiver and the compressor with the highest suction pressure (refer to the selection example

chapter 49 - oil level regulators LEVOIL).

- On installations equipped with bi-level compressors or «Booster» system, it is recommended to connect the differential valves to the intermediary level suction line.
- For HCYCT/HCYCTR differential valves, carefully watch the correct positioning of the supplied copper seals.
- After every disassembly of the valves, it is imperative to replace the copper gasket before the re-assembly.

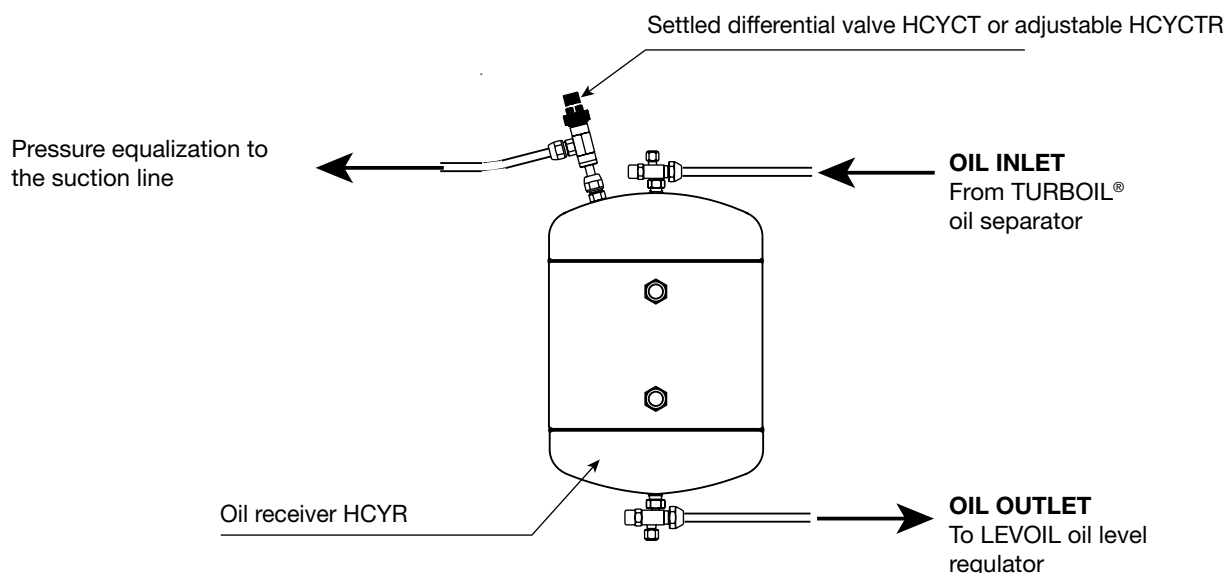



# Differential valves for oil receivers

CTCY-EN - 44.1-6 / 11-2022

## → HCYCT (non adjustable)

### ■ Technical features

CARLY references	Connections to screw SAE inch		Pressure range bar	Dimensions mm	
	Inlet Female	Outlet Male		H upper faces	L
HCYCT 1	3/8	3/8	0,35	21	65
HCYCT 3	3/8	3/8	1,40	21	65
HCYCT 4	3/8	3/8	3,50	21	65
HCYCT 7	3/8	3/8	7,00	21	65

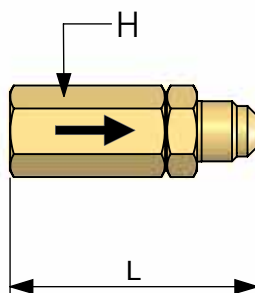

CARLY references	Nominal diameter	Maximal working pressure	Working pressure <sup>(1)</sup>	Maximal working temperature	Minimal working temperature	Working temperature <sup>(1)</sup>	CE Category <sup>(2)</sup>
	DN inch	PS bar	PS BT bar	TS maxi °C	TS mini °C	TS BT °C	
HCYCT 1	3/8	46	15	120	-40	-30	Art4§3
HCYCT 3	3/8	46	15	120	-40	-30	Art4§3
HCYCT 4	3/8	46	15	120	-40	-30	Art4§3
HCYCT 7	3/8	46	15	120	-40	-30	Art4§3

<sup>(1)</sup> The working pressure is limited to the PS BT value when working temperature is lower than or equal to TS BT value.

<sup>(2)</sup> Classification by diameter, according to PED 2014/68/EU (refer to chapter 0).



CTCY-EN - 44.1-6 / 11-2022

# Differential valves for oil receivers

## → HCYCTR (adjustable)

### ■ Technical features

CARLY references	Connections to screw SAE inch		Pressure range bar	Dimensions mm						
	Inlet Female	Outlet Male		H1 upper faces	H2 upper faces	H3 upper faces	H4 upper faces	L	E1	E2
HCYCTR	3/8	3/8	0,35 à 3,50	22	17	20	21	122	54	39

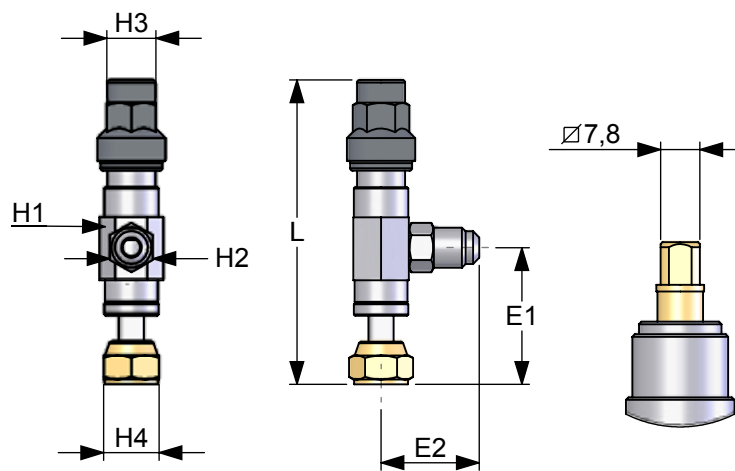

CARLY references	Nominal diameter	Maximal working pressure	Working pressure (1)	Maximal working temperature	Minimal working temperature	Working temperature (1)	CE Category (2)
	DN inch	PS bar	PS BT bar	TS maxi °C	TS mini °C	TS BT °C	
HCYCTR	3/8	46	15	120	-40	-30	Art4&3

(1) The working pressure is limited to the PS BT value when working temperature is lower than or equal to TS BT value.

(2) Classification by diameter, according to PED 2014/68/EU (refer to chapter 0).



# Differential valves for oil receivers

CTCY-EN - 44.1-6 / 11-2022

## → HCYCT (non adjustable) / HCYCTR (adjustable)

### ■ Spare parts

CARLY references		Part Nb	Description	Quantity
Valves for receivers	Spare parts			
HCYCT	CY 15590025	1	Set of 25 taper guided copper gaskets for 3/8" SAE connection	1
HCYCTR	CY 10870010	2	Plug for inspection rod	1
HCYCTR	CY 15590020	3	Set of 25 taper copper gaskets for 3/8" SAE connection	1

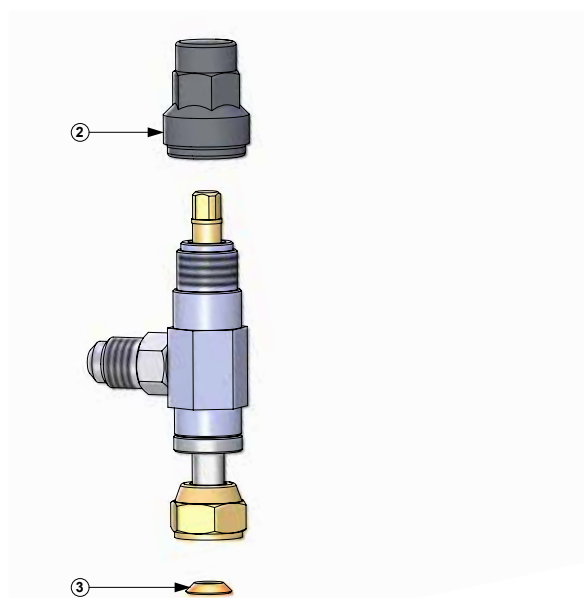
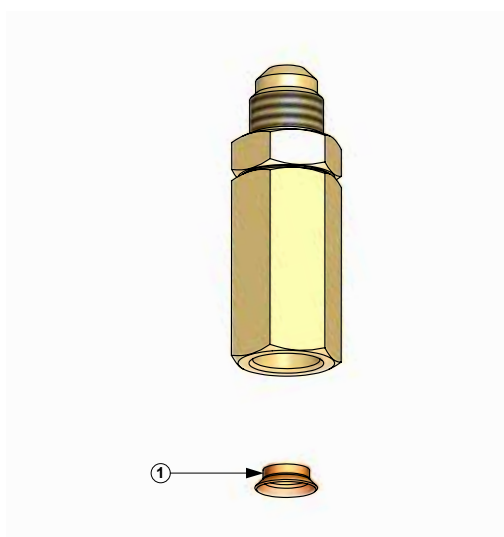

### ■ Weights and packaging

CARLY references	Unit weight kg		Packaging number of pieces
	With packaging	Without packaging	
HCYCT 1	0,16	0,15	1
HCYCT 3	0,16	0,15	1
HCYCT 4	0,16	0,15	1

CARLY references	Unit weight kg		Packaging number of pieces
	With packaging	Without packaging	
HCYCT 7	0,16	0,15	1
HCYCTR	0,23	0,20	1