

Data Sheet

# Thermostatic expansion valve Type **TE2 for R744**

For high pressure (CO<sub>2</sub> - 90 bar / 1305 psi)



Thermostatic expansion valves regulate the injection of refrigerant liquid into evaporators.

Injection is controlled by the refrigerant superheat.

Therefore the valves are especially suitable for liquid injection in "dry" evaporators where the superheat at the evaporator outlet is proportional to the evaporator load.

With this new TE 2 version for CO<sub>2</sub>, the use of a manual TXV together with a simpler case controller, create the unique possibility for building a CO<sub>2</sub> system, with a lower initial investment. This while still allowing constant data logging of temperatures.

## Features

### Wide temperature range

- Equally applicable in MT and LT applications
- Is supplied with MOP (Max. Operating Pressure)

### Interchangeable orifice assembly

- easy storage
- easy capacity matching
- better service
- easy cleaning and replacement of filter

### Rated capacities from 1 to 10.5 kW / 0.3 to 3.0 TR for CO<sub>2</sub>

### Laser welded power element

- Ensures diaphragms structural integrity and increase working life

### Laser engraving

- Durable positive valve identification, no label that peels off over time

### Stainless steel capillary tube

- Flexible and lightweight capillary tube. Tolerates more bending for trouble free installation and longer life
- Greater resistance to vibration during operation, because of low weight

### Stainless steel bulb and Danfoss patented bulb strap

- Fast and easy to install
- Good temperature transfer from pipe to bulb

### Design protected

### Manufactured according to IATF 16949

**In order to allow capacities down to 1 kW / 0.3 TR R744, 4 new orifices (CZ, CY, CX and C0) have been designed. These orifices will be used together with existing ones**

## Portfolio overview

### Related products

#### Controllers:

Figure 1: EKC 202D and EKC 202D1



EKC 202D

EKC 202D1

Figure 2: AK-CC55 Compact



AK-CC55 Compact

Figure 3: AK-RC 111



AK-RC 111

**Solenoid valves:**

Figure 4: EVUL plus Coils



EVUL

## Functions

Figure 5: Functions

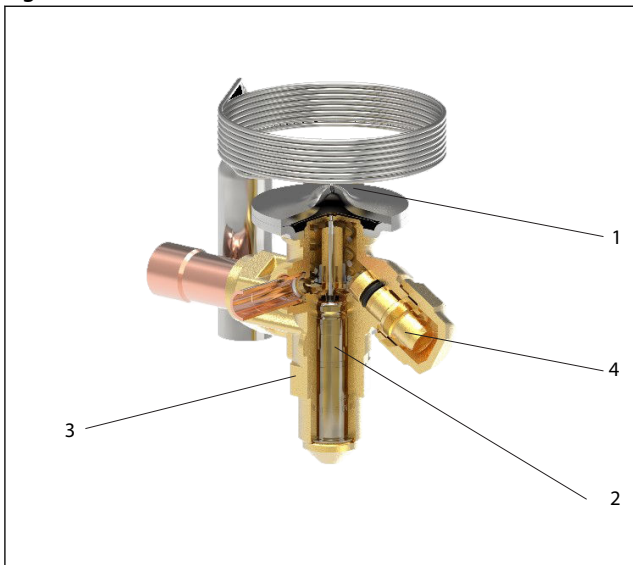

1	Thermostatic element (diaphragm)
2	Interchangeable orifice assembly
3	Valve body
4	Superheat setting spindle (see instructions)

Thermostatic expansion valves maintain a constant superheat level at the evaporator outlet. It does this by controlling the amount of refrigerant that is injected into the evaporator, taking both the evaporator load and ambient temperatures into consideration. This both optimizes the efficiency of the refrigeration system and prevents liquid refrigerant from entering the suction line, possibly causing damage to the compressor. Particularly when compared to systems that use capillary tubes, the thermostatic expansion valve will offer a significant energy saving.

The TE 2 valves for CO<sub>2</sub> will not be available with internal pressure equalization and to work on sub critical systems, these versions have been upgraded to MWP 90 bar.

TE2 valves have an interchangeable orifice assembly. The orifice assembly is suitable for all versions of valve body and refrigerants and in all evaporating temperature ranges. To ensure long operating life, the valve cone and seat are made of a special alloy with particularly good wear qualities.

The charge in the thermostatic element is adapted to the refrigerant and evaporating temperature and range, as laser engraved on the valve top.

The bulb gives fast and precise reaction to temperature changes in the evaporator. The bulb is fixed with a Danfoss patented bulb strap for quick, easy, and reliable mounting. This secures a good thermal contact to the suction tube.

## Applications

The TE 2 for CO<sub>2</sub> is developed for use as Thermostatic Expansion Valve for injecting in subcritical CO<sub>2</sub> applications. The valve is intended for use in smaller CO<sub>2</sub> systems where lower initial investments is considered a benefit. E.g., convenient stores or smaller Cold rooms. By using a mechanical TXV instead of an Electric Expansion Valve, a simpler case controller can be used and mounting of a pressure sensor in the case is not required

Figure 6: Simplified CO<sub>2</sub> system, showing how the TE2 valves can be used

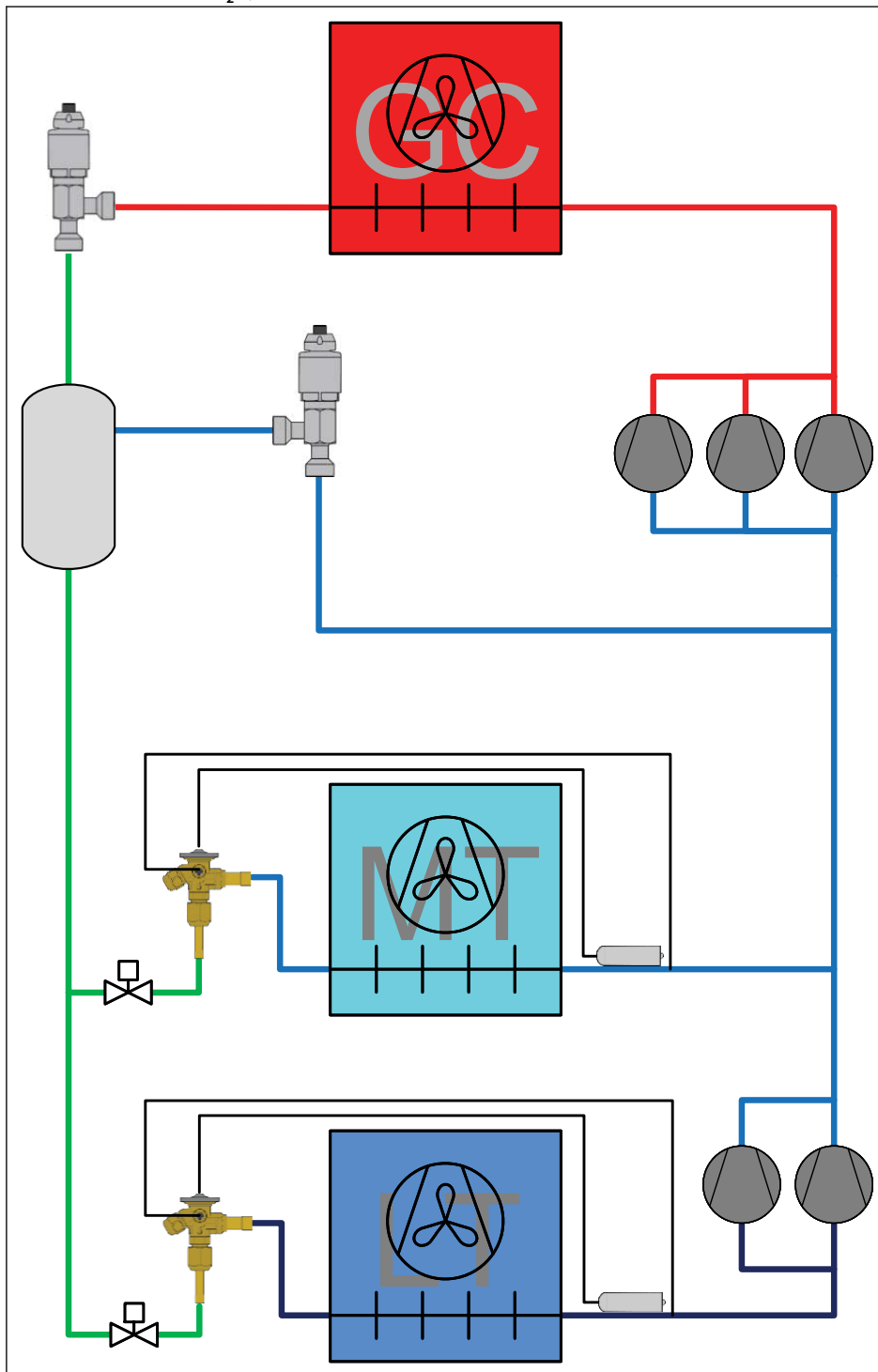
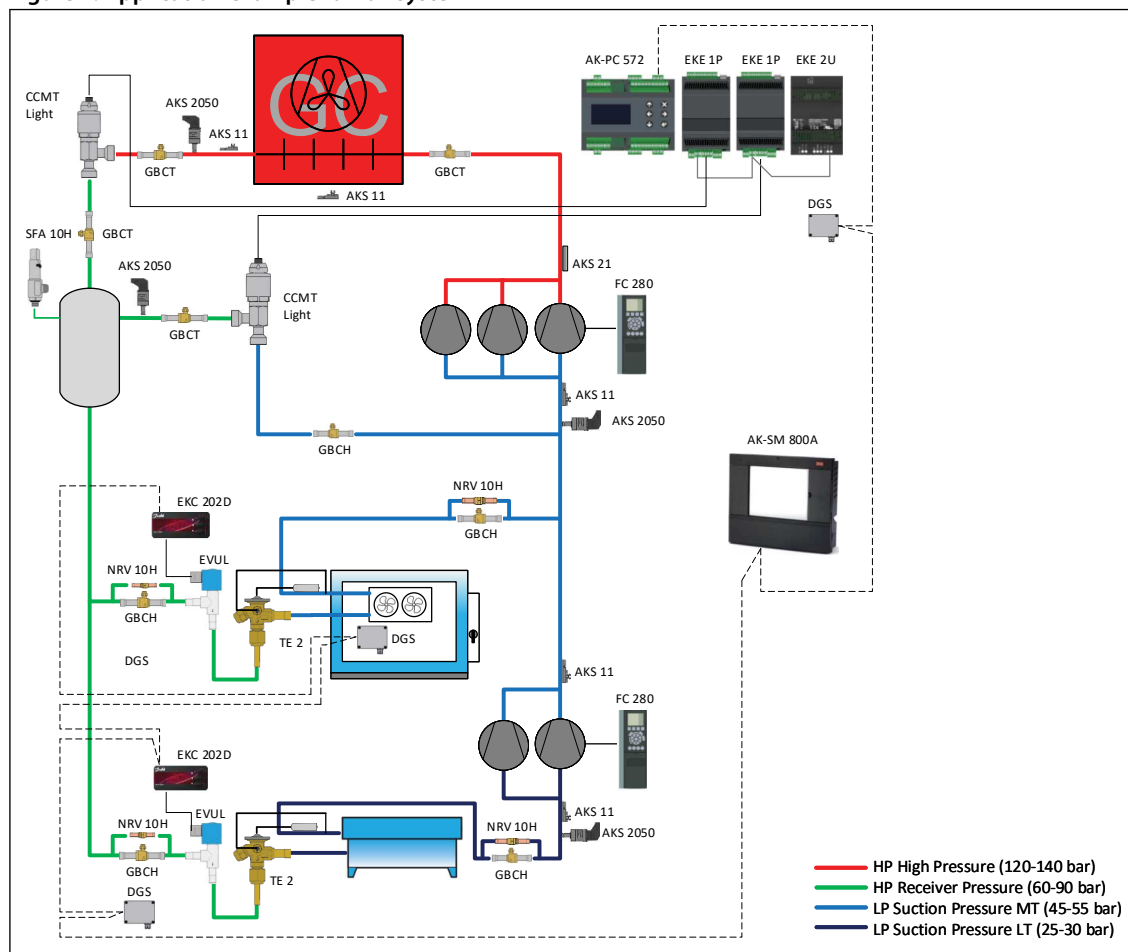

Figure 7: Application example for full system



- With this new TE 2 version for CO<sub>2</sub>, the use of a manual TXV together with a simpler case controller, create the unique possibility for building CO<sub>2</sub> systems with lower initial investments in the show case part of the system. Because a case controller is still used, temperatures can still be logged constantly
- Use of the TE 2 for CO<sub>2</sub> do not change the requirements for the rest of the system like compressors, gas cooler, receiver, and the like
- Typically used in combination with CO<sub>2</sub> condensing units, Self-contained units, and Semi plug-in units
- Can be used in both Cabinets and Cold rooms

## Product specification

### Technical data

#### Max. temperature

Bulb, when valve is installed: 100 °C / 212 °F

Bulb, element not mounted (during transport and storage): 65 °C / 149 °F

#### Min. temperature

TE2: -40 °C / 104 °F

#### Max. test pressure

PT = 99 barg / 1435 psig

#### Max. working pressure

PS/MWP = 90 barg / 1305 psig

Table 1: Technical data

Refrigerant	Range
	-40 °C – 0 °C / -40 °C – 32 °F
MOP-point in evaporating temperature $t_e$ and evaporating pressure $p_e$ <sup>(1)</sup>	
5 °C / 41 °F	
R744 (CO <sub>2</sub> )	640 psig / 44 bar (abs)

<sup>(1)</sup>  $p_e$  in bar gauge

### Superheat

SS	static superheat
OS	opening superheat
SH = SS + OS	total superheat
$Q_{nom}$	rated capacity
$Q_{max}$	maximum capacity

Standard static superheat setting SS is:

At MT conditions (T<sub>evap.</sub> = -10 °C / 14 °F): 2 K (2 °C / 3.6 °F)

At LT conditions (T<sub>evap.</sub> = -30 °C / -22 °F): 3 K (3 °C / 5.4 °C)

Static static superheat SS can be adjusted with setting spindle:

At MT conditions (T<sub>evap.</sub> = -10 °C / 14 °F): From 1 K to 5 K (1 °C / 1.8 °F to 5 °C / 9 °F)

At LT conditions (T<sub>evap.</sub> = -30 °C / -22 °F): From 1 K to 7 K (1 °C / 1.8 °F to 7 °C / 12.6 °F)

The opening superheat OS is 2 K (2 °C / 3.6 °F) from when opening begins to where the valve gives its rated capacity  $Q_{nom}$ .

#### Example

Static superheat SS = 2 K

Opening superheat OS = 2 K

Total superheat SH = 2 + 2 = 4 K

Table 2: Range: -40 to 0 °C

Orifice no.	Rated capacity in kW	
	MT	LT
CZ	1.44	1.66
CY	1.97	2.23
CX	2.19	2.42



## Thermostatic expansion valve, type TE 2 for R744, CO2

Orifice no.	Rated capacity in kW	
	MT	LT
C0	3.46	4.23
01	5.58	6.75
02	10.6	11.6
03	15.0	16.4

The rated capacity for MT conditions is based on:

Evaporating temperature  $t_e = -10\text{ °C}$

Condensing temperature  $t_c = 0\text{ °C}$

Refrigerant temperature ahead of valve  $t_1 = -1\text{ °C}$

The rated capacity for LT conditions is based on:

Evaporating temperature  $t_e = 30\text{ °C}$

Condensing temperature  $t_c = 0\text{ °C}$

Refrigerant temperature ahead of valve  $t_1 = -1\text{ °C}$

**Table 3: RangeN: -40 to 41 °F**

Orifice no.	R744 Rated capacity in tons (TR)	
	MT	LT
CZ	0.41	0.47
CY	0.56	0.64
CX	0.62	0.69
C0	0.98	1.21
01	1.59	1.92
02	3.02	3.30
03	4.28	4.68

The rated capacity for MT conditions is based on:

Evaporating temperature  $t_e = 14\text{ °F}$

Condensing temperature  $t_c = 32\text{ °F}$

Refrigerant temperature ahead of valve  $t_1 = 30\text{ °F}$

The rated capacity for LT conditions is based on:

Evaporating temperature  $t_e = -22\text{ °F}$

Condensing temperature  $t_c = 32\text{ °F}$

Refrigerant temperature ahead of valve  $t_1 = 30\text{ °F}$

## Dimensions and weights

**Figure 8: Flare × solder (All dimensions are in mm)**

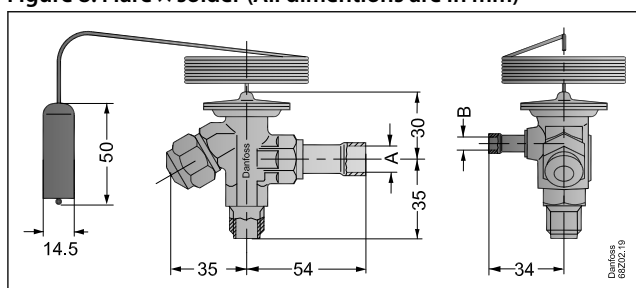

**Table 4: Dimensions and weights**

Outlet	Flare × solder		Weight [kg / lb]
	A	B	
1/2" solder 12 mm solder			0.3 / 0.7

## Thermostatic expansion valve, type TE 2 for R744, CO2

Figure 9: Solder adaptor

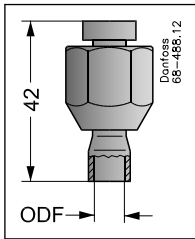
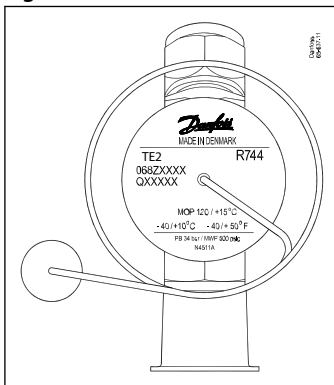

Table 5: Solder adaptor

Solder ODF		Weight
[in]	[mm]	[kg / lb]
1/4	6	0.05 / 0.11
3/8	10	0.05 / 0.11

## Identification

Figure 10: Identification



<b>TE2</b>	external equalization
<b>N</b>	Nordborg, Denmark
<b>45</b>	week
<b>11</b>	2011
<b>A</b>	Monday

### Production place and date N4511A

The thermostatic element has laser engraved data on top of the diaphragm. This engraving gives valve type (with code number), evaporating temperature range, MOP point, refrigerant, and max. working pressure. PS/MWP.

Figure 11: Orifice assembly and filter for TE 2 with Solder Adapter

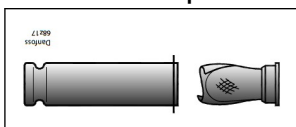

### Orifice assembly for T2 and TE2

The orifice assembly is marked with the orifice size (e.g. 06) and week stamp + last number in the year (e.g. 171) on the other side.

The orifice assembly number is also given on the lid of its plastic container.

Figure 12: Capillary tube label for TE2



### Capillary tube label for TE2

The label gives the orifice size (04) and consists of the lid of the orifice assembly plastic container. It can easily be fastened around the expansion valve capillary tube to clearly identify the valve size.

## Ordering

### **T2/TE 2 Thermostatic element with bulb strap**

#### Flare x solder

Figure 13: Flare x solder

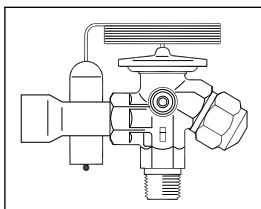

Capillary tube: 1.5 m  
Range = -40 – 0 °C

Table 6: Flare x solder

Refrigerant	Type	Range		MOP	Pressure equalization solder [in / mm]	Connection flare inlet x solder outlet		Code no. Multi pack
		[°C]	[°C]	[°C]		[in]	[mm]	
		[°F]	[°F]	[°F]				
R744	TE2	-40 – 0		5	1/4	3/8 x 1/2	-	068Z2900
		-40 – 32		41				
	TE2	-40 – 0		5	6	-	10 x 12	068Z2901
		-40 – 32		41				

#### Orifice assembly with filter for solder adaptor

Figure 14: Orifice assembly with filter for solder adaptor

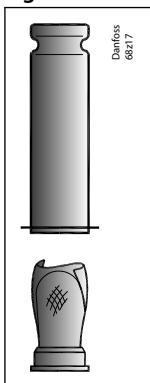
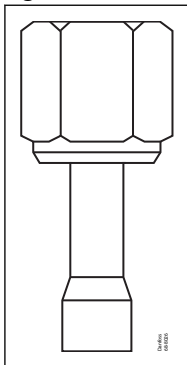

Table 7: Orifice assembly with filter for solder adaptor

Orifice no.	Code no.
CZ	068Z2100
CY	068Z2101
CX	068Z2102
C0	068Z2103
01	068-2091
02	068-2092
03	068-2093

## Solder adaptor

Figure 15: Solder adaptor



The adaptor is for use with thermostatic expansion valves T2 and TE2 with flare × solder connections. When the adaptor is fitted correctly it meets the sealing requirements of DIN 8964.

To secure an optimal leak free connection to the liquid line of the TE2 for CO<sub>2</sub>, the Solder Adapter MUST be used. Only in this way the sealing requirements of DIN 8964 can be fulfilled.

SAE flare nut assemblies cannot secure the needed leakage level required in DIN 8964

The adaptor offers the following advantages:

- The orifice assembly can be replaced.
- The filter can be cleaned or replaced.

When using the solder adapter, a special orifice assembly is required. Please use the following tables to select the appropriate adapter and, if needed, filter designed for use with the solder adapter.

Solder adaptor for filter drier (FSA) must not be used in the T2 inlet.

Table 8: Solder adaptor without orifice assembly and filter

Connection ODF solder	Code no.
1/4 in	068-2062
6 mm	068-2063
3/8 in	068-2060
10 mm	068-2061

Figure 16: Filter

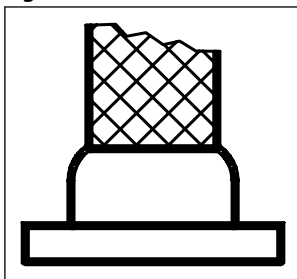
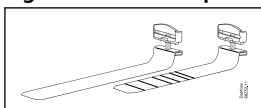

Table 9: Filter for solder adaptor

Description	Code no.
Filter excl. orifice assembly	068-0015

## Bulb strap (Danfoss patented)

Figure 17: Bulb strap



## Thermostatic expansion valve, type TE 2 for R744, CO2

Each valve is delivered with a Danfoss patented bulb strap. Spares can be ordered.

**Table 10: Bulb strap (Danfoss patented)**

Description	Pack mode	Quantity / pack	Code no.
Accessory bag with short bulb strap I/45	I	45	068U3525
Accessory bag with long bulb strap I/45	I	45	068U3527
Accessory bag with short bulb strap M/25	M	25	068U3520
Accessory bag with long bulb strap M/45	M	45	068U3528

## Ordering EVUL solenoid valve

**Figure 18: Valve type**

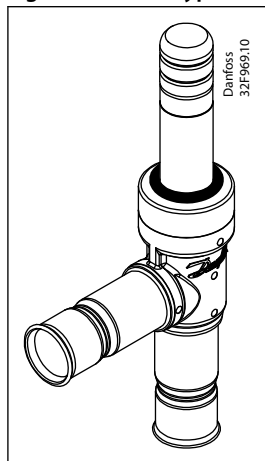

**Table 11: Normally closed (NC)**

Valve type	Connections	Industrial pack		Multi pack	Connections	Industrial pack		Multi pack
	[in.]	Code no.	Pcs.	Code no.	[mm]	Code no.	Pcs.	Code no.
EVUL 1	1/4	032F8200	40	-	6	032F8227	40	-
	1/4	-	-	032F9506	6	-	-	032F9508
EVUL 2	1/4	032F8201	40	032F9510	6	032F8228	40	032F9516
EVUL 3	1/4	032F8202	40	032F9511	6	032F8229	40	032F9517
	3/8	032F8203	40	-	10	032F8230	40	-
EVUL 4	1/4	032F8204	40	032F9512	6	032F8231	40	032F9518
	3/8	032F8205	40	-	10	032F8232	40	-
	1/2	032F8206	40	-	12	032F8233	40	-

Single pack = 1 product in a box with installation guide

Multi pack = box with x pieces single pack (can be split)

Industrial pack = x pieces in one box (cannot be split)

## Ordering coils for EVUL

If coils are below IP x 5, they must be protected against ultraviolet, moisture and major impact, especially the connection of coils.

Always Install a fuse ahead of the coil: rated current: two times of rated current, time lag: medium, to avoid short circuit.

The coil cannot be used in an area of more than pollution degree 2.

Follow the installation guide to mount the coil correctly, and apply o-ring for sealing to prevent moisture penetrating inside the coil

## Thermostatic expansion valve, type TE 2 for R744, CO2

Figure 19: DIN spade connection

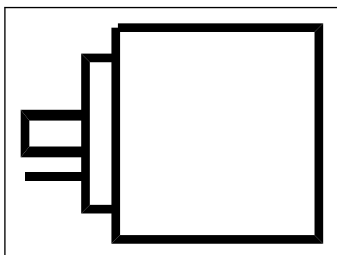

Table 12: Alternating current AC - with DIN plug <sup>1)</sup> - IP65

Type	Ambient Temp. [°C]	Supply voltage [V]	Voltage variation	Frequency [Hz]	Power consumption		Industrial packx		Multi pack
					[W]	[VA]	Code no.	Pcs.	Code no.
AS230CS	-40 – 50	230	-15% – 10%	50	8	16	-	-	042N7601
		208 – 240	-15% – 10%	60	7	14			

<sup>1)</sup> The three pins on the coil can be fitted with spade tabs, 6.3 mm wide (to DIN 46247). The two current carrying pins can also be fitted with spade tabs, 4.8 mm wide. Max. lead cross section: 1.5 mm<sup>2</sup>. If DIN plug is used (DIN 43650) the leads must be connected in the socket.

Figure 20: Cable connection

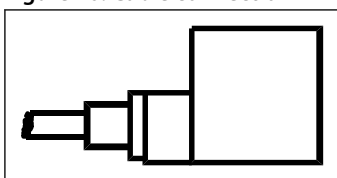

Table 13: Alternating current AC with 1 m cable - IP67

Type	Ambient Temp. [°C]	Supply voltage [V]	Voltage variation	Frequency [Hz]	Power consumption		Industrial packx		Multi pack
					[W]	[VA]	Code no.	Pcs.	Code no.
AU230CS	-40 – 50	230	-15% – 10%	50	7	14	042N8651	20	042N7651
		230	-15% – 10%	60	5	10			

## Accessories

Table 14: DIN plug

Part	Description	Multi pack	
		Code no.	Pcs.
	Din plug	042N1256	100

## Controllers

Table 15: EKC 202D / EKC 202D1

Type		Function	Voltage supply	Code no.
EKC 202D		Refrigeration controller without data communication but prepared for mounting of one module	230 V a.c.	084B8536

## Thermostatic expansion valve, type TE 2 for R744, CO2

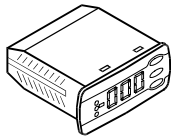
Type		Function	Voltage supply	Number	Code no.
EKC 202D1		Refrigeration controller without data communication but prepared for mounting of one module	230 V a.c.	1	084B8554
				30	084B8654

**Table 16: AK-CC 55 compact**

Type	Stat No: 69627 - Stat No Desc.: AK-CC 55	Packing	Qty.	Code no.
AK-CC 55 Compact	Case controller for AKV or solenoid valve (including connectors)	S/M-pack		084B4081

**Table 17: AK-RC 111**

Type	Code no.
OPTYMA™Control single-phase (2 HP) including two sensors	080Z3220

## How to select a valve

Example:

Refrigerant = CO<sub>2</sub>

Q (capacity) = 1.4 kW

Tcond (condensing temperature) = 25 °C

Tevap (evaporator temperature) = -10 °C

Tsub (subcooling temperature) = 2 K

Dpd (distributer pressure drop) = 1 bar

Q (capacity) = 1.4 kW

fsub (subcooling correction factor) = 1.0

fp (distribution correction factor) = 0.97

$$\frac{Q}{f_{sub} \times f_p} = \text{selected capacity}$$

$$\frac{1}{1.0 \times 0.97} = 1.44 \text{ kW}$$

The selection will be: TE2 orifice CX (1.64 kW > 1.44 kW)

**Table 18: Capacity in kW, range N -40 °C to 10 °C. Opening superheat sh= 2 K**

		R744 ( CO2)										
Valve type	Orifice no.	Cond. Temp. [°C]	Evaporating [°C]									
			-40	-35	-30	-25	-20	-15	-10	-5	0	
			Capacity [kW]									
TE 2	CZ	25	1.44	1.53	1.60	1.61	1.54	1.38	1.09	-	-	
TE 2	CY		1.92	2.05	2.14	2.16	2.09	1.88	1.48	-	-	
TE 2	CX		2.07	2.22	2.32	2.35	2.28	2.07	1.64	-	-	
TE 2	C0		3.76	3.96	4.06	4.02	3.81	3.36	2.59	-	-	
TE 2	01		5.94	6.29	6.47	6.44	6.12	5.42	4.19	-	-	
TE 2	02		9.67	10.5	11.1	11.4	11.1	10.0	8.00	-	-	
TE 2	03		13.7	14.9	15.7	16.1	15.7	14.2	11.3	-	-	

**Table 19: Subcooling correction factor 'fsub'**

Subcooling [K]	0	2	10	15	20	25
Correction factor	0.97	1.00	1.13	1.20	1.28	1.35

**Table 20: Distributer correction factor 'fp' \*)**

Pressure drop [bar]		Evaporating [°C]									
		-40	-35	-30	-25	-20	-15	-10	-5	0	
"Pressure drop [bar]"	0	1	1	1	1	1	1	1	1	1	
	1	0.99	0.98	0.98	0.98	0.98	0.98	0.97	0.97	0.95	
	1.5	0.98	0.98	0.98	0.97	0.97	0.97	0.96	0.95	0.92	
	2	0.97	0.97	0.97	0.96	0.96	0.95	0.94	0.93	0.90	

## Thermostatic expansion valve, type TE 2 for R744, CO<sub>2</sub>

\*) calculated at 10°C condensing temperature

### Capacity tables

Table 21: R744, Capacity in kW, opening superheat sh= 2 K

Valve type	Orifice no.	Cond. Temp. [°C]	Evaporating [°C]									
			-40	-35	-30	-25	-20	-15	-10	-5	-0	
			Capacity [kW]									
TE 2	CZ	-5	1.44	1.53	1.60	1.61	1.54	1.38	1.09	-	-	
TE 2	CY		1.92	2.05	2.14	2.16	2.09	1.88	1.48	-	-	
TE 2	CX		2.07	2.22	2.32	2.35	2.28	2.07	1.64	-	-	
TE 2	C0		3.76	3.96	4.06	4.02	3.81	3.36	2.59	-	-	
TE 2	01		5.94	6.29	6.47	6.44	6.12	5.42	4.19	-	-	
TE 2	02		9.67	10.5	11.1	11.4	11.1	10.0	8.00	-	-	
TE 2	03		13.7	14.9	15.7	16.1	15.7	14.2	11.3	-	-	
TE 2	CZ	0	1.48	1.59	1.69	1.74	1.74	1.65	1.46	1.13	-	
TE 2	CY		1.97	2.13	2.26	2.34	2.35	2.24	1.99	1.55	-	
TE 2	CX		2.12	2.30	2.45	2.55	2.57	2.47	2.22	1.74	-	
TE 2	C0		3.87	4.12	4.29	4.36	4.29	4.02	3.50	2.66	-	
TE 2	01		6.10	6.53	6.85	6.99	6.89	6.47	5.65	4.31	-	
TE 2	02		9.90	10.9	11.8	12.4	12.5	12.1	10.8	8.45	-	
TE 2	03		14.0	15.4	16.7	17.5	17.8	17.1	15.2	12.0	-	
TE 2	CZ	5	1.49	1.62	1.74	1.83	1.87	1.85	1.74	1.51	1.16	
TE 2	CY		1.99	2.17	2.33	2.46	2.52	2.50	2.37	2.09	1.61	
TE 2	CX		2.14	2.34	2.53	2.67	2.76	2.76	2.63	2.35	1.83	
TE 2	C0		3.91	4.20	4.43	4.58	4.61	4.49	4.17	3.59	2.69	
TE 2	01		6.16	6.65	7.06	7.33	7.41	7.24	6.73	5.80	4.36	
TE 2	02		9.98	11.1	12.1	13.0	13.6	13.6	12.9	11.3	8.79	
TE 2	03		14.1	15.7	17.2	18.5	19.3	19.3	18.3	16.0	12.5	
TE 2	CX	10	1.49	1.63	1.76	1.87	1.95	1.98	1.93	1.79	1.54	
TE 2	CY		1.99	2.18	2.36	2.51	2.62	2.67	2.63	2.46	2.15	
TE 2	CZ		2.13	2.35	2.55	2.73	2.86	2.93	2.91	2.77	2.45	
TE 2	C0		3.90	4.22	4.48	4.68	4.80	4.79	4.62	4.24	3.6	
TE 2	01		6.14	6.67	7.13	7.49	7.70	7.72	7.46	6.86	5.8	
TE 2	02		9.93	11.1	12.2	13.3	14.2	14.7	14.5	13.5	11.7	
TE 2	03		14.1	15.7	17.4	18.9	20.1	20.8	20.5	19.1	16.6	
TE 2	CX	15	1.47	1.61	1.74	1.87	1.97	2.03	2.04	1.97	1.80	
TE 2	CY		1.96	2.15	2.34	2.51	2.65	2.74	2.76	2.69	2.50	
TE 2	CZ		2.10	2.31	2.52	2.72	2.89	3.01	3.06	3.02	2.85	
TE 2	C0		3.84	4.17	4.45	4.68	4.85	4.92	4.86	4.64	4.20	
TE 2	01		6.03	6.57	7.06	7.47	7.77	7.92	7.86	7.51	6.81	
TE 2	02		9.75	10.9	12.1	13.3	14.4	15.1	15.4	14.9	13.7	
TE 2	03		13.8	15.4	17.2	18.9	20.4	21.4	21.8	21.1	19.4	

Table 22: Subcooling correction factor 'fsub'

Subcooling [K]	0	2	10	15	20	25
Correction factor	0.97	1.00	1.13	1.20	1.28	1.35

Table 23: Distributer correction factor 'fp' \*

Pressure drop [bar]	Evaporating [°C]									
	-40	-35	-30	-25	-20	-15	-10	5	0	
0	0	1	1	1	1	1	1	1	1	
1	0.99	0.98	0.98	0.98	0.98	0.98	0.97	0.97	0.95	
1.5	0.98	0.98	0.98	0.97	0.97	0.97	0.96	0.95	0.92	
2	0.97	0.97	0.97	0.96	0.96	0.95	0.94	0.93	0.90	

\*calculated at 10°C condensing temperature



Thermostatic expansion valve, type TE 2 for R744, CO2

Table 24: Capacity in TR, useful superheat sh= 3.6 °F (US Units)

Valve type	Orifice no.	Cond. Temp. [°C]	Evaporating [°F]							
			-40	-30	-20	-10	0	10	20	30
			Capacity [TR]							
TE 2	CZ	20	0.40	0.42	0.44	0.43	0.39	0.31	-	-
TE 2	CY		0.53	0.57	0.59	0.58	0.53	0.42	-	-
TE 2	CX		0.57	0.61	0.63	0.63	0.58	0.47	-	-
TE 2	C0		1.04	1.09	1.10	1.07	0.96	0.75	-	-
TE 2	01		1.64	1.73	1.77	1.71	1.54	1.20	-	-
TE 2	02		2.67	2.90	3.05	3.05	2.82	2.27	-	-
TE 2	03		3.78	4.11	4.32	4.32	3.99	3.22	-	-
TE 2	CZ	30	0.41	0.44	0.47	0.48	0.46	0.42	0.32	-
TE 2	CY		0.55	0.60	0.63	0.65	0.63	0.57	0.45	-
TE 2	CX		0.59	0.64	0.68	0.70	0.69	0.63	0.50	-
TE 2	C0		1.07	1.15	1.19	1.19	1.14	1.01	0.77	-
TE 2	01		1.69	1.82	1.90	1.91	1.83	1.62	1.25	-
TE 2	02		2.75	3.04	3.29	3.42	3.37	3.06	2.42	-
TE 2	03		3.90	4.31	4.66	4.85	4.77	4.33	3.42	-
TE 2	CZ	40	0.41	0.45	0.49	0.51	0.52	0.49	0.44	0.33
TE 2	CY		0.55	0.61	0.66	0.69	0.70	0.67	0.60	0.46
TE 2	CX		0.60	0.66	0.71	0.75	0.76	0.74	0.67	0.53
TE 2	C0		1.09	1.17	1.24	1.27	1.26	1.19	1.04	0.78
TE 2	01		1.71	1.86	1.98	2.04	2.03	1.92	1.68	1.26
TE 2	02		2.77	3.11	3.42	3.67	3.77	3.65	3.25	2.53
TE 2	03		3.93	4.41	4.85	5.20	5.34	5.17	4.60	3.58
TE 2	CX	50	0.41	0.45	0.49	0.53	0.55	0.54	0.51	0.44
TE 2	CY		0.55	0.61	0.66	0.71	0.73	0.74	0.70	0.62
TE 2	CZ		0.59	0.66	0.72	0.77	0.80	0.81	0.78	0.70
TE 2	C0		1.08	1.18	1.26	1.31	1.33	1.31	1.22	1.04
TE 2	01		1.70	1.86	2.00	2.10	2.14	2.11	1.97	1.69
TE 2	02		2.75	3.10	3.46	3.78	4.01	4.05	3.85	3.36
TE 2	03		3.89	4.40	4.90	5.36	5.68	5.74	5.45	4.77
TE 2	CX	60	0.40	0.45	0.49	0.52	0.55	0.56	0.55	0.51
TE 2	CY		0.54	0.60	0.65	0.70	0.74	0.76	0.75	0.71
TE 2	CZ		0.58	0.64	0.71	0.76	0.81	0.84	0.84	0.81
TE 2	C0		1.05	1.15	1.24	1.30	1.35	1.35	1.31	1.20
TE 2	01		1.66	1.82	1.97	2.08	2.16	2.18	2.12	1.94
TE 2	02		2.67	3.03	3.40	3.76	4.06	4.23	4.19	3.90
TE 2	03		3.79	4.29	4.82	5.33	5.76	6.00	5.94	5.53

Table 25: Subcooling correction factor 'fsub'

Subcooling [F]	1	5	10	20	30	4
Correction factor	1.00	1.03	1.08	1.17	1.25	1.34

Table 26: Distributer correction factor 'fp' \*

Pressure drop [bar]		Evaporating [°F]							
		-40	-30	-20	-10	0	10	20	30
Pressure drop [psi]	0	1	1	1	1	1	1	1	1
	15	1.00	1.00	1.00	1.00	1.00	1.00	0.99	0.99
	25	1.00	1.00	1.00	0.99	0.99	0.99	0.99	0.99
	30	1.00	0.99	0.99	0.99	0.99	0.99	0.99	0.98

\*calculated at 50°F condensing temperature

## Certificates, declarations, and approvals

The list contains all certificates, declarations, and approvals for the product. Individual code number may have some or all of these approvals, and certain local approvals may not appear on the list.

Some approvals may change over time. You can check the most current status at [danfoss.com](https://danfoss.com) or contact your local Danfoss representative if you have any questions.

**Table 27: Certificates, declarations, and approvals**

File name	Document type	Document topic	Approval authority
EAC RU Д-ДК.БЛ08.В.00191_18	EAC Declaration	Machinery & Equipment	EAC
Danfoss 068U9615.06	Manufacturers Declaration	PED/RoHS	Danfoss
UA.089.D.00188-17	UA Declaration	PED	LLC CDC EURO TYSK
UA.TR-089.0993-17	Pressure - Safety Certificate	PED	LLC CDC EURO TYSK
Danfoss 068U9616.01	Manufacturers Declaration	China RoHS	Danfoss
SA 7200	Mechanical - Safety Certificate	UL	UL

## Online support

Danfoss offers a wide range of support along with our products, including digital product information, software, mobile apps, and expert guidance. See the possibilities below.

### The Danfoss Product Store



The Danfoss Product Store is your one-stop shop for everything product related—no matter where you are in the world or what area of the cooling industry you work in. Get quick access to essential information like product specs, code numbers, technical documentation, certifications, accessories, and more.

Start browsing at [store.danfoss.com](https://store.danfoss.com).

### Find technical documentation



Find the technical documentation you need to get your project up and running. Get direct access to our official collection of data sheets, certificates and declarations, manuals and guides, 3D models and drawings, case stories, brochures, and much more.

Start searching now at [www.danfoss.com/en/service-and-support/documentation](https://www.danfoss.com/en/service-and-support/documentation).

### Danfoss Learning



Danfoss Learning is a free online learning platform. It features courses and materials specifically designed to help engineers, installers, service technicians, and wholesalers better understand the products, applications, industry topics, and trends that will help you do your job better.

Create your Danfoss Learning account for free at [www.danfoss.com/en/service-and-support/learning](https://www.danfoss.com/en/service-and-support/learning).

### Get local information and support



Local Danfoss websites are the main sources for help and information about our company and products. Find product availability, get the latest regional news, or connect with a nearby expert—all in your own language.

Find your local Danfoss website here: [www.danfoss.com/en/choose-region](https://www.danfoss.com/en/choose-region).

---

#### Danfoss A/S

Climate Solutions • [danfoss.com](https://danfoss.com) • +45 7488 2222

Any information, including, but not limited to information on selection of product, its application or use, product design, weight, dimensions, capacity or any other technical data in product manuals, catalogues descriptions, advertisements, etc. and whether made available in writing, orally, electronically, online or via download, shall be considered informative, and is only binding if and to the extent, explicit reference is made in a quotation or order confirmation. Danfoss cannot accept any responsibility for possible errors in catalogues, brochures, videos and other material. Danfoss reserves the right to alter its products without notice. This also applies to products ordered but not delivered provided that such alterations can be made without changes to form, fit or function of the product.

All trademarks in this material are property of Danfoss A/S or Danfoss group companies. Danfoss and the Danfoss logo are trademarks of Danfoss A/S. All rights reserved.