



Compressor  
Voltage Code : FZ

# AE4450Y-FZ1C

High Temp. Commercial (HP)

220 - 240V 1~ 50 Hz

R134a

AE4450Y-FZ1C\_BR

Conditions	Frequency	Nominal Cooling Capacity		Sound Power ISO3745 / ISO 3743-1
		Watts	BTU/h	
EN12900 / R134a	50 Hz	1180	4022	56 dBA

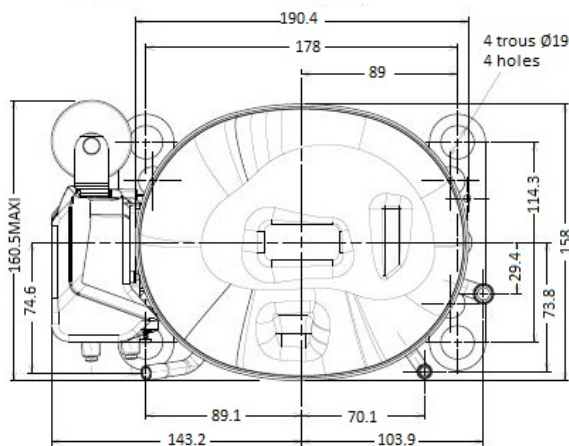
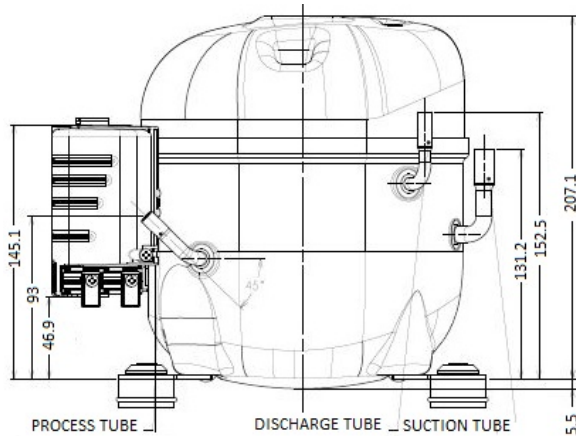

\* EN12900 : T°Cond. 50.0°C / T°Evap. 5.0°C / T°Return gas temp.. 20.0°C  
T°Subcooling. 0.0K

Certificates :



<b>Displacement (cc)</b>	13.24
<b>Net Weight (Kg)</b>	11.7
<b>Oil Quantity (cc)</b>	380.0
<b>Oil Type</b>	Polyolester
<b>Expansion Device</b>	Capillary_Tube/Expansion_Valve
<b>Cooling</b>	Fan
<b>Main Winding (Ohm)</b>	4.8
<b>Start Winding (Ohm)</b>	18.2
<b>Current</b>	
RLA (A)	3.2
LRA (A)	17
<b>Electrical Equipment</b>	CSIR
<b>Overload</b>	T0616
Time Check	2.8s - 5.2s / 18 A
Open Temp	130° C
Close Temp	61° C
<b>Start Capacitor</b>	88 µF / 250 V
<b>Current Relay</b>	MTRP0012
Pick Up	8,5A
Drop Out	7,15A
<b>Refrigerating connection for OD</b>	
Suction Tube	9.5 (3/8")
Discharge Tube	6.35 (1/4")
Process Tube	6.35 (1/4")

Note : Tecumseh reserves the right to change information contained in this document without notification.



**Tecumseh**

<b>AE4450Y-FZ1C</b>	<b>Tension FZ : 220 - 240V 1~ 50 Hz</b>
---------------------	---

Les performances sont données dans les <b>conditions EN12900</b> :	Gaz aspirés :	20.0 °C
Condition Dew	Sous refroidissement :	0.0 K
The performance data are in <b>EN12900 conditions</b> :	Return gas :	20.0 °C
Dew Condition	Subcooling :	0.0 K

<b>50 Hz R134a</b>											
											<b>N°3079</b>
4   T condensation	5   T évaporation	(°C)	<b>-25</b>	<b>-20</b>	<b>-15</b>	<b>-10</b>	<b>-5</b>	<b>0</b>	<b>5</b>	<b>10</b>	<b>15</b>
<b>30</b>	1   P frigorifique	(Watt)	386	510	656	828	1032	1269	1546	1864	2229
	2   P absorbée	(W)	241	271	299	326	353	381	412	447	487
	3   I absorbée	(A)	2.19	2.26	2.33	2.41	2.49	2.59	2.68	2.79	2.90
<b>40</b>	1   P frigorifique	(Watt)	322	437	569	725	907	1119	1365	1650	1976
	2   P absorbée	(W)	244	285	322	356	390	424	459	497	538
	3   I absorbée	(A)	2.16	2.26	2.37	2.49	2.61	2.74	2.88	3.02	3.17
<b>50</b>	1   P frigorifique	(Watt)		364	482	619	779	964	1180	1429	1716
	2   P absorbée	(W)		288	337	382	426	468	510	554	600
	3   I absorbée	(A)		2.26	2.41	2.57	2.73	2.90	3.07	3.25	3.44
<b>60</b>	1   P frigorifique	(Watt)			398	516	652	810	993	1206	1453
	2   P absorbée	(W)			341	401	457	510	563	616	670
	3   I absorbée	(A)			2.45	2.65	2.85	3.05	3.27	3.48	3.71

© 2019 Tecumseh Products Company  
All rights reserved

1 = cooling capacity 2 = power input 3 = current 4 = condensing temperature 5 = evaporating temperature

**Nota : Tecumseh se réserve le droit de modifier les informations contenues dans ce document sans préavis.**  
**Note : Tecumseh reserves the right to change information contained in this document without notification.**