



# Tecumseh

Condensing unit  
Voltage Code : FZ

# AET4450ZHR-FZ

High Temp. Commercial (HP)

220 - 240V 1~ 50 Hz

R452A / R404A / R448A / R449A

AET4450ZHR-FZ

Conditions	Frequency	Nominal Cooling Capacity		Sound Power ISO3745 / ISO 3743-1
		Watts	BTU/h	
EN13215 / R452A	50 Hz	713	2431	69 dBA
EN13215 / R404A	50 Hz	746	2544	69 dBA
EN13215 / R448A	50 Hz	659	2246	69 dBA
EN13215 / R449A	50 Hz	659	2247	69 dBA

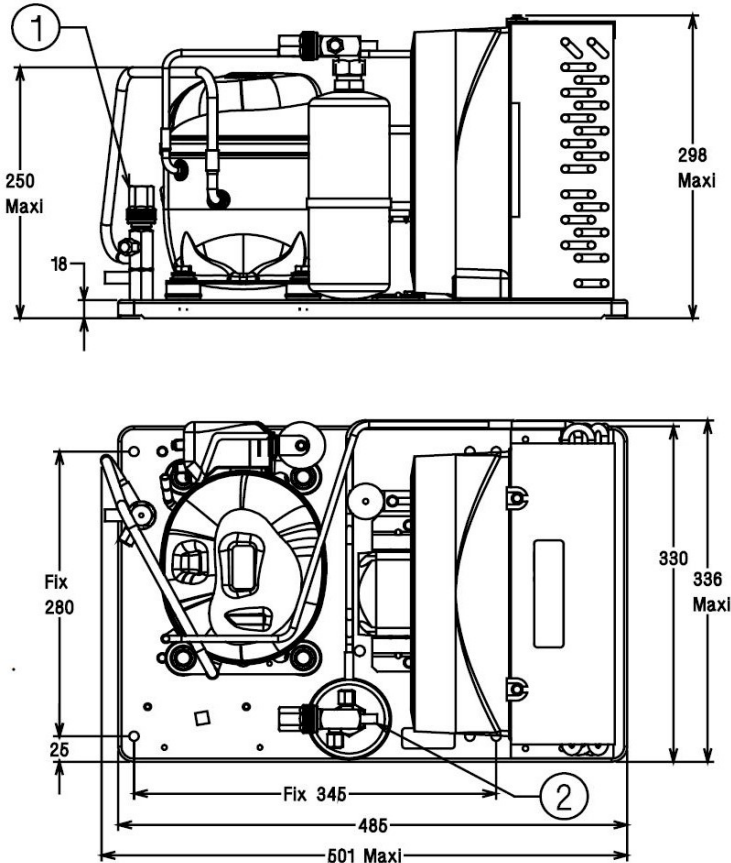

<b>Net Weight (Kg)</b>	24.9
<b>Expansion device</b>	Expansion_Valve
<b>Air Flow (m³/h)</b>	500
<b>Compo Data Sheet</b>	223GS-FZ
<b>Elec Comp Type</b>	CSIR
<b>Current (Amp)</b>	
Load Rated Amp	3.8
Max Cont Current	5.5
Lock Rotor Amp	18.4
<b>Fan</b>	
Speed (rpm)	1300 / 1500
Power (W)	16.0
Diameter (mm)	250
Protection	Overload
IP Level	IP42
<b>Condenser</b>	250/2300
<b>Liquid Receiver</b>	
Capacity (L)	0.75
Maximum Pressure (Bars)	32.0
<b>Suction Line</b>	
Suction Type	Vanne de Socle
For Tubing Out Diam	9.5 (3/8")
Suction Connection Type	Brased
<b>Liquid Line</b>	
Liquid Line Type	Vanne de Socle
For Tubing Out Diam	6.35 (1/4")
Liquid Connecton Type	Brased
<b>Connection Type</b>	VR
<b>Fan Guard</b>	maille < à 8mm

\* EN13215 : T°Ambient 32.0°C / T°Evap. -10.0°C / T°Return gas temp.. 20.0°C  
T°Subcooling. 3.0K

Note : Tecumseh reserves the right to change information contained in this document without notification.



**Tecumseh**

<b>AET4450ZHR-FZ</b>	<b>Tension FZ : 220 - 240V 1~ 50 Hz</b>
----------------------	---

Les performances sont données dans les <b>conditions EN13215</b> :	Gaz aspirés :	20.0 °C
Condition Dew	Sous refroidissement :	3.0 K
The performance data are in <b>EN13215 conditions</b> :	Return gas :	20.0 °C
Dew Condition	Subcooling :	3.0 K

<b>50 Hz R452A</b>											
											<b>N°6669</b>
5   T ambience	6   T évaporation	(°C)	<b>-25</b>	<b>-20</b>	<b>-15</b>	<b>-10</b>	<b>-5</b>	<b>0</b>	<b>5</b>	<b>10</b>	<b>15</b>
<b>25</b>	1   P frigorifique	(Watt)	428	538	661	797	944	1099	1261	1427	1595
	2   P absorbée	(W)	347	387	427	468	510	554	602	653	710
	3   I absorbée	(A)	2.62	2.74	2.87	3.01	3.17	3.35	3.55	3.76	4.01
	4   Tc	(°C)	29.3	31.6	33.9	36.4	38.9	41.5	44.2	47.0	49.9
<b>32</b>	1   P frigorifique	(Watt)		475	589	713	845	983	1127	1274	1425
	2   P absorbée	(W)		396	441	488	535	585	638	695	757
	3   I absorbée	(A)		2.75	2.91	3.08	3.26	3.47	3.68	3.92	4.18
	4   Tc	(°C)		38.0	40.1	42.3	44.6	47.0	49.5	52.1	54.8
<b>43</b>	1   P frigorifique	(Watt)			472	577	687	801	918	1041	
	2   P absorbée	(W)			459	516	574	634	697	763	
	3   I absorbée	(A)			2.96	3.18	3.41	3.64	3.90	4.17	
	4   Tc	(°C)			49.8	51.7	53.7	55.8	57.9	60.2	

<b>50 Hz R404A</b>											
											<b>N°6655</b>
5   T ambience	6   T évaporation	(°C)	<b>-25</b>	<b>-20</b>	<b>-15</b>	<b>-10</b>	<b>-5</b>	<b>0</b>	<b>5</b>	<b>10</b>	<b>15</b>
<b>25</b>	1   P frigorifique	(Watt)	465	576	701	836	980	1130	1284	1437	1588
	2   P absorbée	(W)	364	404	445	485	527	570	616	665	719
	3   I absorbée	(A)	2.76	2.87	3.00	3.13	3.29	3.45	3.64	3.84	4.07
	4   Tc	(°C)	31.9	34.2	36.5	39.0	41.5	44.1	46.8	49.6	52.5
<b>32</b>	1   P frigorifique	(Watt)		509	624	746	874	1005	1139	1271	1401
	2   P absorbée	(W)		415	461	507	554	603	654	708	766
	3   I absorbée	(A)		2.89	3.04	3.21	3.38	3.58	3.78	4.00	4.25
	4   Tc	(°C)		40.6	42.7	44.9	47.2	49.6	52.1	54.7	57.4
<b>43</b>	1   P frigorifique	(Watt)			498	600	704	807	911	1012	
	2   P absorbée	(W)			482	539	596	654	715	778	
	3   I absorbée	(A)			3.12	3.32	3.54	3.77	4.01	4.26	
	4   Tc	(°C)			52.4	54.3	56.3	58.4	60.5	62.8	

**1 = cooling capacity 2 = power input 3 = current 4 = condensing temperature 5 = ambient temperature 6 = evaporating temperature**

**Nota : Tecumseh se réserve le droit de modifier les informations contenues dans ce document sans préavis.**

**Note : Tecumseh reserves the right to change information contained in this document without notification.**

© 2019 Tecumseh Products Company  
All rights reserved



**Tecumseh**

<b>AET4450ZHR-FZ</b>	<b>Tension FZ : 220 - 240V 1~ 50 Hz</b>
----------------------	---

Les performances sont données dans les <b>conditions EN13215</b> :	Gaz aspirés :	20.0 °C
Condition Dew	Sous refroidissement :	3.0 K
The performance data are in <b>EN13215 conditions</b> :	Return gas :	20.0 °C
Dew Condition	Subcooling :	3.0 K

<b>50 Hz R448A (*)</b>											
											<b>N°7032</b>
5   T ambience	6   T évaporation	(°C)	<b>-25</b>	<b>-20</b>	<b>-15</b>	<b>-10</b>	<b>-5</b>	<b>0</b>	<b>5</b>	<b>10</b>	<b>15</b>
<b>25</b>	1   P frigorifique	(Watt)	360	470	595	734	886	1051	1226	1410	1598
	2   P absorbée	(W)	330	369	407	447	488	531	579	631	689
	3   I absorbée	(A)	2.48	2.60	2.73	2.87	3.03	3.21	3.41	3.63	3.88
	4   Tc	(°C)	30.2	32.1	34.1	36.4	38.7	41.3	44.1	47.0	50.2
<b>32</b>	1   P frigorifique	(Watt)		414	531	659	798	948	1108	1275	1447
	2   P absorbée	(W)		377	422	467	514	563	616	674	738
	3   I absorbée	(A)		2.61	2.77	2.94	3.13	3.33	3.56	3.80	4.07
	4   Tc	(°C)		38.6	40.5	42.6	44.8	47.1	49.7	52.4	55.3
<b>43</b>	1   P frigorifique	(Watt)				540	660	788			
	2   P absorbée	(W)				496	554	614			
	3   I absorbée	(A)				3.05	3.28	3.53			
	4   Tc	(°C)				52.3	54.2	56.3			

<b>50 Hz R449A (*)</b>											
											<b>N°6800</b>
5   T ambience	6   T évaporation	(°C)	<b>-25</b>	<b>-20</b>	<b>-15</b>	<b>-10</b>	<b>-5</b>	<b>0</b>	<b>5</b>	<b>10</b>	<b>15</b>
<b>25</b>	1   P frigorifique	(Watt)	360	470	595	734	887	1051	1227	1410	1599
	2   P absorbée	(W)	330	369	407	447	488	531	579	631	689
	3   I absorbée	(A)	2.48	2.60	2.73	2.87	3.03	3.21	3.41	3.63	3.88
	4   Tc	(°C)	30.2	32.1	34.1	36.4	38.7	41.3	44.0	47.0	50.1
<b>32</b>	1   P frigorifique	(Watt)		414	531	659	799	949	1108	1275	1448
	2   P absorbée	(W)		377	422	467	514	563	616	674	738
	3   I absorbée	(A)		2.61	2.77	2.94	3.13	3.33	3.56	3.80	4.07
	4   Tc	(°C)		38.6	40.5	42.5	44.7	47.1	49.6	52.3	55.2
<b>43</b>	1   P frigorifique	(Watt)				540	661	789			
	2   P absorbée	(W)				496	554	614			
	3   I absorbée	(A)				3.05	3.28	3.53			
	4   Tc	(°C)				52.3	54.2	56.2			

**1 = cooling capacity 2 = power input 3 = current 4 = condensing temperature 5 = ambient temperature 6 = evaporating temperature**

(\*) Veuillez vous référer strictement aux Recommandations d'Utilisation et Bulletins Marketing Tecumseh du fait de la température de reflux élevée pour les applications LBP.  
 (\*) Due to very high discharge temperature especially on LBP conditions, please strictly refer to Tecumseh Guidelines & Marketing Bulletin when using this refrigerant.

**Nota : Tecumseh se réserve le droit de modifier les informations contenues dans ce document sans préavis.**

**Note : Tecumseh reserves the right to change information contained in this document without notification.**

© 2019 Tecumseh Products Company  
All rights reserved