



Condensing unit
Voltage Code : FZ

AET4460ZHR-FZ

High Temp. Commercial (HP)

220 - 240V 1~ 50 Hz

R452A / R404A / R448A / R449A

AET4460ZHR-FZ

Conditions	Frequency	Nominal Cooling Capacity		Sound Power ISO3745 / ISO 3743-1
		Watts	BTU/h	
EN13215 / R452A	50 Hz	933	3180	69 dBA
EN13215 / R404A	50 Hz	976	3328	69 dBA
EN13215 / R448A	50 Hz	848	2893	69 dBA
EN13215 / R449A	50 Hz	849	2895	69 dBA

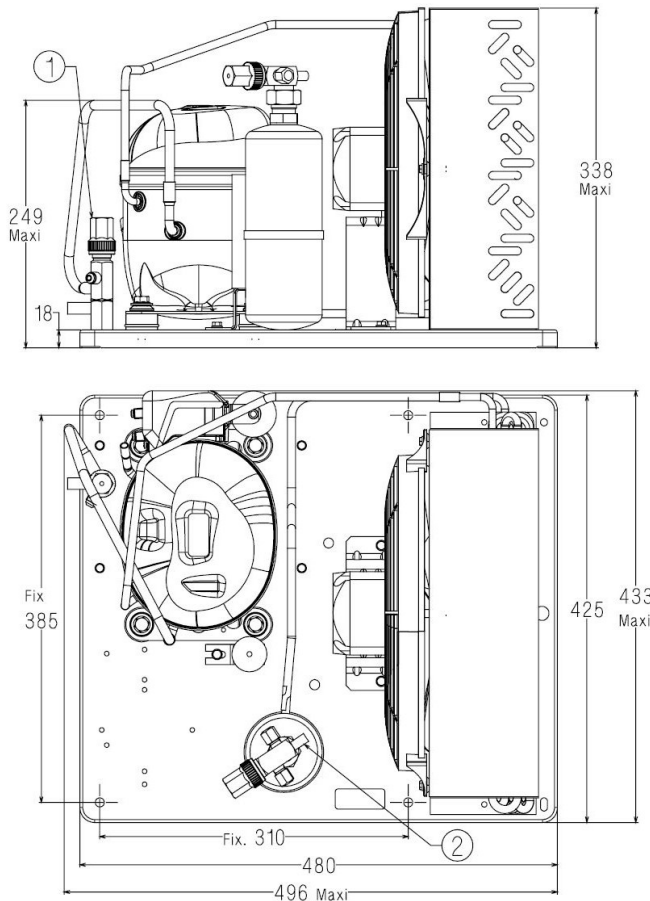

* EN13215 : T°Ambient 32.0°C / T°Evap. -10.0°C / T°Return gas temp.. 20.0°C
T°Subcooling. 3.0K

Net Weight (Kg)	24.8
Expansion device	Expansion_Valve
Air Flow (m³/h)	1130
Compo Data Sheet	223JS-FZ
Elec Comp Type	CSIR
Current (Amp)	
Load Rated Amp	4.9
Max Cont Current	6.5
Lock Rotor Amp	20.2
Fan	
Speed (rpm)	1300 / 1500
Power (W)	25.0
Diameter (mm)	300
Protection	Overload
IP Level	IP42
Condenser	M300/3000
Liquid Receiver	
Capacity (L)	0.75
Maximum Pressure (Bars)	32.0
Suction Line	
Suction Type	Vanne de Socle
For Tubing Out Diam	9.5 (3/8")
Suction Connection Type	Brased
Liquid Line	
Liquid Line Type	Vanne Orientable
For Tubing Out Diam	6.35 (1/4")
Liquid Connecton Type	Brased
Connection Type	VR
Fan Guard	maille < à 8mm

Note : Tecumseh reserves the right to change information contained in this document without notification.



Tecumseh

AET4460ZHR-FZ	Tension FZ : 220 - 240V 1~ 50 Hz
----------------------	---

Les performances sont données dans les conditions EN13215 :	Gaz aspirés :	20.0 °C
Condition Dew	Sous refroidissement :	3.0 K
The performance data are in EN13215 conditions :	Return gas :	20.0 °C
Dew Condition	Subcooling :	3.0 K

50 Hz R452A											
											N°5873
5 T ambience	6 T évaporation	(°C)	-25	-20	-15	-10	-5	0	5	10	15
25	1 P frigorifique	(Watt)	578	712	866	1039	1233	1445	1676	1923	2186
	2 P absorbée	(W)	442	475	511	549	590	635	684	737	795
	3 I absorbée	(A)	3.44	3.56	3.69	3.82	3.97	4.13	4.30	4.50	4.71
	4 Tc	(°C)	26.7	28.2	29.8	31.6	33.5	35.5	37.6	39.8	42.2
32	1 P frigorifique	(Watt)		632	774	933	1107	1297	1503	1723	1957
	2 P absorbée	(W)		496	534	577	623	672	726	785	849
	3 I absorbée	(A)		3.57	3.74	3.90	4.08	4.27	4.48	4.70	4.94
	4 Tc	(°C)		35.2	36.7	38.3	40.0	41.8	43.8	45.9	48.1
43	1 P frigorifique	(Watt)			624	757	901	1057	1224	1403	1595
	2 P absorbée	(W)			573	622	675	733	795	863	936
	3 I absorbée	(A)			3.81	4.04	4.26	4.50	4.75	5.01	5.29
	4 Tc	(°C)			47.7	49.0	50.5	52.0	53.7	55.6	57.5

50 Hz R404A											
											N°523J-FZ
5 T ambience	6 T évaporation	(°C)	-25	-20	-15	-10	-5	0	5	10	15
25	1 P frigorifique	(Watt)	625	760	915	1089	1281	1490	1715	1953	2204
	2 P absorbée	(W)	462	494	530	568	609	653	700	751	807
	3 I absorbée	(A)	3.61	3.73	3.84	3.97	4.11	4.25	4.42	4.59	4.79
	4 Tc	(°C)	29.6	31.1	32.7	34.4	36.3	38.2	40.3	42.4	44.7
32	1 P frigorifique	(Watt)		676	819	976	1148	1334	1532	1743	1963
	2 P absorbée	(W)		517	556	598	643	691	744	800	861
	3 I absorbée	(A)		3.75	3.90	4.06	4.23	4.40	4.59	4.80	5.01
	4 Tc	(°C)		38.0	39.4	41.0	42.6	44.4	46.3	48.3	50.4
43	1 P frigorifique	(Watt)			661	792	932	1082	1240	1406	1582
	2 P absorbée	(W)			599	647	699	755	815	880	949
	3 I absorbée	(A)			4.00	4.21	4.42	4.65	4.88	5.12	5.37
	4 Tc	(°C)			50.0	51.3	52.7	54.2	55.8	57.5	59.3

1 = cooling capacity 2 = power input 3 = current 4 = condensing temperature 5 = ambient temperature 6 = evaporating temperature

Nota : Tecumseh se réserve le droit de modifier les informations contenues dans ce document sans préavis.

Note : Tecumseh reserves the right to change information contained in this document without notification.

© 2020 Tecumseh Products Company
All rights reserved



Tecumseh

AET4460ZHR-FZ	Tension FZ : 220 - 240V 1~ 50 Hz
----------------------	---

Les performances sont données dans les conditions EN13215 :	Gaz aspirés :	20.0 °C
Condition Dew	Sous refroidissement :	3.0 K
The performance data are in EN13215 conditions :	Return gas :	20.0 °C
Dew Condition	Subcooling :	3.0 K

50 Hz R448A (*)											
											N°7033
5 T ambience	6 T évaporation	(°C)	-25	-20	-15	-10	-5	0	5	10	15
25	1 P frigorifique	(Watt)	484	617	769	942	1136	1353	1592	1853	2135
	2 P absorbée	(W)	426	456	490	527	568	612	661	713	772
	3 I absorbée	(A)	3.25	3.37	3.50	3.64	3.80	3.96	4.14	4.34	4.56
	4 Tc	(°C)	28.2	29.5	30.9	32.5	34.2	36.1	38.1	40.3	42.7
32	1 P frigorifique	(Watt)		547	689	848	1027	1225	1444	1682	1941
	2 P absorbée	(W)		477	514	555	601	650	704	763	827
	3 I absorbée	(A)		3.40	3.56	3.73	3.92	4.11	4.32	4.55	4.80
	4 Tc	(°C)		36.5	37.8	39.2	40.8	42.5	44.4	46.4	48.6
43	1 P frigorifique	(Watt)			561	700	853	1023	1210	1414	
	2 P absorbée	(W)			553	602	655	713	777	845	
	3 I absorbée	(A)			3.66	3.88	4.12	4.36	4.62	4.90	
	4 Tc	(°C)			48.7	49.9	51.2	52.6	54.2	55.9	

50 Hz R449A (*)											
											N°6801
5 T ambience	6 T évaporation	(°C)	-25	-20	-15	-10	-5	0	5	10	15
25	1 P frigorifique	(Watt)	484	617	769	942	1137	1354	1593	1854	2136
	2 P absorbée	(W)	426	456	490	527	568	612	661	713	772
	3 I absorbée	(A)	3.25	3.37	3.50	3.64	3.80	3.96	4.14	4.34	4.56
	4 Tc	(°C)	28.2	29.5	30.9	32.5	34.2	36.1	38.1	40.3	42.7
32	1 P frigorifique	(Watt)		547	689	849	1027	1226	1444	1683	1942
	2 P absorbée	(W)		477	514	555	601	650	704	763	827
	3 I absorbée	(A)		3.40	3.56	3.73	3.92	4.11	4.32	4.55	4.80
	4 Tc	(°C)		36.5	37.8	39.2	40.8	42.5	44.4	46.4	48.5
43	1 P frigorifique	(Watt)			561	700	854	1023	1210	1415	
	2 P absorbée	(W)			553	602	655	713	777	845	
	3 I absorbée	(A)			3.66	3.88	4.12	4.36	4.62	4.90	
	4 Tc	(°C)			48.6	49.8	51.1	52.6	54.1	55.9	

1 = cooling capacity 2 = power input 3 = current 4 = condensing temperature 5 = ambient temperature 6 = evaporating temperature

(*) Veuillez vous référer strictement aux Recommandations d'Utilisation et Bulletins Marketing Tecumseh du fait de la température de reflux élevée pour les applications LBP.
 (*) Due to very high discharge temperature especially on LBP conditions, please strictly refer to Tecumseh Guidelines & Marketing Bulletin when using this refrigerant.

Nota : Tecumseh se réserve le droit de modifier les informations contenues dans ce document sans préavis.
Note : Tecumseh reserves the right to change information contained in this document without notification.

© 2020 Tecumseh Products Company
All rights reserved