

Technical Data Sheet

ENGINEERING
TOMORROW



Compressor model **B38G**
Voltage **220-240V 50Hz ~1**
Refrigerant **R134a**

APPLICATION

COMPRESSOR

MOTOR

Application	High Back Pressure	Displacement	3,80 cm ³	Nominal Power	1/8 hp
Refrigerant	R134a	Diameter	19,00 mm	Voltage/Frequency	220-240V 50Hz
Evaporating Temp.	-15,0 °C to 10,0 °C	Stroke	13,40 mm	Voltage range	187-255 V
Expansion	Capillar/Valve	Net Weight	5,00 Kg	Type	CSIR
Comp. Cooling	Static/Fan cooled	Oil type	POE 32	Phase number	1 PH
Max. ambient temp.	43,0 °C	Oil charge	130 cm ³	Locked Rotor Amps (LRA)	4,20 A
Compatible refriger.	R1234yf			Main W. resist. at 25°C	21,50 Ω
				Start W. resist. at 25°C	23,50 Ω

NOMINAL PERFORMANCE

APPROVALS

	ASHRAE	CECOMAF
Cooling Capacity	298 kCal/h	291 W
COP	2,23 W/W	1,91 W/W
EER	1,91 kCal/Wh	1,65 kCal/Wh
Input Power	156 W	152 W
Current	0,98 A	0,96 A

TEST CYCLE CONDITIONS

	ASHRAE HBP (D)	CECOMAF HBP (C)
Evaporating temp. (T _e)	7,2 °C	5,0 °C
Condensing temp. (T _c)	55,0 °C	55,0 °C
Liquid temp. (T _{liq.})	46,0 °C	55,0 °C
Ambient temp. (T _{amb.})	35,0 °C	32,0 °C
Suction temp. (T _{suction})	35,0 °C	32,0 °C
Voltage/Frequency	220 V 50 Hz	220 V 50 Hz

ELECTRICAL COMPONENTS

Starting capacitor	61 µF 330 V			
Relay	Option 1			
Reference	QL2-2.80 (008)			
Pick-Up	2.8 A			
Drop-Out	2.4 A			
Protector	Option 1			
Reference	DRB18P61A1 (067)			
Current				
Time check				
Disc temp. (Open/Close)				



ASHRAE

Tc °C	Te °C	Cooling Capacity kCal/h	Consumption W	Current A	COP W/W	EER kCal/Wh
40	-15	140	98	0,82	1,66	1,43
40	-10	181	104	0,83	2,03	1,74
40	-5	229	110	0,84	2,42	2,08
40	0	282	115	0,86	2,84	2,45
40	5	341	121	0,87	3,29	2,83
40	7,2	369	123	0,88	3,50	3,01
40	10	406	125	0,88	3,77	3,24

45	-15	134	101	0,82	1,54	1,33
45	-10	171	109	0,84	1,83	1,58
45	-5	215	116	0,86	2,15	1,85
45	0	264	124	0,88	2,48	2,14
45	5	319	131	0,90	2,84	2,44
45	7,2	345	134	0,91	3,00	2,58
45	10	380	137	0,92	3,22	2,77

50	-15	128	103	0,83	1,44	1,24
50	-10	161	113	0,85	1,66	1,43
50	-5	201	123	0,88	1,90	1,64
50	0	246	132	0,90	2,17	1,87
50	5	297	141	0,93	2,45	2,11
50	7,2	322	145	0,94	2,59	2,22
50	10	354	150	0,96	2,76	2,37

55	-15	122	106	0,84	1,34	1,15
55	-10	151	118	0,86	1,50	1,29
55	-5	187	129	0,89	1,68	1,45
55	0	228	140	0,93	1,89	1,63
55	5	275	151	0,96	2,12	1,82
55	7,2	298	156	0,98	2,23	1,91
55	10	329	162	1,00	2,36	2,03

60	-15	116	109	0,84	1,24	1,07
60	-10	142	122	0,88	1,35	1,16
60	-5	173	136	0,91	1,48	1,28
60	0	210	149	0,95	1,65	1,42
60	5	254	161	0,99	1,83	1,57
60	7,2	274	167	1,01	1,91	1,64
60	10	303	174	1,04	2,03	1,74

65	-15	110	111	0,85	1,15	0,99
65	-10	132	127	0,89	1,21	1,04
65	-5	159	142	0,93	1,30	1,12
65	0	192	157	0,98	1,43	1,23
65	5	232	172	1,03	1,57	1,35
65	7,2	251	178	1,05	1,64	1,41
65	10	277	186	1,08	1,73	1,49

CECOMAF

Tc °C	Te °C	Cooling Capacity W	Consumption W	Current A	COP W/W	EER kCal/Wh
40	-15	150	99	0,82	1,53	1,32
40	-10	195	105	0,83	1,87	1,61
40	-5	247	110	0,85	2,23	1,93
40	0	304	116	0,86	2,62	2,26
40	5	367	121	0,87	3,03	2,62
40	7,2	397	123	0,88	3,22	2,78
40	10	437	126	0,89	3,46	2,99

45	-15	143	101	0,82	1,41	1,22
45	-10	184	109	0,84	1,68	1,45
45	-5	230	117	0,86	1,97	1,70
45	0	283	124	0,88	2,28	1,97
45	5	342	132	0,90	2,60	2,25
45	7,2	370	135	0,91	2,75	2,37
45	10	407	138	0,92	2,94	2,54

50	-15	136	104	0,83	1,31	1,13
50	-10	172	114	0,85	1,51	1,31
50	-5	214	123	0,88	1,73	1,50
50	0	262	133	0,90	1,97	1,71
50	5	316	142	0,93	2,23	1,93
50	7,2	342	146	0,94	2,35	2,03
50	10	377	151	0,96	2,50	2,16

55	-15	129	107	0,84	1,21	1,04
55	-10	160	118	0,87	1,35	1,17
55	-5	198	130	0,90	1,52	1,31
55	0	241	141	0,93	1,71	1,48
55	5	291	152	0,96	1,91	1,65
55	7,2	315	157	0,98	2,01	1,73
55	10	347	163	1,00	2,13	1,84

60	-15	122	109	0,84	1,11	0,96
60	-10	148	123	0,88	1,21	1,04
60	-5	181	136	0,92	1,33	1,15
60	0	220	150	0,96	1,47	1,27
60	5	266	162	1,00	1,64	1,41
60	7,2	287	168	1,02	1,71	1,48
60	10	317	175	1,04	1,81	1,57

65	-15	115	112	0,85	1,02	0,88
65	-10	137	128	0,89	1,07	0,93
65	-5	165	143	0,93	1,15	1,00
65	0	199	158	0,98	1,26	1,09
65	5	240	173	1,03	1,39	1,20
65	7,2	260	179	1,06	1,45	1,25
65	10	287	187	1,09	1,53	1,32

EN12900

X	Cooling Capacity (W)	Consumption (W)	Current (A)	Mass Flow (kg/h)
1	471,9566703673	50,1771475050	0,6562184661	8,0513461795681
2	19,4373974581	-1,9861453697	-0,0071410783	0,36735553555902
3	-4,3029275751	1,7206727696	0,0051740909	-0,03390706790038
4	0,1215499748	-0,0048141340	0,0000381575	0,003703590565544
5	-0,1871901408	0,0781266378	0,0002596196	-0,002094122500542

Equation	$x_1 + x_2Te + x_3Tc + x_4Te^2 + x_5TeTc$
----------	---

COMPRESSOR DIMENSIONS

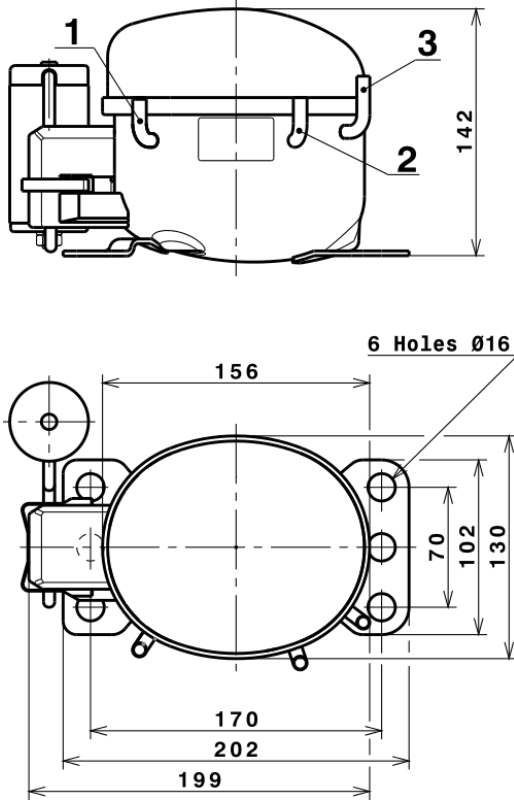

DESIGNATION	INTERNAL DIAM.
1 Suction	6,1 mm
2 Service	6,1 mm
3 Discharge	5,1 mm

WIRING DIAGRAMS AND ELECTRICAL ASSEMBLY

CSIR CONNECTION (B, Small L ranges)

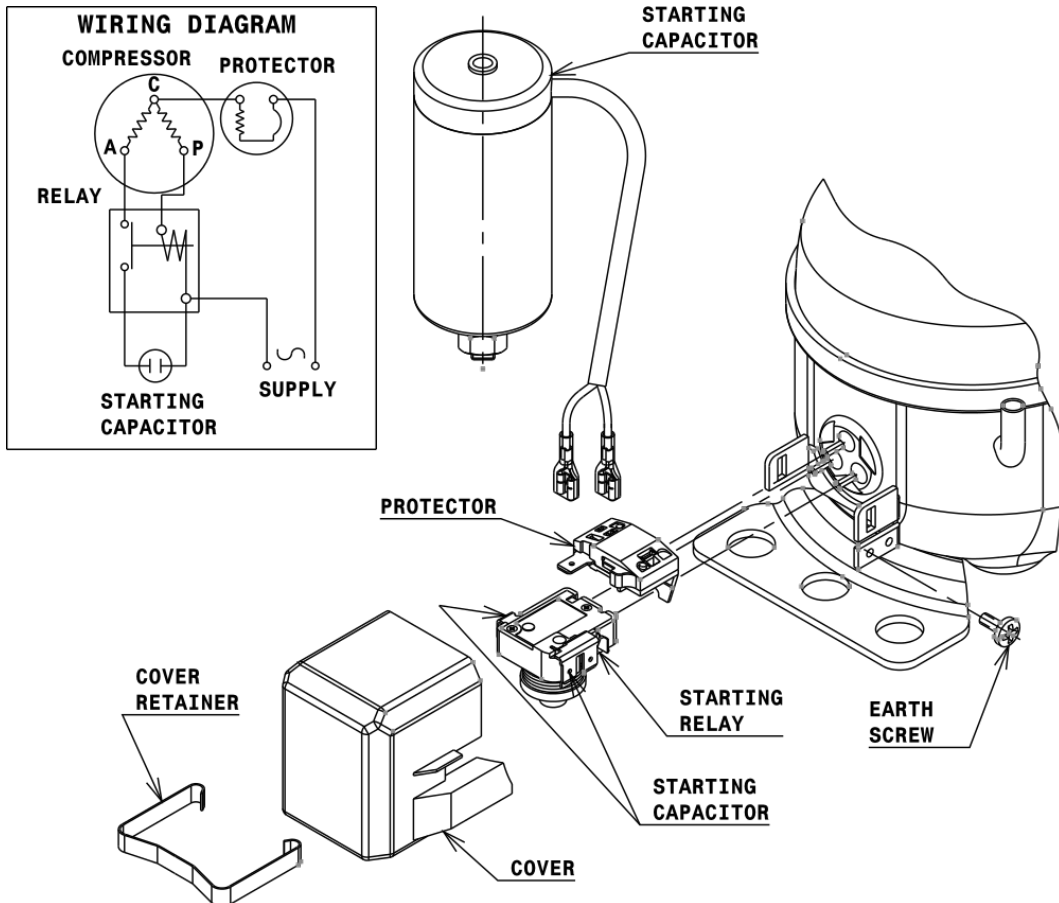

FIXINGS

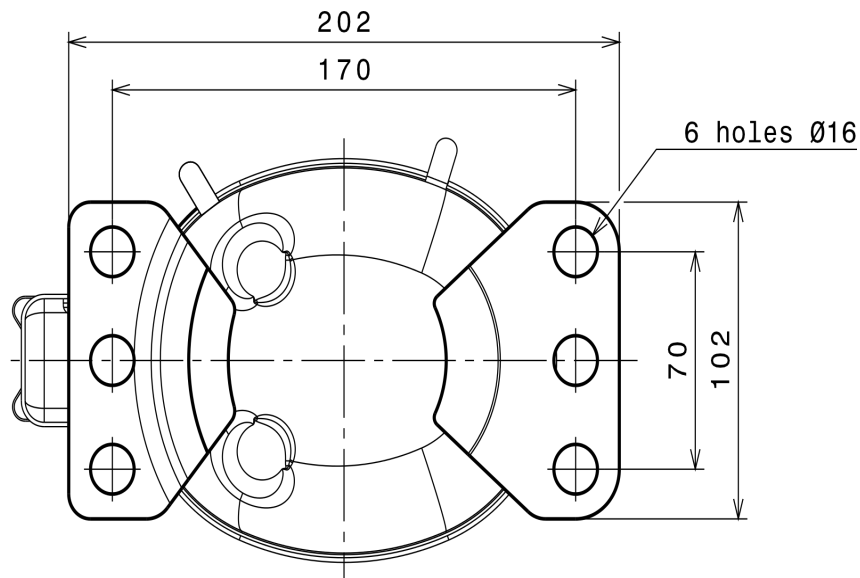

SILENT BLOCKS (MOUNTING ACCESSORIES)

STANDARD

Ø16 holes (170x70 net)



SOA

SOA R134a HBP

