

ENGINEERING  
TOMORROW



# Electromechanical cold controls

for refrigerators and freezers



# Electromechanical cold controls for refrigerators and freezers



## Introduction

Danfoss Appliance Controls with its headquarters, and manufacturing site in Zlaté Moravce-Slovakia, is the oldest and most experienced manufacturer of mechanical thermostats in the world. With over 60 years of experience and more than 340mill produced items, it places Danfoss in a position as the only consecutive player on the current market.

Through extensive product and process development over the last 30 years Danfoss has developed highly automated production facilities ensuring homogeneous products with high quality standards, being considered the bench mark within its business segment.

Danfoss Appliance Controls is best characterized as a stand alone business unit, meaning that the organization has full global business responsibility across regions, no need for multiple contact persons or confirmation steps, we value our customers and are able to set-up the right team to meet their needs.

Application – Function description	page	4 →
Type description	page	7 →
Data – Design	page	12 →
Approvals – ISO certification – Dimensions	page	13 →
Testing – Thermostat selection – Accessories	page	14 →
Range of standard and service thermostats	page	15 →



## Application

Thermostat 077B is used to control the temperature in refrigerators, upright and chest freezers, liquid coolers, bottle coolers and small commercial refrigeration appliances. The thermostat can be used as an evaporator thermostat or a room thermostat.

The thermostats are available with normal function, fixed cut-in and cut-out temperature, constant or variable cut-in temperature for automatic defrost, and with a push button for semi-automatic defrost.

The thermostats can be supplied with the following supplementary functions:

- Auxiliary contact
- Change-over contact
- Signal contact
- Signal contact + series contact
- Signal contact + super freeze-function and indication of same
- Enclosed Brake Device contacts for appliances charged with flammable refrigerants
- Low torque spindle stop turn

All thermostats have NC (Normally closed) main contacts; i.e. they cut out the compressor current circuit on decreasing temperature.

- Cut-out temperature for variable cold controls ranges from 5°-20°C and 0°C for constant ones (range is defined as the interval between cut-out temperature in position cold and warm)
- Differential of normal function thermostat is between 4.5°C and 15°C and from 3°C with fixed setting, all in position warm (*Differential is interval between cut-in and cut-out temperature*).
- Differential of automatic defrost thermostat, with constant or variable cut-in above 0°C is between 10.5°C and 40°C in position warm. (*Differential is interval between cut-in and cut-out temperature*).
- With automatic defrost the cut-out temperature ranges between -5°C and -42°C, the cut-in temperature between +1°C and +11°C.
- Other temperature settings can be supplied by arrangement.
- 6.3x0.8 mm, 4.8x0.8 mm or a combination of above dimensions of terminals.
- Wide range with various extra functions and accessories.
- Approved by recognised authorities.

## Function description

### General

Danfoss 077B thermostats are designed for temperature control in refrigerators and freezers.

The thermostat regulates by cutting off or cutting in current to the compressor. Depending on the temperature registered by the thermostat sensor, the thermostat controls the compressor by powering it (cut-in) or depowering it (cut-off). The thermostat can be used either as an evaporator thermostat or a room thermostat.

"LS" for further details please contact Danfoss. The thermostat body must not be exposed to condensate or defrost water.

### Mounting

To ensure the best function, it is important to ensure that the sensor (capillary tube end) makes good contact with the evaporator; or, in room thermostat applications, with the airflow. The sensor must always be placed colder than the remaining section of the capillary tube and the thermostat itself. To secure trouble-free operation, Danfoss provides the customer with a thermostat drawing (dimension sketch), specifying

among other things the recommended sensor mounting length "LS". For further details, please contact Danfoss. The thermostat body must not be exposed to condensate or defrost water.

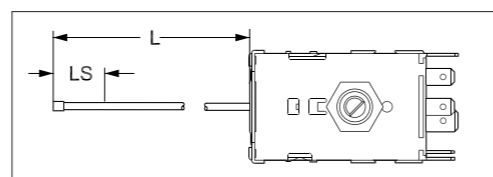

### Operation

On thermostats with a spindle, the temperature is adjusted to cold by turning it clockwise (from warm towards cold position). Both cut-out and cut-in temperatures can be changed by turning the spindle, except on types 077B6, 077B62 and 077B63, where only the cut-out temperature can be changed in this way.

On thermostats without spindle, the temperature is fixed (B025, B045, B24 and B34). The thermostats can be supplied with or without stop. The stop function cuts the main power supply to the heater and, for example, the heating element.

## Function

All normal function thermostats have a cut-out temperature range and a cut-in temperature range.

The differential is defined as the difference between cut-in and cut-out temperatures. However, the temperature settings of fixed function thermostats are non-adjustable.

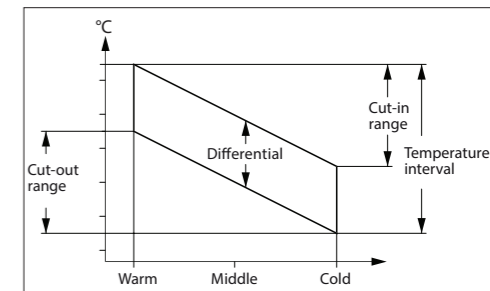

On thermostats with constant cut-in temperature, B6 type, the terms "differential" and "cut-in temperature range" do not apply. The only relevant terms are "cut-out temperature range" and "temperature interval".

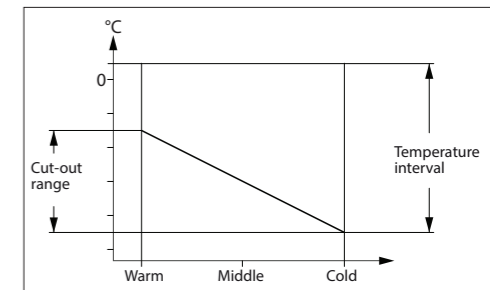

The thermostats can be divided up into the following main types:

1. Thermostat with normal function, type 077B0.
2. Thermostat with signal function, type 077B2/077B3.
3. Thermostat with signal function and series stop contact, type 077B25.
4. Thermostat with contact for indication of super function and signal contact, cutting in on rising temperature, type 077B26.

5. Thermostat with push button defrost and automatic reset, type 077B4.

6. Refrigerator thermostat with automatic defrost and variable cut-in temperature, type 077B5.

7. Refrigerator thermostat with automatic defrost and constant cut-in temperature, type 077B6.

## Danfoss type 077B mechanical cold controls

Main type	Functionality description
B0	Without additional functionality
B02	With auxiliary contact
B025	With fixed settings and changeover contact (reversing switch)
B04	With changeover contact
B045	With fixed settings
B2	With signal contact, cutting in on rising temperature
B24	With fixed settings and signal contact, cutting in on rising temperature
B25	With serial stop contact and signal contact, cutting in on rising temperature
B26	With contact for indication of super function and signal contact, cutting in on rising temperature
B3	With signal contact, cutting out on rising temperature
B34	With fixed settings and signal contact, cutting out on rising temperature
B4	With push button defrost
B5	With large differential and automatic defrost
B52	With large differential, automatic defrost and auxiliary contact
B53	With large differential, automatic defrost and changeover contact
B6	With constant cut-in temperature and automatic defrost
B62	With constant cut-in temperature, automatic defrost and auxiliary contact
B63	With constant cut-in temperature, automatic defrost and changeover contact

The auxiliary contact cuts out when the spindle is turned to position "stop" (θ). The auxiliary contact can be used to cut out a heating element, for example, also in line with the main switch. The contact withstands 6/36A or 8/40A (FLA/LRA).

The signal contact is used to set off an alarm (audible or visual) when the sensor temperature exceeds 3-5°C of the cut-in one. The signal contact withstands a max. load of 0,1 A NI (Resistive).

The reversing switch (changeover contact) is mainly used to control 3/2-way solenoid valves in dual temperature cabinets. The changeover contact withstands a max. load of 0.5 A NI (resistive) or 0.1 A (inductive).

The series contact cuts out when the spindle is turned to position "stop". Both the main and signal contacts are cut out. The series contact withstands a max. load of 6/36 A or 8/40 A (FLA/LRA).

The super function contact cuts in when the spindle is turned to position "super". The compressor runtime is consequently unlimited. The super function contact withstands a max. load of 0.1 A NI (resistive).

Thermostats with fixed settings are assembled without a spindle: the temperature range is not adjustable.

Danfoss B4 type thermostats are used for semi-automatic defrost fridges; a push-button is used to manually activate a singular defrost cycle.

Refrigerator thermostats with a cut-in temperature between +2°C and +11°C are used in automatic defrost systems. The evaporator de-ices during every compressor stop time.

Thermostats with the Danfoss Enclosed Brake Device (EBD) are being assembled inside household appliances charged with flammable refrigerants such as R600a (isobutene) or R290 (propane) to prevent explosions due to leakage.

Thermostats with low torque spindle stop turn meet applications where a reduced turn off torque is required (max. 0.3 Nm at 26°C). The feature is only available in thermostats with serial connected auxiliary contacts. For further details, please contact Danfoss.

### Performance

Danfoss electromechanical cold controls are designed to operate at least 300,000 cycles at full load (6/36 A and 8/40 A, respectively); internal quality audits reinforced product performance by metering over 1,000,000 cycles. Cut-out temperature setting drifts should be anticipated.

Safety backup control (Redundant thermostat) Danfoss electromechanical cold controls are designed for fridges and freezers in household- and light commercial appliances. Within the high-price food sector, Danfoss recommends protecting comestible goods by operating appliances with a built-in safety backup control or Danfoss electronic thermostats.

For more information, please contact Danfoss.

## Type description

Function	Operation mode
	<p><b>Type B0</b> Without extra functionality</p>
	<p><b>Type B02</b> With auxiliary contact</p>
	<p><b>Type B04</b> With changeover contact</p>
	<p><b>Type B02</b> With auxiliary contact</p>

Current marking							
Type	Contact	Europe			USA/Canada		
		V AC	FLA	LRA	V AC	FLA	LRA
<b>B0</b>	3-4	6	(6) A	250 V	240	6	36
<b>B02</b>	3-4	6	(6) A	250 V	240	6	36
	3-6	6	(6) A	250 V	240	6	36
<b>B04</b>	3-4	6	(6) A	250 V	240	6	36
	3-6	0.5	0.1 A	250 V	240	0.5 A	NI

Function	Operation mode
	<p><b>Type B045</b> With fixed setting</p>
	<p><b>Type B025</b> With fixed setting with changeover contact</p>

Current marking							
Type	Contact	Europe			USA/Canada		
		V AC	FLA	LRA	V AC	FLA	LRA
<b>B045</b>	3-4	6	(6) A	250 V	240	6	36
<b>B025</b>	3-4	6	(6) A	250 V	240	6	36
	3-6	0.5	0.1 A	250 V	240	0.5 A	NI

Type description

Function	Operation mode
	<p><b>Type B20</b> With signal contact that cuts in on rising temperature</p>
	<p><b>Type B26</b> With contact for indication of super function and signal contact, cutting in on rising temperature</p>
	<p><b>Type B25</b> With serial stop contact and signal contact, cutting in on rising temperature</p>
	<p><b>Type B3</b> With signal contact, cutting out on rising temperature</p>

Current marking

Type	Contact	Europe			USA/Canada		
		V AC	FLA	LRA	V AC	FLA	LRA
<b>B2</b>	3-4	6	(6) A	250 V	240	6	36
	3-6		0.1A	250 V	240	0.1A	NI
<b>B25</b>	3-4	6	(6) A	250 V	240	6	36
	3-6		0.1 A	250 V	240	0.1 A	NI
	8-3	6	(6) A	250 V	240	6	36
<b>B26</b>	3-4	6	(6) A	250 V	240	6	36
	3-6		0.1 A	250 V	240	0.1 A	NI
	3-8		0.1 A	250 V	240	0.1 A	NI
<b>B3</b>	3-4	6	(6) A	250 V	240	6	36
	3-6		0.1 A	250 V	240	0.1 A	NI

Type description

Function	Operation mode
	<p><b>Type B24</b> With fixed settings and signal contact, cutting in on rising temperature</p>
	<p><b>Type B34</b> Fixed setting with signal contact that cuts out on rising temperature</p>

Current marking

Type	Contact	Europe			USA/Canada		
		V AC	FLA	LRA	V AC	FLA	LRA
<b>B24</b>	3-4	6	(6) A	250 V	240	6	36
	3-6		0.1A	250 V	240	0.1A	NI
<b>B34</b>	3-4	6	(6) A	250 V	240	6	36
	3-6		0.1 A	250 V	240	0.1 A	NI

Function	Operation mode
	<p><b>Type B4</b> With push button defrost</p>

Current marking

Type	Contact	Europe			USA/Canada		
		V AC	FLA	LRA	V AC	FLA	LRA
<b>B4</b>	3-4	6	(6) A	250 V	240	6	36

Type description

Function	Operation mode
	<p><b>Type B5</b> With large differential and defrost</p>
	<p><b>Type B52</b> With large differential, automatic defrost and auxiliary contact</p>
	<p><b>Type B53</b> With large differential, automatic defrost and changeover contact</p>
	<p><b>Type B52</b> With large differential, automatic defrost and auxiliary contact</p>

Current marking

Type	Contact	Europe			USA/Canada		
		V AC	FLA	LRA	V AC	FLA	LRA
<b>B5</b>	3-4	6	(6) A	250 V	240	6	36
<b>B52</b>	3-4	6	(6) A	250 V	240	6	36
	3-6	6	(6) A	250 V	240	6	36
<b>B53</b>	3-4	6	(6) A	250 V	240	6	36
	3-6	0.5	0.1 A	250 V	240	0.5 A	NI

Type description

Function	Operation mode
	<p><b>Type B6</b> With constant cut-in temperature and automatic defrost</p>
	<p><b>Type B62</b> With constant cut-in temperature, automatic defrost and auxiliary contact</p>
	<p><b>Type B63</b> With constant cut-in temperature, automatic defrost and changeover contact</p>
	<p><b>Type B62</b> With constant cut-in temperature, automatic defrost and auxiliary contact</p>

Current marking

Type	Contact	Europe			USA/Canada		
		V AC	FLA	LRA	V AC	FLA	LRA
<b>B6</b>	3-4	6	(6) A	250 V	240	6	36
<b>B62</b>	3-4	6	(6) A	250 V	240	6	36
	3-6	6	(6) A	250 V	240	6	36
<b>B63</b>	3-4	6	(6) A	250 V	240	6	36
	3-6	0.5	0.1 A	250 V	240	0.5 A	NI

Technical data

Temperature interval	-42°C → +11°C
Cut-out temperature range	+5°C → +20°C
Differential	+3°C → +40°C (depending on spindle position and type)
Constant cut-in temperature	+1°C → +11°C (type 077B6 only)
Signal temperature	From +3°C → +5°C higher than cut-in temperature
Barometric pressure	As default 760 mm Hg (1013 hPa), others on demand
Mounting	To be mounted with nut or bracket (clip)
Connection terminal	6.3×0.8 mm, 4.8×0.8 mm, or any combination of both
Capillary tube length	Standard lengths: 0.8 m, 1.0 m, 1.2 m Customized lengths: 0.3 m → 2.9 m PE coated tube: 0.3 m → 2.3 m Longer lengths by arrangement with Danfoss
Ambient temperature	-25°C → +65°C
Humidity	<90% RH (non-condensing)
Weight	For capillary tubes longer than 2.3 m please contact Danfoss

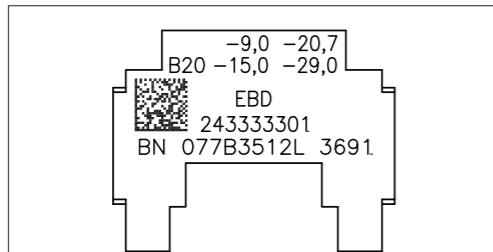

Deviant barometric pressure adjustment can be provided in accordance with customer requirements. An optional PE coating offers capillary tube protection where requested. In case of risking the thermostat body's placement at a colder spot than the sensor tip, an optional built-in heating element can be supplied. The code number is laser printed on the thermostat. If required, the thermostat can

be supplied marked with the customer code number, cut-in and cut-out temperatures in positions "warm" and "cold", as well as data matrix marking.

**The first row** indicates the thermostat's cut-in temperature in positions "warm" and "cold".

**The second row** indicates the Danfoss thermostat type and cut-out temperatures in positions "warm" and "cold".

**The third row** indicates the customer code and data matrix marking (optional) as well as EBD marking (when specified).

**The fourth row** provides the Danfoss process code, code number and production week/year/batch information.

Design details

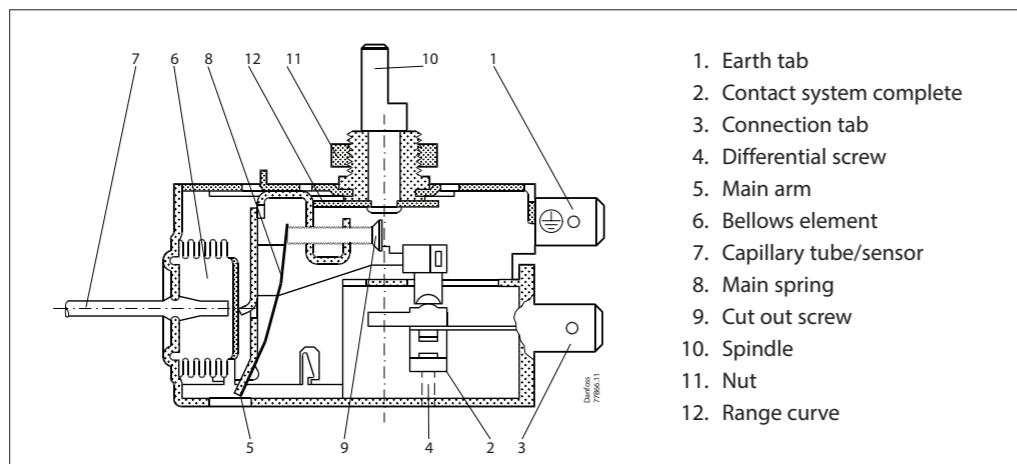

1. Earth tab
2. Contact system complete
3. Connection tab
4. Differential screw
5. Main arm
6. Bellows element
7. Capillary tube/sensor
8. Main spring
9. Cut out screw
10. Spindle
11. Nut
12. Range curve

Approvals – ISO certification - Dimensions

Approvals

Electromechanical cold controls are generally classified as individual components, also when assembled in refrigeration appliances. Hence some regional authorities stipulate cold controls to be subject to an individual approval. All Danfoss electromechanical cold controls are approved by the following authorities:



ISO certification

Danfoss Appliance Controls are certified by Bureau Veritas in ISO14001, ISO9001 and OHSAS18001.



Dimensions

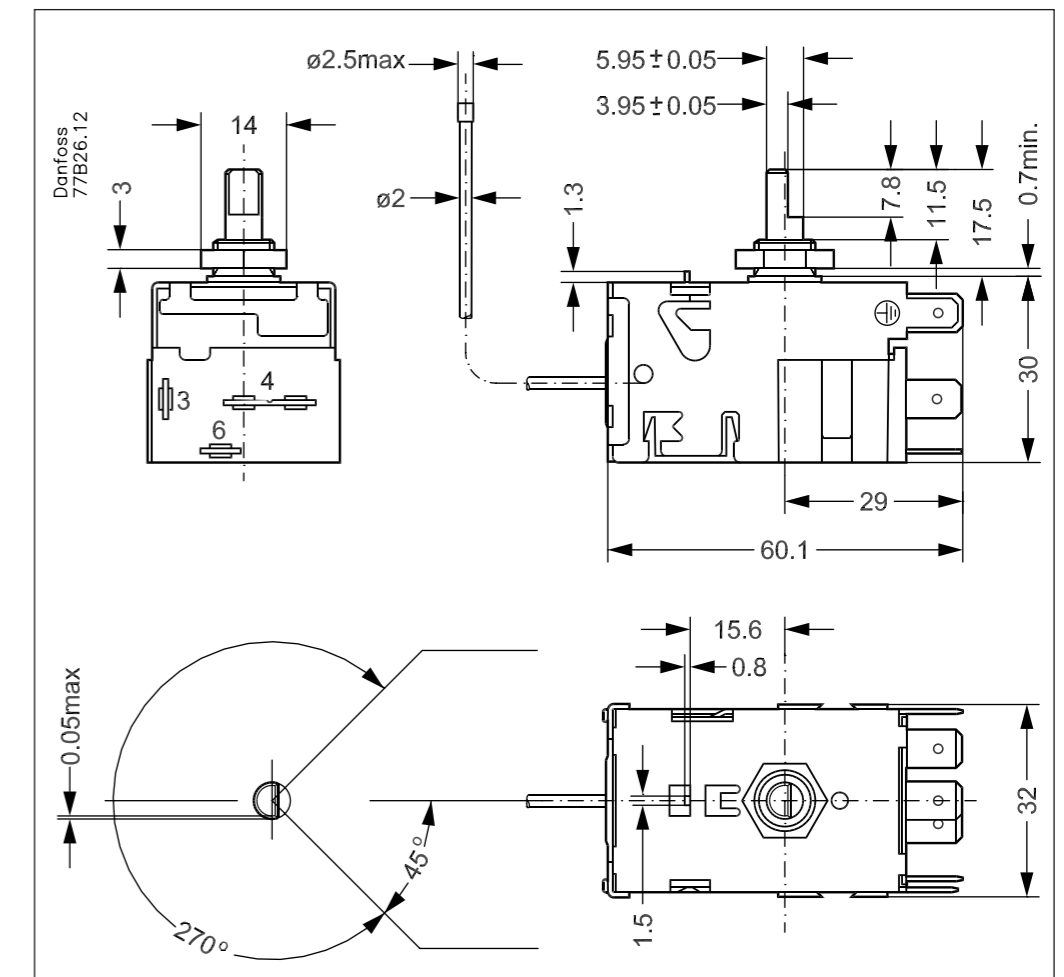



**Testing**

All Danfoss electromechanical cold controls pass multiple hardware and operational tests to ensure that cut-in and cut-out temperatures are properly adjusted. A Danfoss test certificate may be provided free of charge.

To ensure sustained control precision, the submerged part of the sensor (LS) is cooled down/heated up at speed of only 0.5 ±0.1°C /minute. Both cut-in and cut-out temperatures are mapped with the controls closing and opening the main contact respectively. To enhance the performance of the controls, this process is performed twice and only the second reading applies.

When evaluating temperature settings, the barometric pressure discussed above has to be taken into consideration.

**Signal contact adjustment**

The cold control adjustment bath is continuously heated up to a temperature higher than the main contact's cut-in value, until the control cuts-in the signal contact. The first reading of the mapped bath temperature applies.

**Semi-automatic reading**

During the control's adjustment bath, the defrost push-button is pressed throughout if the sensor temperature ranges between the cut-in and cut-out values. The bath is on-ward-heated until the control cuts in. The first reading of the mapped bath temperature applies.

**Thermostat selection**

When selecting a thermostat, the following three factors must be taken into consideration:

- 1.The temperature conditions in the refrigeration appliance
- 2.Pressure equalisation during standstill periods
- 3.Compressor capacity utilisation

Satisfactory conditions can be achieved by observing the following guidelines:

The thermostat range determines the temperature level in the refrigerator or freezer. The range selection has to be consistent with avoidance of short operating times in "warm" position.

With the thermostat in "cold" position, in high ambient temperatures and under high load, the thermostat cut-out function must remain operational. This can be achieved by setting the cut-out temperature about 2°C higher in relation to the temperature that can be reached. In case a permanent compressor run time is required in "cold" position, the cut-out point should be set 2°C colder than the temperature that can be reached.

In general, a cut-out temperature range of 10°C is suitable for most refrigerators and freezers. The differential should exceed a minimum range to secure the refrigeration system's full pressure equalisation; otherwise, the restart of e.g. compressors equipped with LST starting devices may be impeded.

The experience-based Danfoss recommendations given below indicate some appliance-specific minimum differentials in position "warm":

Refrigerators	8-10°C
Chest freezers	8-10°C
Upright freezers	5-7°C
Liquid and bottle coolers	approx. 4°C

In order to find the best cold control variant, multiple appliance tests need to be performed. Danfoss provides its customers with valuable application notes providing, for example, relevant information on sensor and cold control placement. For further information, please contact Danfoss.

**Accessories**

Danfoss offers a wide range of different accessories in various colours, including items like dial plates, washers and knobs. For more information, please contact your local Danfoss dealer.

Application	Temperature °C at 760 mm Hg					Capillary type length	Code number
	Thermostat position			Signal	Defrost		
	Warm Cut-in/ Cut-out	Middle Cut-in/ Cut-out	Cold Cut-in/ Cut-out				
<b>Function Standard Thermostats</b>							
<b>Refrigerators</b>							
Without extra functionality	+3.5/-3*	0/-7	-5.4/-12	-	-	1.0	077B0020
Without extra functionality	-2/-11*	-5.5/-15	-10/-20.5	-	-	1.0	077B0021
Without extra functionality (No. 1)	+2.5/-5*	-	-13.5/-24.5	-	-	1.2	077B0033
<b>Chest and Upright freezers</b>							
Without extra functionality	-15/-23*	-18/-27	-22/-32	-	-	0.8	077B0025
With signal contact, cutting in on rising temperature	-15/-23*	-18/-27	-22/-32	-12*	-	0.8	077B2020
With signal contact, cutting in on rising temperature (No. 6)	-10/-17*	-	-24/-34.7	-6*	-	2.0	077B2077
<b>Two-temperature cabinets with automatic defrost</b>							
With constant cut-in temperature, automatic defrost and auxiliary contact	+3.5/-12.5	+3.5/-17.5	+3.5/-23*	-	-	1.0	077B6021
With constant cut-in temp., automatic defrost and auxiliary contact (No. 3)	+3.5/-11	-	+3.5/-27*	-	-	1.2	077B6208
With constant cut-in temp. and automatic defrost and auxiliary contact	+3.5/-10	+3.5/-15	+3.5/-20*	-	-	1.0	077B6220
With constant cut-in temp., automatic defrost and auxiliary contact (No. 3)	+3.5/-11	-	+3.5/-27*	-	-	2.0	077B6476
With constant cut-in temp., automatic defrost and changeover contact	+5/-10*	-	+5/-30	-	-	1.5	077B6321
<b>Ice cream cabinets and freezers without signal</b>							
Without extra functionality (No. 5)	-7.5/-15*	-	-22/-33.1	-	-	2.0	077B0102
<b>Liquid and Bottle coolers</b>							
Without extra functionality (liquid)	+15.5/+9	+12/+5	+8/+0.5*	-	-	1.2	077B0027
Without extra functionality (bottle)	+10.5/+5	0/-7	+3.0/-4.5*	-	-	1.2	077B0028
Without extra functionality (bottle) (No. 8)	+10.9/+5.2	-	-1/-8.5*	-	-	2.0	077B0155
<b>Absorption coolers</b>							
With auxiliary contact (No. 4)	+3.5/-1*	-2/-7	-7/-12.5	-	-	1.2	077B0220
<b>Function Service Thermostats</b>							
	Thermostat position			Signal	Defrost	Capillary type length	Code number
	Warm Cut-in/ Cut-out	Middle Cut-in/ Cut-out	Cold Cut-in/ Cut-out				
No. 1 Refrigerators	+2/-5.5	-	-13.5/-25*	-	-	1.3	077B7001
No. 2 Refrigerators with pushbutton defrost	0/-7.5*	-	-12/-22	-	+6	1.3	077B7002
No. 3 Refrigerators with automatic defrost	+3.5/-11	-	+3.5/-27.5*	-	-	1.6	077B7003
No. 4 Absorption refrigerators	+3.5/-1*	-	-5/-11	-	-	1.5	077B7004
No. 5 Ice-cream cabinets and freezers without signal	-7.5/-15	-	-21/-32.5*	-	-	2.3	077B7005
No. 6 Freezers with active signal	-10/-17*	-	-24/-34.5	-6*	-	2.3	077B7006
No. 7 Freezers with passive signal	-10/-17*	-	-24/-34.5	-6*	-	2.3	077B7007
No. 8 Bottle and liquid coolers	+11.5/+6*	-	-1/-8.5	-	-	2.0	077B7008

\* Adjustment position



# Electromechanical cold controls for refrigerators and freezers



## Vision

We want to be a significant leading global provider of cold controls and cold control solutions for the appliance industry, and therefore contribute to the success of our customers.

We will be respected in our environment, and among our owners, customers and employees, for what we do, and how we do it.

We will be a highly efficient and lean organization generating maximum profits through economics of scale and sublime quality products.

## Mission

Our Mission is to be the worlds premier provider of cold controls, cold control solutions and services within the business area household and light commercial appliances, offered to the global market of OEMs and wholesalers, in order to fulfil their needs for components, solutions and added value.

**Our competitiveness is based on world class quality, knowledge, customer service and support.**

We will work according to our Citizenship Principles in such a manner to be recognized as the most respected, safe and reliable manufacture of cold controls in the world.

To support our mission, we are guided by our commitment to continuously value enhancement, policies, principles, and beliefs that guide our work every day.