

Data sheet

## Sight glass (Low pressure)

### Types SG, SGN, SGR and SGRN



SG is sight glasses for low pressure application (Max Working Pressure 35 bar / 500 psig).

SG is available with flare, solder and socket connections, and with and without moisture indicators.

SGN and SGRN are equipped with sensitive indicators that reflects a color, which depends on the moisture content in the refrigerant.

SG and SGR, without moisture indicator, are mainly used to indicate the condition of the refrigerant in the liquid line or the flow in the oil return line from the oil separator.

#### Features

##### Type SG / SGR (without indicator)

- Indicates lack of subcooling
- Indicates refrigerant deficiency
- Indicates liquid level in receiver
- Indicates oil level in compressor
- Solder / solder connection or socket type







##### Type SGN / SGRN (with N type indicator)

- Indicates too high moisture content in the refrigeration system by colors
- Indicates lack of subcooling
- Indicates refrigerant deficiency
- Flare / flare, solder / solder connection or socket type

- Conforms to Pressure Equipment Directive 2014/68/EU
- UL approval for selected code numbers
- Large viewing window for better visibility
- Provides accurate identification of system conditions
- Easy to indicate liquid and oil level by float ball of socket type
- Good corrosion resistance by 2000 hours salt spray for brass material according to ASTM B117 requirement

## Sight glass (Low pressure) | Types SG, SGN, SGR and SGRN

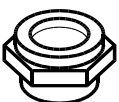
### Available types

<b>Flare Internal x External</b>  SGN with indicator	<b>Solder version ODF x ODF</b>  SG without indicator	
<b>Solder version ODF x ODM</b>  SGN with indicator	<b>Solder version ODF x ODF</b>  SGN with indicator	<b>Flare external x External</b>  SGN with indicator
<b>Socket</b>  SGR without indicator	<b>Socket</b>  SGRN with indicator	<b>Saddle</b>  SGS

### Choice of sight glass moisture indication

Before choosing a sight glass with moisture indicator, the following should be considered:

- type of refrigerant
- water solubility of refrigerant
- the level on which a danger signal is required

Be aware that polyester oil for non-flammable refrigerants, e.g. R134a, R404A, R407C react with water in a hydrolysis generating acid and alcohol.

The recommended levels of moisture content are usually between 30 and 75 ppm, where hermetic compressors only tolerate very low moisture content, while semi-hermetic and other compressors normally tolerate higher moisture contents in the refrigerant.

**!** Note: when storing, transporting or installing the Sight Glass, avoid the chemical indicator to get in contact with non-refrigerant medium or fluid (like water, oil, ect.)

The colour on the sight glass indicator depends on the moisture content of the refrigerant.

The values under “green / dry” are to be considered as perfect condition meaning full protection against harmful effects from moisture. In other words, the filter drier is working perfectly.

If the green color starts to fade, the color change has begun and the indicator should therefore be watched more carefully. If the color changes to yellow it is a clear signal that the capacity of the filter drier is exceeded and must be replaced immediately.

### REACH requirements

All Danfoss products fulfill the requirements in REACH.

One of the obligations in REACH is to inform customers about presence of Candidate list substances if any, we hereby inform you about one substance on the candidate list:

A moisture indicator in a sight glass contains a paper which is impregnated with Cobalt Dichloride (CAS no: 7646-79-9) in a concentration above 0.1% w/w. If the valve has been damaged or dismantled:

- Avoid skin contact with the paper
- Do not inhale the dust from the paper
- The paper must be disposed as hazardous waste

**Technical data**

Media temperature: -50 – 80 °C / -58 – 175 °F  
 Max. working pressure (PS / MWP): 35 bar / 500 psig  
 Refrigerant oil: All mineral oils and ester oils

**SGN / SGRN for R22, R134a, R404A, R407C, R507, R407A, R407F, R448A, R449A, R450A, R452A, R513A**

	Moisture content ppm = parts per million					
	SGN / SGRN					
	Media temperature 25 °C / 77 °F			Media temperature 43 °C / 109 °F		
	Green / dry	Intermed. color	Yellow / wet	Green / dry	Intermed. color	Yellow / wet
R22	< 30	30 – 120	> 120	< 50	50 – 200	> 200
R134a	< 30	30 – 100	> 100	< 45	45 – 170	> 170
R404A	< 20	20 – 70	> 70	< 25	25 – 100	> 100
R407C	< 30	30 – 140	> 140	< 60	60 – 225	> 225
R507	< 15	15 – 60	> 60	< 30	30 – 110	> 110
R407A	< 29	29 – 115	> 115	< 48	48 – 192	> 192
R407F	< 30	30 – 168	> 168	< 60	60 – 240	> 240
R448A	< 28	28 – 110	> 110	< 70	70 – 227	> 227
R449A	< 29	29 – 105	> 105	< 53	53 – 200	> 200
R450A	< 23	23 – 148	> 148	< 46	46 – 245	> 245
R452A	< 20	20 – 79	> 79	< 30	30 – 143	> 143
R513A	< 22	22 – 75	> 75	< 22	22 – 123	> 123

**Notes:**

- For a fully updated list of approved refrigerants, visit <http://store.danfoss.com/> and search for individual code numbers, where refrigerants are listed as part of product details.
- For colours reflecting moisture values of other refrigerants and other media temperature, please contact Danfoss.
- SG with indicator is not suitable for oil application. For detailed information please contact Danfoss.
- For the Max. media temperature which is above 55 °C / 131 °F for socket type with float ball, please consult Danfoss.

**Ordering**
**SG without indicator**

	Type	Connection type	Connection		Code no. Multi pack
			[inch]	[mm]	
	SG 10s	Solder ODF × ODF	3/8	-	014-0037
	SG 22s		7/8	22	014-1207 <sup>3)</sup>

**SGN with N type indicator**

	Type	Connection type	Connection		Code no. Multi pack <sup>4)</sup>
			[inch]	[mm]	
	SGN 6	Flare ext. × ext.	1/4	6	014-0161
	SGN 10		3/8	10	014-0162
	SGN 12		1/2	12	014-0163
	SGN 16		5/8	16	014-0165
	SGN 19		3/4	19	014-0166
	SGN 6		1/4	-	014-0132 <sup>3)</sup>
	SGN 10		3/8	-	014-0133 <sup>3)</sup>
	SGN 6	Flare int. × ext. <sup>1)</sup>	1/4	6	014-0171
	SGN 10		3/8	10	014-0172
	SGN 12		1/2	12	014-0173
	SGN 16		5/8	16	014-0174
	SGN 19		3/4	19	014-0175
	SGN 6		1/4	-	014-0137 <sup>3)</sup>
	SGN 10		3/8	-	014-0138 <sup>3)</sup>
	SGN 6s	Solder ODF × ODF	1/4	-	014-0181
			-	6	014-0191
	SGN 10s		3/8	-	014-0182
			-	10	014-0192
	SGN 12s		1/2	-	014-0183
			-	12	014-0193
	SGN 16s		5/8	16	014-0184
	SGN 18s		-	18	014-0195
	SGN 19s		3/4	19	014-0185
	SGN 22s		7/8	22	014-0186
	SGN 22s <sup>2)</sup>		1 1/8	-	014-0187
	SGN 6s		1/4	-	014-0142 <sup>3)</sup>
	SGN 10s		3/8	-	014-0143 <sup>3)</sup>
	SGN 12s		1/2	-	014-0144 <sup>3)</sup>
	SGN 16s		5/8	-	014-0145 <sup>3)</sup>
SGN 22s	7/8	-	014-0147 <sup>3)</sup>		
	SGN 6s	Solder ODF × ODM	1/4	-	014-0201
	SGN 10s		3/8	-	014-0202
	SGN 12s		1/2	-	014-0203
	SGN 16s		5/8	16	014-0204
	SGN 22s		7/8	22	014-0206
	SGN 6s		1/4	-	014-0151 <sup>3)</sup>
	SGN 12s		5/16	-	014-0155 <sup>3)</sup>

<sup>1)</sup> Can be screwed directly into the Danfoss filter drier.

<sup>2)</sup> Oversize connections.

<sup>3)</sup> UL approved

<sup>4)</sup> For the code selection of Industrial pack version please contact Danfoss.

**Sight glass (Low pressure) | Types SG, SGN, SGR and SGRN**
**Ordering**  
*(continued)*
**No indicator**

	Valve type	Indicator	Connection type	Connection	Floating ball [pc]	With gasket	Code no. Multi pack <sup>4)</sup>
	SGR	No	G thread	G <sup>3</sup> / <sub>4</sub> A <sup>1)</sup>	1	No	014-0004
			NPT	<sup>3</sup> / <sub>4</sub> – 14 NPT <sup>2)</sup>	1	No	014-0005
			NPT	<sup>1</sup> / <sub>2</sub> – 14 NPT <sup>2)</sup>	3	No	014-0002 <sup>3)</sup>

**With Indicator**

	SGRN	N type	NPT	<sup>1</sup> / <sub>2</sub> – 14 NPT <sup>2)</sup>	3	No	014-0006 <sup>3)</sup>
			M thread	M24 × 1	No	Yes	014-1155 <sup>3)</sup>

<sup>1)</sup> ISO 228-1

<sup>2)</sup> ANSI/ASME B1.20.1

<sup>3)</sup> UL approved

<sup>4)</sup> For the code selection of Industrial pack version please contact Danfoss.

**Saddle**

	Valve type	Connection type	Connection	Tube connection [inch]	Industrial pack [pcs]	Code no.
	SGS	Tube fitting	M20 × 1.5	<sup>7</sup> / <sub>8</sub>	80	014-1073
				1 <sup>1</sup> / <sub>8</sub>	80	014-1071
				1 <sup>3</sup> / <sub>8</sub>	80	014-1074
			M24 × 1	<sup>7</sup> / <sub>8</sub>	80	014-1059
				1 <sup>1</sup> / <sub>8</sub>	80	014-1056
				1 <sup>3</sup> / <sub>8</sub>	80	014-1057
				1 <sup>5</sup> / <sub>8</sub>	80	014-1058
				2 <sup>1</sup> / <sub>8</sub>	80	014-1067

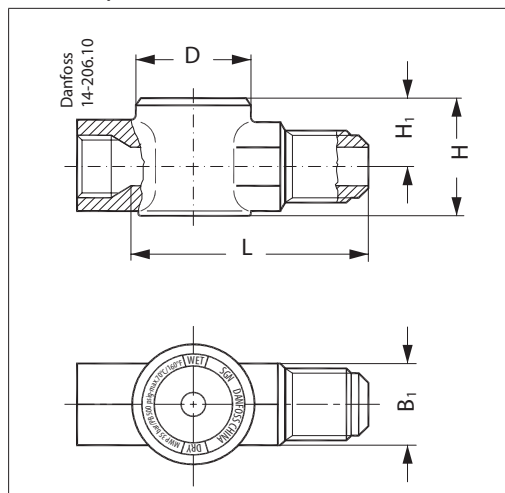
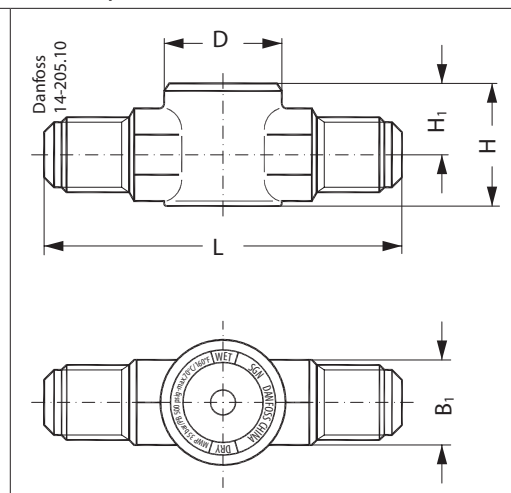
**Dimensions and weights**
**SGN flare, int. x ext.**

**SGN flare, ext. x ext.**

**SI Units**

Type	Connection type	L	H	H <sub>1</sub>	B <sub>1</sub>	øD	Net weight
		[mm]	[mm]	[mm]	[mm]	[mm]	[Kg]
SGN 6	Flare ext. x ext.	67	23	14	14	27	0.1
SGN 10		82	28	15	19	32	0.2
SGN 12		88	30	17	22	32	0.3
SGN 16		104	37	21	27	37	0.4
SGN 19		110	41	22	32	37	0.5
SGN 6	Flare int. x ext.	46	23	14	16	27	0.1
SGN 10		57	30	17	22	32	0.2
SGN 12		59	30	17	24	32	0.3
SGN 16		71	37	21	27	37	0.4
SGN 19		75	41	22	32	37	0.5

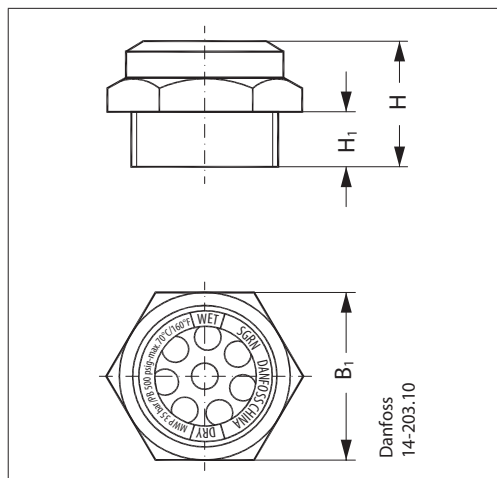
**US Units**

Type	Connection type	L	H	H <sub>1</sub>	B <sub>1</sub>	øD	Net weight
		[inch]	[inch]	[inch]	[inch]	[inch]	[lb]
SGN 6	Flare ext. x ext.	2.64	0.91	0.55	0.55	1.06	0.22
SGN 10		3.23	1.10	0.59	0.75	1.26	0.44
SGN 12		3.46	1.18	0.67	0.87	1.26	0.66
SGN 16		4.09	1.46	0.83	1.06	1.46	0.88
SGN 19		4.33	1.61	0.87	1.26	1.46	1.10
SGN 6	Flare int. x ext.	1.81	0.91	0.55	0.63	1.06	0.22
SGN 10		2.24	1.18	0.67	0.87	1.26	0.44
SGN 12		2.32	1.18	0.67	0.94	1.26	0.66
SGN 16		2.80	1.46	0.83	1.06	1.46	0.88
SGN 19		2.95	1.61	0.87	1.26	1.46	1.10

**Dimensions and weights**  
*(continued)*
**SG socket**

**SI Units**

Type	Connection type	Connection	H	H <sub>1</sub>	B <sub>1</sub>	Net weight
			[mm]	[mm]	[mm]	[kg]
SGR	Pipe thread	G 3/4 A <sup>1)</sup>	23	10	32	0.1
SGR	NPT	1/2 - 14 NPT <sup>2)</sup>	30	18	27	0.1
SGR	NPT	3/4 - 14 NPT <sup>2)</sup>	31	18	32	0.1
SGRN	NPT	1/2 - 14 NPT <sup>2)</sup>	30	18	27	0.1
SGRN	M thread	M24 × 1	28	15	32	0.1

<sup>1)</sup> ISO 228-1

<sup>2)</sup> ANSI/ASME B1.20.1

**US Units**

Type	Connection type	Connection	H	H <sub>1</sub>	B <sub>1</sub>	Net weight
			[inch]	[inch]	[inch]	[lb]
SGR	Pipe thread	G 3/4 A <sup>1)</sup>	0.91	0.39	1.26	0.22
SGR	NPT	1/2 - 14 NPT <sup>2)</sup>	1.18	0.71	1.06	0.22
SGR	NPT	3/4 - 14 NPT <sup>2)</sup>	1.22	0.71	1.26	0.22
SGRN	NPT	1/2 - 14 NPT <sup>2)</sup>	1.18	0.71	1.06	0.22
SGRN	M thread	M24 × 1	1.10	0.59	1.26	0.22

<sup>1)</sup> ISO 228-1

<sup>2)</sup> ANSI/ASME B1.20.1

**Dimensions and weights**  
(continued)

**SGN solder ODF × ODF**

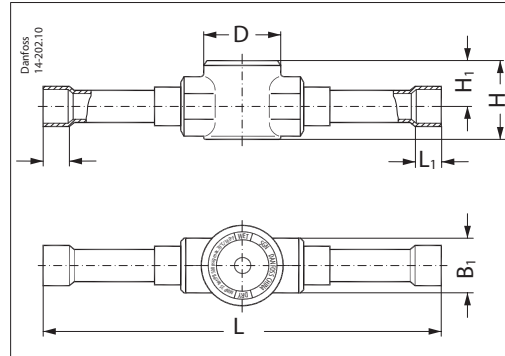

**SGN solder ODF × ODM**

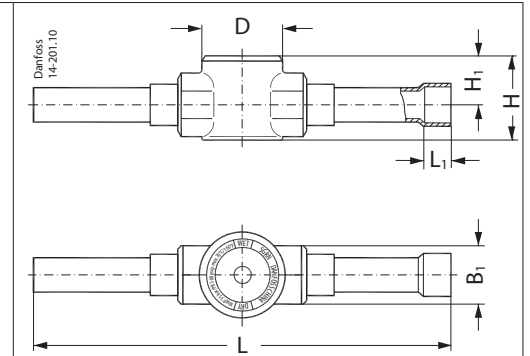

**SI Units**

Type	Connection type	L	L <sub>1</sub>	H	H <sub>1</sub>	B <sub>1</sub>	øD	Net weight
		[mm]	[mm]	[mm]	[mm]	[mm]	[mm]	[kg]
SGN 6s	Solder ODF × ODF	101	7	23	14	14	27	0.1
SGN 10s		119	9	23	14	14	27	0.1
SGN 12s		146	10	28	15	19	27	0.2
SGN 16s		146	12	30	17	22	27	0.2
SGN 18s		173	14	37	21	27	37	0.3
SGN 19s		173	14	37	21	27	37	0.3
SGN 22s		173	17	37	21	27	32	0.3
SGN 22s <sup>1)</sup>		173	22	37	21	27	32	0.3
SGN 6s	Solder ODF × ODM	101	7	23	14	14	27	0.1
SGN 10s		119	9	23	14	14	27	0.1
SGN 12s		146	10	28	15	19	27	0.2
SGN 16s		146	12	30	17	22	27	0.2
SGN 22s		173	17	37	21	27	32	0.3

<sup>1)</sup> Oversize connections

**US Units**

Type	Connection type	L	L <sub>1</sub>	H	H <sub>1</sub>	B <sub>1</sub>	øD	Net weight
		[in.]	[in.]	[in.]	[in.]	[in.]	[in.]	[lb]
SGN 6s	Solder ODF × ODF	3.98	0.28	0.91	0.55	0.55	1.06	0.22
SGN 10s		4.69	0.35	0.91	0.55	0.55	1.06	0.22
SGN 12s		5.75	0.39	1.10	0.59	0.75	1.06	0.44
SGN 16s		5.75	0.47	1.18	0.67	0.87	1.06	0.44
SGN 18s		6.81	0.55	1.46	0.83	1.06	1.46	0.66
SGN 19s		6.81	0.55	1.46	0.83	1.06	1.46	0.66
SGN 22s		6.81	0.67	1.46	0.83	1.06	1.26	0.66
SGN 22s <sup>1)</sup>		6.81	0.87	1.46	0.83	1.06	1.26	0.66
SGN 6s	Solder ODF × ODM	3.98	0.28	0.91	0.55	0.55	1.06	0.22
SGN 10s		4.69	0.35	0.91	0.55	0.55	1.06	0.22
SGN 12s		5.75	0.39	1.10	0.59	0.75	1.06	0.44
SGN 16s		5.75	0.47	1.18	0.67	0.87	1.06	0.44
SGN 22s		6.81	0.67	1.46	0.83	1.06	1.26	0.66

<sup>1)</sup> Oversize connections

Danfoss can accept no responsibility for possible errors in catalogues, brochures and other printed material. Danfoss reserves the right to alter its products without notice. This also applies to products already on order provided that such alterations can be made without subsequent changes being necessary in specifications already agreed. All trademarks in this material are property of the respective companies. Danfoss and the Danfoss logotype are trademarks of Danfoss A/S. All rights reserved.