



Replaceable core filter drier shells (liquid line)

→ BDCY / BCY / BCY-HP (46 bar)

■ Applications

- Refrigerant filtering and drying and acid neutralization for refrigerating and air conditioning installation liquid lines.
- Replaceable core filter drier shells allow the replacement of the filter drier's active parts only.

Shell reference	Core reference (size)
BDCY	CCY 42
BCY / BCY-HP	CCY 48 / PLATINIUM 48
BCY-P6 / BCY-P14	PLATINIUM 48 / CCY 48
BBCY	CCY 100 / PLATINIUM 100



Customized product in stainless steel

Standard product

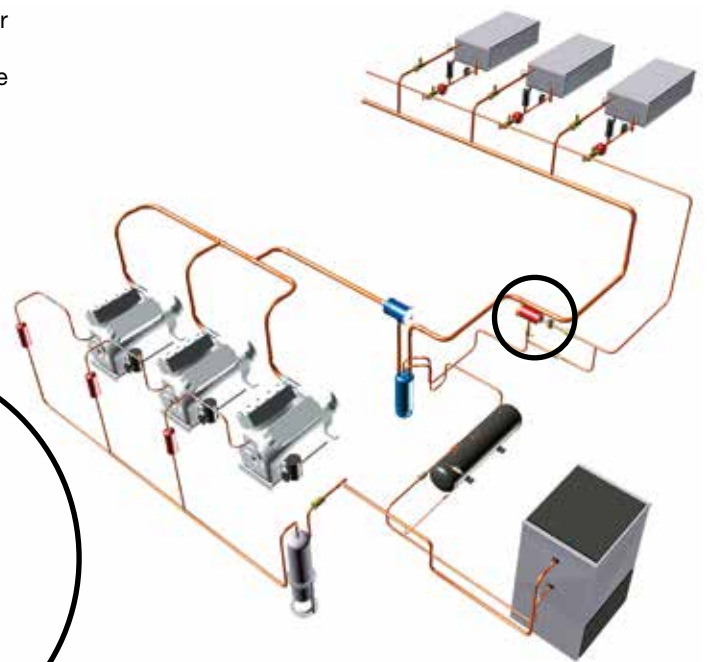

■ Functional features

- Products are compatible with CFCs, HCFCs, HFCs, CO₂, as well as with their associated oils and additives. Products are designed for use of non-hazardous refrigerants from group 2 of PED 2014/68/EU. To use CARLY components with fluids of the hydrocarbon group 1 – Propane R290, Butane R600, Isobutane R600a, Propylene R1270 – with HFOs and transcritical CO₂ and for a RANKINE organic cycle application, contact CARLY technical department.
- Product classification in CE categories is performed using the PED 2014/68/EU table, corresponding to a volume-based selection.
- Filtering at outlet preventing the propagation within the circuit of particles bigger than 150 microns, with a very low pressure drop.
- 1/4" NPT taper tapping and its plug on end plate, allowing the installation of a pressure tap or a feeding valve.
- End plate perfectly tight thanks to its circular rim and its gasket compatible with all CFCs, HCFCs, HFCs and CO₂s.

Possible customization on demand:

- Stainless steel casings and connections (corrosion resistance and for use at very low temperature).
- PS 46 bar for BCY-HP 3 and 4 cores.

■ CARLY advantages

- Maximum working pressure : up to 46 bars for the BCY-HP 1 and 2 cartridges for use with R 410 A and CO₂.
- Individual core holders treated against corrosion by zinc coating, with a reduced course for easy core replacement; therefore, replacement time is extremely reduced, limiting the time the drying cores and the inner part of the circuit are exposed to the atmosphere.
- Hermetically sealed external body made of steel to which an impregnation varnish and paint are applied to ensure a high resistance to corrosion ; this varnish ensures the internal anti-corrosion protection of the shell when it is opened for the initial set-up or during the replacement of the drying cores.
- Core holder design ensures automatic and immediate centring of the filter drier shells.
- No flow area restriction outside the filter drier shells thanks to an appropriate filtering system.



Replaceable core filter drier shells (liquid line)

→ BDCY / BCY / BCY-HP (46 bar)

■ Warning

Before selecting or installing any component, please refer to the chapter 0 - **WARNING**.

■ General assembly precautions

The installation of a component in a refrigeration system by a skilled professional, requires some precautions:

- Some are specific to each component, and in this case, they are specified in the

RECOMMENDATIONS SPECIFIC part defined hereafter ;

- Other are general to all CARLY components, they are presented in the chapter 115 – **GENERAL ASSEMBLY PRECAUTIONS**.

- The recommendations relating to the CARLY components for the subcritical CO₂ applications are also developed in chapter 115 – **GENERAL ASSEMBLY PRECAUTIONS**.

■ Specific recommendations to replaceable core filter drier shells BDCY / BCY / BCY-HP

- Filter drier shells are to be mounted on the liquid line between the receiver and the expansion element.
- The refrigerant flow direction, indicated by an arrow on the filter drier shells' tags, should be complied with.
- Assembly can be performed in any position, but not vertically with the outlet connection oriented downwards.
- During filter drier shells assembly, provide for sufficient course to allow core replacement (refer to sizes L2 in the technical features table).
- The connection to the installation, by soldering or welding, of the filter shell, must be done only after removing the closing flange, its gasket and the internal core holders.
- We recommend to clean and to protect the connections of the filter drier shell with appropriate products in order to ensure a good resistance to corrosion of the affected areas.
- Be careful to properly select the solenoid valves located downstream of the filter drier shells; their oversizing could cause liquid hammer phenomena hindering the filter drier shells' proper mechanical behaviour; protection of the regulation elements upstream of the evaporator should be performed with FILTRY dirt filters (refer to chapter 11); these liquid hammer phenomena can originate from other sources, in long-piping installations.
- Never install filter drier shells in an area of the circuit that can be isolated.
- Never trap refrigerant in its liquid state (between a check valve and a solenoid valve, for instance).
- The filter drier shells' efficiency and the refrigerant's moisture content should be checked using VCYL or VCYLS liquid sight glasses (refer to chapter 9 or 10).
- Make sure that the piping can support without deformation the weight of the filter drier shell ; otherwise, provide for a clamp of the filter drier shell with a clamp on a stable part of the installation.
- In order to avoid risk of frost and condensation on the suction filter shells mounted on a cold pipe, it is recommended to insulate them thermally.

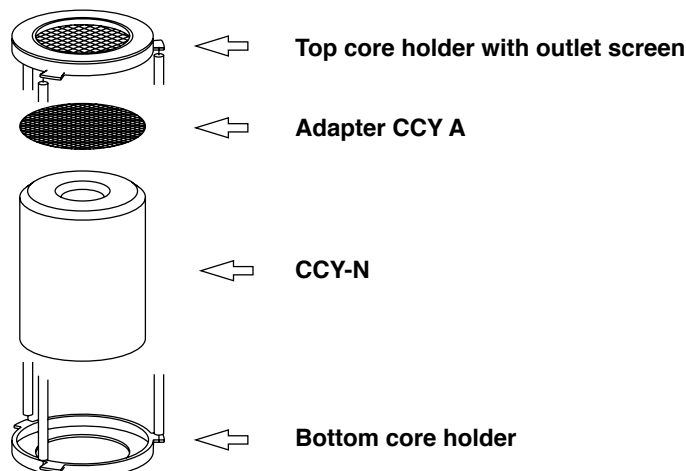



Replaceable core filter drier shells (liquid line)

→ **BDCY** (corresponding cores: CCY 42)

■ Core replacement procedure

- 1 • Isolate the **BDCY** filter drier shell.
- 2 • Purge the installation up to atmospheric pressure (shell should be empty of refrigerants)
- 3 • Remove the end plate.
- 4 • Remove the bottom core holder.
- 5 • Remove the used core.
- 6 • Clean and replace if necessary, the **CCY A 42** adapter and the outlet screen.
- 7 • Check and replace if necessary, the outlet gasket of top core holder.
- 8 • Replace systematically the end plate gasket.
- 9 • Remove the **CCY 42** core from its sealed can.
- 10 • Reassemble in order: the outlet screen (1), the **CCY A 42** adapter (2), the outlet gasket (3), the top core holder (4), the **CCY 42** core, the bottom core holder and its compression spring (5) (sketch below)
- 11 • Reinstall the closing flange making sure that the compression spring is correctly positioned and gradually and uniformly tighten the closing screws (refer to chapter 115 – **GENERAL MOUNTING PRECAUTIONS** – Criss-cross tightening).
Maximum bolt tightening torque: 30 N.m.
- 12 • Make sure that the end plate's 1/4" NPT taper tapping has been properly plugged in and sealed.
- 13 • Make vacuum in the installation and check air-tightness of the whole set before putting back under pressure.

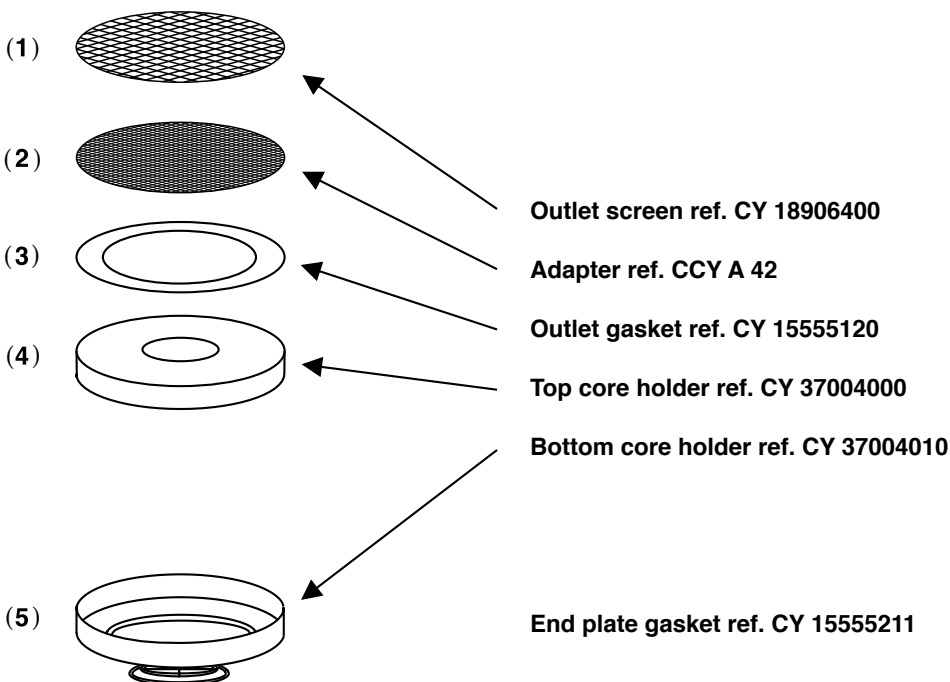



Replaceable core filter drier shells (liquid line)

→ BDCY (corresponding cores: CCY 42)

■ Selection table

CARLY references	Connections To solder ODF inch	CARLY references	Connections To solder ODF mm	Refrigerating capacity kW ⁽¹⁾					Number of cores
				R22	R134a	R404A R507 R407F	R407C R410A	R744 ⁽²⁾	
BDCY 424 S	1/2	BDCY 424 MMS	12	19,0	17,0	12,0	19,0	22,0	1
BDCY 425 S/MMS	5/8	BDCY 425 S/MMS	16	27,0	25,0	18,0	27,0	31,0	1
BDCY 427 S/MMS	7/8	BDCY 427 S/MMS	22	45,0	41,0	29,0	44,0	51,0	1

⁽¹⁾ Refrigerating capacities according to Standard ARI 710-86 for $T_o = -15\text{ °C}$, $T_k = 30\text{ °C}$ and $\Delta p = 0.07\text{ bar}$.
If different conditions, refer to correction factors in chapter 112.

⁽²⁾ Refrigerating capacities Q_n for $T_k = -10\text{ °C}$ and $T_o = -40\text{ °C}$
If different conditions, refer to correction factors in chapter 112.

Nota: the diameter of connections must not be inferior to the diameter of the main pipe.

■ Technical features

CARLY references	Connection types ⁽¹⁾	Filtering surface cm ²				Dimensions mm						
		CCY 42 HP CCY 42 N	CCY 42 F	CCY 42 I	Ø1	Ø2	Ø3	L1	L2	E1	E2	
BDCY 424 S	BDCY 424 MMS	2	374	329	348	89	96	124	218	210	152	65
BDCY 425 S/MMS		2	374	329	348	89	96	124	220	210	155	67
BDCY 427 S/MMS		2	374	329	348	89	96	124	230	210	163	76

⁽¹⁾ Chapter «Connection features and drawings» (refer to chapter 114).

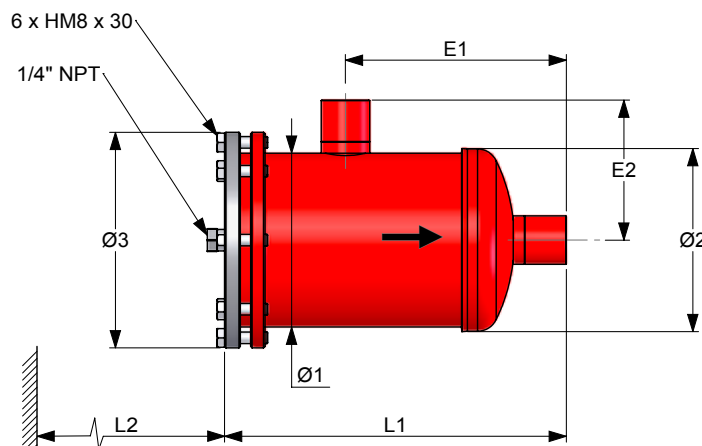

CARLY references	Volume V L	Maximal working pressure PS bar	Working pressure ⁽¹⁾ PS BT bar	Maximal working temperature TS maxi °C	Minimal working temperature TS mini °C	Working temperature ⁽¹⁾ TS BT °C	CE Category ⁽²⁾	
								BDCY 424 S
BDCY 425 S/MMS		1,00	42	15	100	-40	-30	Art4S3
BDCY 427 S/MMS		1,10	42	15	100	-40	-30	Art4S3

⁽¹⁾ The working pressure is limited to the PS BT value when working temperature is lower than or equal to TS BT value.

⁽²⁾ Classification by volume, according to PED 2014/68/EU (refer to chapter 0).



Replaceable core filter drier shells (liquid line)

→ **BDCY** (corresponding cores: CCY 42)

■ Spare parts

CARLY references	Part N°	Description	Quantity
CY 19900410	1	Set of 6 fastening screws for end plate	1
CY 10810010	2	1/4" NPT phosphate plug for end plate	1
CY 33301000	2 + 3 + 5	1/4" NPT plug + end plate + gasket	1
CY 37004010	4	Bottom core holder	1
CY 15555211	5	End plate gasket (red)	1
CY 37004000	6	Top core holder	1
CCY A 42	7	Adapter for end core holders	1

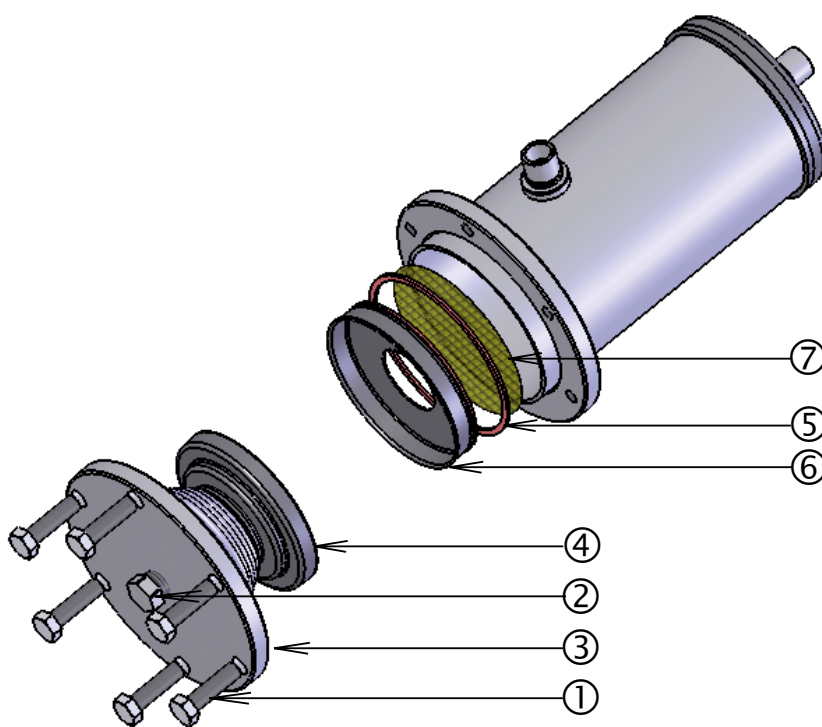

■ Weights and packaging

CARLY references	Unit weight kg		Packaging number of pieces
	With packaging	Without packaging	
BDCY 424 S & MMS	2,85	2,60	1
BDCY 425 S/MMS	2,90	2,65	1
BDCY 427 S/MMS	2,95	2,70	1





Replaceable core filter drier shells (liquid line)

→ **BCY / BCY-HP** (corresponding cores: CCY 48 and PLATINIUM 48)

■ Core replacement procedure

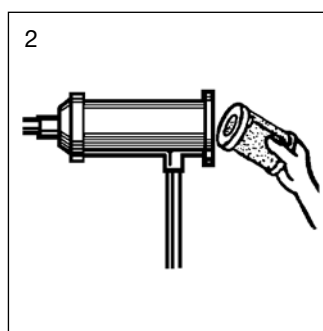
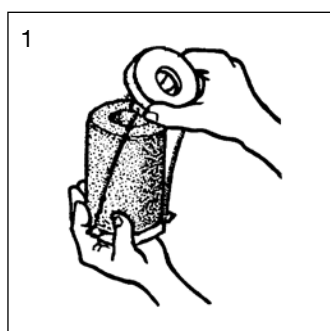
- 1 • Isolate the **BCY / BCY-HP** filter drier shell.
- 2 • Purge the installation up to atmospheric pressure (shell should be empty of refrigerants)
- 3 • Remove the end plate.
- 4 • Remove the core holders one after the other.
- 5 • Remove the used cores.
- 6 • Clean very carefully the core holders, the adapter (**CCY A 48**) and the inner part of the shell case.
- 7 • Replace systematically the gasket on the end plate and check the core holder and core end gaskets.
- 8 • Remove the core from its can and put it on the core holder, separating by traction the two flanges that hold the core holder (sketch 1)
- 9 • Repeat the operation for each core holder.
- 10 • Quickly install the core holders with their core in the shell, complying with their mounting order: the first one holds the filter elements and the last one is the one equipped with the compression spring (sketch 2)
- 11 • Reinstall the closing flange making sure that the compression spring is correctly positioned and gradually and uniformly tighten the closing screws (refer to chapter 115 – **GENERAL MOUNTING PRECAUTIONS** – Criss-cross tightening). Maximum bolt tightening torque: 30 N.m.
- 12 • Make sure that the end plate's 1/4" NPT taper tapping has been properly plugged in and sealed.
- 13 • Make vacuum in the installation and check air-tightness of the whole set before putting back under pressure.



 The standard gasket of the CCY (neoprene) is not compatible with CO₂. Use the reference CY 1555200.



Replaceable core filter drier shells (liquid line)

➔ **BCY** (corresponding cores: CCY 48 and PLATINIUM 48)

■ Selection table

CARLY references	Connections To solder ODF inch	CARLY references	Connections To solder ODF mm	Refrigerating capacity KW ⁽¹⁾					Number of cores
				R22	R134a	R404A R507 R407F	R407C R410A	R744 ⁽²⁾	
BCY 485 S/MMS	5/8	BCY 485 S/MMS	16	94,0	86,0	61,0	93,0	106,0	1
BCY 487 S/MMS	7/8	BCY 487 S/MMS	22	153,0	139,0	100,0	151,0	171,0	1
BCY 489 S	1 1/8	BCY 489 MMS	28	207,0	188,0	135,0	205,0	232,0	1
BCY 4811 S/MMS	1 3/8	BCY 4811 S/MMS	35	247,0	225,0	161,0	245,0	277,0	1
BCY 4813 S	1 5/8	BCY 4813 MMS	42	300,0	273,0	195,0	297,0	336,0	1
BCY 4817 S/MMS	2 1/8	BCY 4817 S/MMS	54	350,0	319,0	228,0	347,0	392,0	1
BCY 967 S/MMS	7/8	BCY 967 S/MMS	22	157,0	143,0	102,0	155,0	176,0	2
BCY 969 S	1 1/8	BCY 969 MMS	28	235,0	214,0	153,0	233,0	264,0	2
BCY 9611 S/MMS	1 3/8	BCY 9611 S/MMS	35	334,0	304,0	217,0	331,0	375,0	2
BCY 9613 S	1 5/8	BCY 9613 MMS	42	410,0	373,0	267,0	406,0	460,0	2
BCY 9617 S/MMS	2 1/8	BCY 9617 S/MMS	54	414,0	377,0	269,0	410,0	464,0	2
BCY 1449 S	1 1/8	BCY 1449 MMS	28	375,0	341,0	244,0	371,0	420,0	3
BCY 14411 S/MMS	1 3/8	BCY 14411 S/MMS	35	400,0	364,0	260,0	396,0	448,0	3
BCY 14413 S	1 5/8	BCY 14413 MMS	42	415,0	378,0	270,0	411,0	465,0	3
BCY 14417 S/MMS	2 1/8	BCY 14417 S/MMS	54	445,0	405,0	290,0	441,0	499,0	3
BCY 19213 S	1 5/8	BCY 19213 MMS	42	525,0	478,0	342,0	520,0	588,0	4
BCY 19217 S/MMS	2 1/8	BCY 19217 S/MMS	54	560,0	510,0	364,0	554,0	628,0	4

⁽¹⁾ Refrigerating capacities according to Standard ARI 710-86 for $T_o = -15\text{ °C}$, $T_k = 30\text{ °C}$ and $\Delta p = 0.07\text{ bar}$.
If different conditions, refer to correction factors in chapter 112.

⁽²⁾ Refrigerating capacities Q_n for $T_k = -10\text{ °C}$ and $T_o = -40\text{ °C}$
If different conditions, refer to correction factors in chapter 112.

Nota: the diameter of connections must not be inferior to the diameter of the main pipe.



CTCY-EN – 6.1-8 / 07-2018

Replaceable core filter drier shells (liquid line)

→ **BCY** (corresponding cores: CCY 48 and PLATINIUM 48)

■ Technical features

CARLY references	Connection types ⁽¹⁾	Filtering surface cm ²	Dimensions mm							
			Ø1	Ø2 ⁽²⁾	Ø3	L1	L2	E1	E2	
BCY 485 S/MMS	2	420	121	128	150	223	210	139	83	
BCY 487 S/MMS	2	420	121	128	150	233	210	149	93	
BCY 489 S	BCY 489 MMS	3	420	121	128	150	238	210	154	98
BCY 4811 S/MMS		3	420	121	128	150	247	210	163	108
BCY 4813 S	BCY 4813 MMS	3	420	121	128	150	247	210	163	108
BCY 4817 S/MMS		3	420	121	128	150	260	210	176	124
BCY 967 S/MMS		2	840	121	128	150	373	210	289	93
BCY 969 S	BCY 969 MMS	3	840	121	128	150	378	210	294	98
BCY 9611 S/MMS		3	840	121	128	150	387	210	303	108
BCY 9613 S	BCY 9613 MMS	3	840	121	128	150	387	210	303	108
BCY 9617 S/MMS		3	840	121	128	150	400	210	316	124
BCY 1449 S	BCY 1449 MMS	3	1260	121	128	150	518	210	434	98
BCY 14411 S/MMS		3	1260	121	128	150	527	210	443	108
BCY 14413 S	BCY 14413 MMS	3	1260	121	128	150	527	210	443	108
BCY 14417 S/MMS		3	1260	121	128	150	540	210	456	124
BCY 19213 S	BCY 19213 MMS	3	1680	121	128	150	672	210	588	108
BCY 19217 S/MMS		3	1680	121	128	150	685	210	601	124

⁽¹⁾ Chapter «Connection features and drawings» (refer to chapter 114).

⁽²⁾ Including weld.

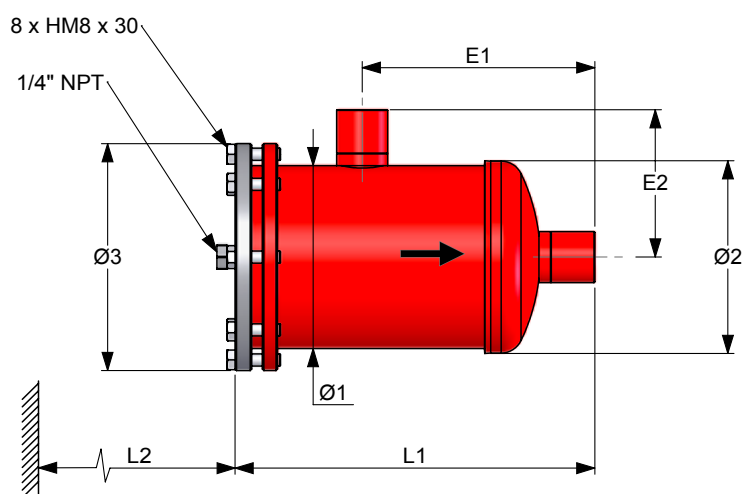



Replaceable core filter drier shells (liquid line)

➔ **BCY** (corresponding cores: CCY 48 and PLATINIUM 48)

■ Technical features

CARLY references	Volume	Maximal working pressure	Working pressure ⁽¹⁾	Maximal working temperature	Minimal working temperature	Working temperature ⁽¹⁾	CE Category ⁽²⁾	
	V L	PS bar	PS BT bar	TS maxi °C	TS mini °C	TS BT °C		
BCY 485 S/MMS	1,90	35	15	100	-40	-30	I	
BCY 487 S/MMS	1,90	35	15	100	-40	-30	I	
BCY 489 S	BCY 489 MMS	1,90	35	15	100	-40	-30	I
BCY 4811 S/MMS		1,90	35	15	100	-40	-30	I
BCY 4813 S	BCY 4813 MMS	1,90	35	15	100	-40	-30	I
BCY 4817 S/MMS		2,00	35	15	100	-40	-30	I
BCY 967 S/MMS		3,30	35	15	100	-40	-30	I
BCY 969 S	BCY 969 MMS	3,30	35	15	100	-40	-30	I
BCY 9611 S/MMS		3,30	35	15	100	-40	-30	I
BCY 9613 S	BCY 9613 MMS	3,30	35	15	100	-40	-30	I
BCY 9617 S/MMS		3,40	35	15	100	-40	-30	I
BCY 1449 S	BCY 1449 MMS	4,90	35	15	100	-40	-30	I
BCY 14411 S/MMS		5,00	35	15	100	-40	-30	I
BCY 14413 S	BCY 14413 MMS	5,00	35	15	100	-40	-30	I
BCY 14417 S/MMS		5,10	35	15	100	-40	-30	I
BCY 19213 S	BCY 19213 MMS	6,40	31*	15	100	-40	-30	I
BCY 19217 S/MMS		6,40	31*	15	100	-40	-30	I

⁽¹⁾ The working pressure is limited to the PS BT value when working temperature is lower than or equal to TS BT value.

⁽²⁾ Classification by volume, according to PED 2014/68/EU (refer to chapter 0).

* 35 bar working pressure possible on demand



Replaceable core filter drier shells (liquid line)

➔ **BCY** (corresponding cores: CCY 48 and PLATINIUM 48)

■ Spare parts

Shells	CARLY References for core holders	Quantity and type of gaskets for use	
		Core holders gasket ⁽¹⁾	End plate gasket ⁽²⁾
BCY 1 core	CY 37001070/CY 37001076	1 gasket CY 15558700/CY 15555200	
BCY 2 cores	CY 37001030 + CY 37001090/CY 37001096	1 gasket CY 15555200 +1 gasket CY 15558700/CY 15555200	
BCY 3 cores	CY 37001030 + CY 37001080 + CY 37001090/CY 37001096	2 gaskets CY 15555200 +1 gasket CY 15558700/CY 15555200	1 gasket CY 15555601
BCY 4 cores	CY 37001030 + CY 37001080 + CY 37001040 + CY 37001090/CY 37001096	3 gaskets CY 15555200 +1 gasket CY 15558700/CY 15555200	

⁽¹⁾ Gasket delivered with core holders

⁽²⁾ Gasket delivered with cores CCY 48 N, CCY 48 HP and PLATINIUM 48

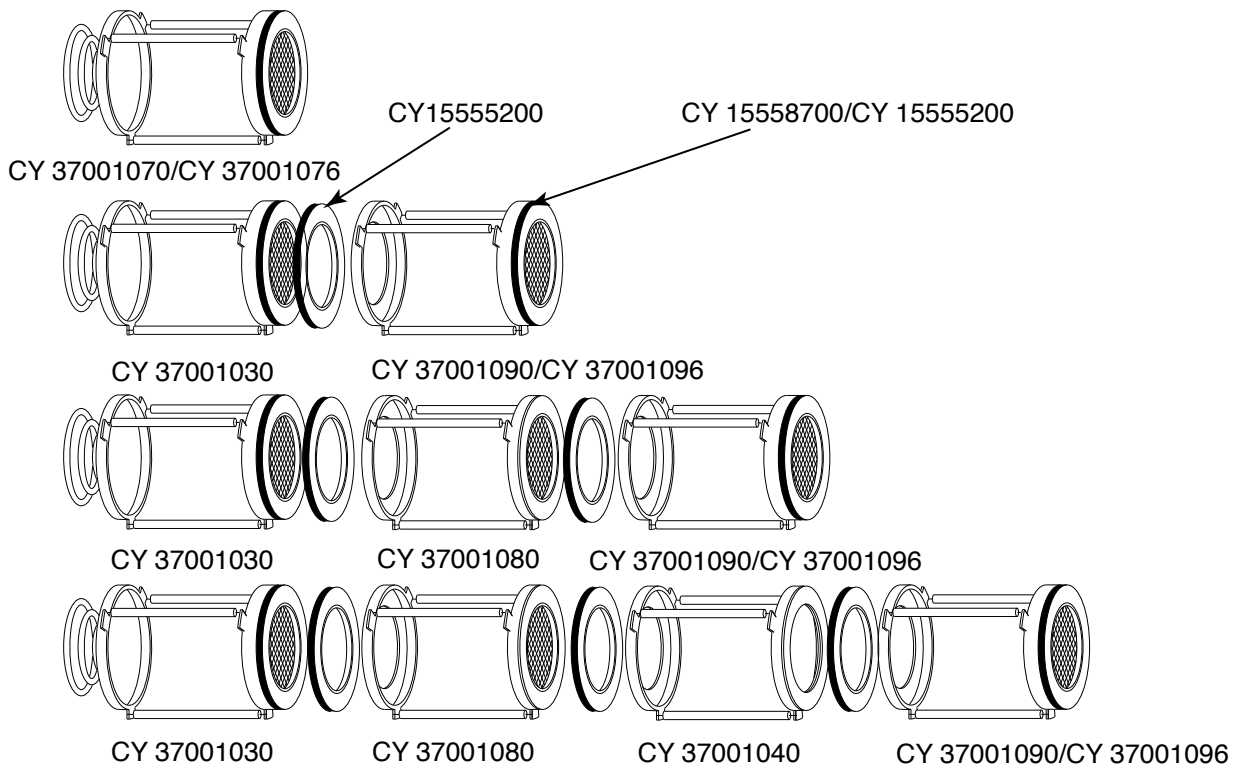



Replaceable core filter drier shells (liquid line)

➔ **BCY** (corresponding cores: CCY 48 and PLATINIUM 48)

■ Spare parts

CARLY references	Part N°	Désignation	Quantity
CY 19900411	1	Set of 8 fastening screws for end plate	1
CY 10810010	2	1/4" NPT phosphate plug for end plate	1
CY 33301200	2 + 3 + 5	1/4" NPT plug + end plate + gasket	1
CY 37001030	4	Core holder (2, 3 and 4 cores)	1
CY 37001040	4	Core holder (4 cores)	1
CY 37001070/ CY 37001076	4	Core holder (1 core)	1
CY 37001080	4	Core holder (3 and 4 cores)	1
CY 37001090/ CY 37001096	4	Core holder (2, 3 and 4 cores)	1
CY 15555601	5	End plate gasket (red)	1
CY 15555200	6	Adhesive gasket for core holders: CY 37001030, CY 37001040, CY 37001080, CY37001070/CY37001076, CY37001090/CY37001096	1
CCY A 48	7	Adapter for end core holder	1
CY 15555000		Bag of gaskets for shell end plates : CARLY and for most manufacturers (gaskets: 122 x 114 x 1.6 and 114 x 103 x 1.6)	1

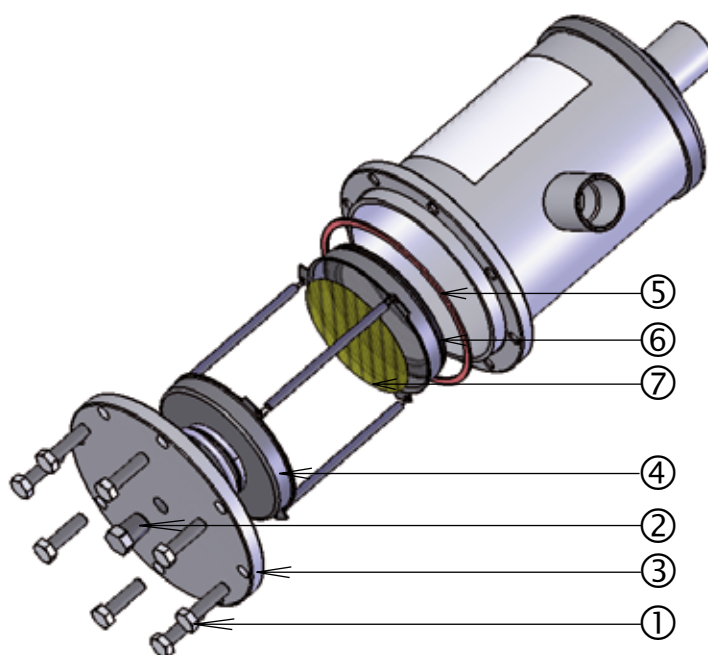



Replaceable core filter drier shells (liquid line)

→ BCY (corresponding cores: CCY 48 and PLATINIUM 48)

■ Weights and packaging

CARLY references	Unit weight kg		Packaging number of pieces
	With packaging	Without packaging	
BCY 485 S/MMS	4,45	4,20	1
BCY 487 S/MMS	4,55	4,30	1
BCY 489 S & MMS	4,65	4,40	1
BCY 4811 S/MMS	4,70	4,45	1
BCY 4813 S & MMS	4,80	4,55	1
BCY 4817 S/MMS	5,05	4,80	1
BCY 967 S/MMS	5,90	5,60	1
BCY 969 S & MMS	5,95	5,65	1
BCY 9611 S/MMS	6,15	5,85	1
BCY 9613 S & MMS	6,25	5,95	1

CARLY references	Unit weight kg		Packaging number of pieces
	With packaging	Without packaging	
BCY 9617 S/MMS	6,40	6,10	1
BCY 1449 S & MMS	7,20	6,85	1
BCY 14411 S/MMS	7,40	7,05	1
BCY 14413 S & MMS	7,45	7,10	1
BCY 14417 S/MMS	7,70	7,35	1
BCY 19213 S & MMS	8,65	8,25	1
BCY 19217 S/MMS	9,05	8,65	1

→ BCY-HP (46 bar) (corresponding cores: CCY 48 and PLATINIUM 48)

■ Selection table

CARLY references	Connections To solder ODF inch	CARLY references	Connections To solder ODF mm	Refrigerating capacity kW ⁽¹⁾					Number of cores
				R22	R134a	R404A R507 R407F	R407C R410A	R744 ⁽²⁾	
BCY-HP 485 S/MMS	5/8	BCY-HP 485 S/MMS	16	94,0	86,0	61,0	93,0	106,0	1
BCY-HP 487 S/MMS	7/8	BCY-HP 487 S/MMS	22	153,0	139,0	100,0	151,0	171,0	1
BCY-HP 489 S	1 1/8	BCY-HP 489 MMS	28	207,0	188,0	135,0	205,0	232,0	1
BCY-HP 4811 S/MMS	1 3/8	BCY-HP 4811 S/MMS	35	247,0	225,0	161,0	245,0	277,0	1
BCY-HP 4813 S	1 5/8	BCY-HP 4813 MMS	42	300,0	273,0	195,0	297,0	336,0	1
BCY-HP 4817 S/MMS	2 1/8	BCY-HP 4817 S/MMS	54	350,0	319,0	228,0	347,0	392,0	1
BCY-HP 967 S/MMS	7/8	BCY-HP 967 S/MMS	22	157,0	143,0	102,0	155,0	176,0	2
BCY-HP 969 S	1 1/8	BCY-HP 969 MMS	28	235,0	214,0	153,0	233,0	264,0	2
BCY-HP 9611 S/MMS	1 3/8	BCY-HP 9611 S/MMS	35	334,0	304,0	217,0	331,0	375,0	2
BCY-HP 9613 S	1 5/8	BCY-HP 9613 MMS	42	410,0	373,0	267,0	406,0	460,0	2
BCY-HP 9617 S/MMS	2 1/8	BCY-HP 9617 S/MMS	54	414,0	377,0	269,0	410,0	464,0	2

⁽¹⁾ Refrigerating capacities according to Standard ARI 710-86 for $T_o = -15\text{ °C}$, $T_k = 30\text{ °C}$ and $\Delta p = 0.07\text{ bar}$.
If different conditions, refer to correction factors in chapter 112.

⁽²⁾ Refrigerating capacities Q_n for $T_k = -10\text{ °C}$ and $T_o = -40\text{ °C}$
If different conditions, refer to correction factors in chapter 112.

Nota: the diameter of connections must not be inferior to the diameter of the main pipe.



Replaceable core filter drier shells (liquid line)

→ BCY-HP (46 bar) (corresponding cores: CCY 48 and PLATINIUM 48)

■ Technical features

CARLY references	Connection types ⁽¹⁾	Filtering surface cm ²	Dimensions mm							
			Ø1	Ø2 ⁽²⁾	Ø3	L1	L2	E1	E2	
BCY-HP 485 S/MMS	2	420	121	128	150	223	210	139	83	
BCY-HP 487 S/MMS	2	420	121	128	150	233	210	149	93	
BCY-HP 489 S	BCY-HP 489 MMS	3	420	121	128	150	238	210	154	98
BCY-HP 4811 S/MMS		3	420	121	128	150	247	210	163	108
BCY-HP 4813 S	BCY-HP 4813 MMS	3	420	121	128	150	247	210	163	108
BCY-HP 4817 S/MMS		3	420	121	128	150	260	210	176	124
BCY-HP 967 S/MMS		2	840	121	128	150	373	210	289	93
BCY-HP 969 S	BCY-HP 969 MMS	3	840	121	128	150	378	210	294	98
BCY-HP 9611 S/MMS		3	840	121	128	150	387	210	303	108
BCY-HP 9613 S	BCY-HP 9613 MMS	3	840	121	128	150	387	210	303	108
BCY-HP 9617 S/MMS		3	840	121	128	150	400	210	316	124

⁽¹⁾ Chapter «Connection features and drawings» (refer to chapter 114).

⁽²⁾ Including weld.

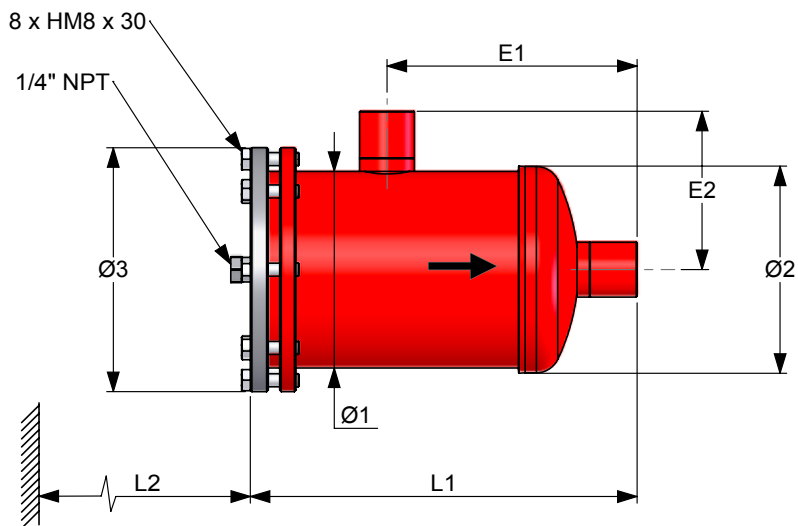



Replaceable core filter drier shells (liquid line)

→ **BCY-HP (46 bar)** (corresponding cores: CCY 48 and PLATINIUM 48)

■ Technical features

CARLY references	Volume	Maximal working pressure	Working pressure ⁽¹⁾	Maximal working temperature	Minimal working temperature	Working temperature ⁽¹⁾	CE Category ⁽²⁾	
								V L
BCY-HP 485 S/MMS	1,90	46	15	120	-40	-30	I	
BCY-HP 487 S/MMS	1,90	46	15	120	-40	-30	I	
BCY-HP 489 S	BCY-HP 489 MMS	1,90	46	15	120	-40	-30	I
BCY-HP 4811 S/MMS		1,90	46	15	120	-40	-30	I
BCY-HP 4813 S	BCY-HP 4813 MMS	1,90	46	15	120	-40	-30	I
BCY-HP 4817 S/MMS		2,00	46	15	120	-40	-30	I
BCY-HP 967 S/MMS		3,30	46	15	120	-40	-30	I
BCY-HP 969 S	BCY-HP 969 MMS	3,30	46	15	120	-40	-30	I
BCY-HP 9611 S/MMS		3,30	46	15	120	-40	-30	I
BCY-HP 9613 S	BCY-HP 9613 MMS	3,30	46	15	120	-40	-30	I
BCY-HP 9617 S/MMS		3,40	46	15	120	-40	-30	I

⁽¹⁾ The working pressure is limited to the PS BT value when working temperature is lower than or equal to TS BT value.

⁽²⁾ Classification by volume, according to PED 2014/68/EU (refer to chapter 0).

■ Spare parts

Shells	CARLY References for core holders	Quantity and type of gaskets for use	
		Core holders gasket ⁽¹⁾	End plate gasket ⁽²⁾
BCY-HP 1 core	CY 37001076	1 gasket CY 15555200	1 gasket CY 15555601
BCY-HP 2 cores	CY 37001030 + CY 37001096	2 gaskets CY 15555200	

⁽¹⁾ Gasket delivered with core holders

⁽²⁾ Gasket delivered with cores CCY 48 N, CCY 48 HP and PLATINIUM 48

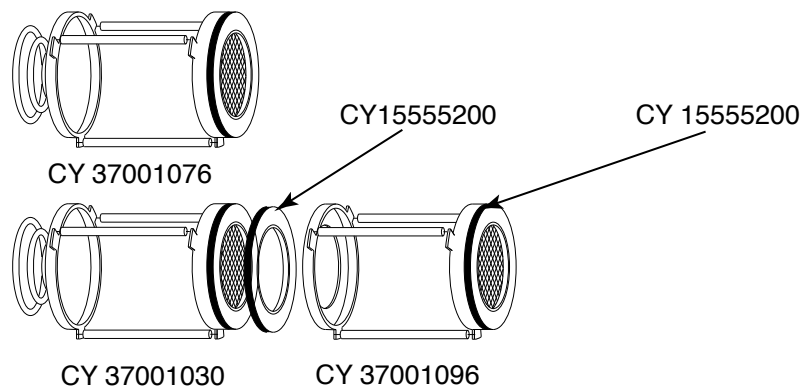



Replaceable core filter drier shells (liquid line)

➔ **BCY-HP (46 bar)** (corresponding cores: CCY 48 and PLATINIUM 48)

■ Spare parts

CARLY references	Part N°	Désignation	Quantity
CY 19900411	1	Set of 8 fastening screws for end plate	1
CY 10810010	2	1/4" NPT phosphate plug for end plate	1
CY 33301200	2 + 3 + 5	1/4" NPT plug + end plate + gasket	1
CY 37001030	4	Core holder (2 cores)	1
CY 37001076	4	Core holder (1 core)	1
CY 37001096	4	Core holder (2 cores)	1
CY 15555601	5	End plate gasket (red)	1
CY 15555200	6	Adhesive gasket for core holders:: CY 37001030, CY 37001040, CY 37001080, CY37001076 and CY3700199	1
CCY A 48	7	Adapter for end core holder	1
CY 15555000		Bag of gaskets for shell end plates : CARLY and for most manufacturers (gaskets: 122 x 114 x 1.6 and 114 x 103 x 1.6)	1

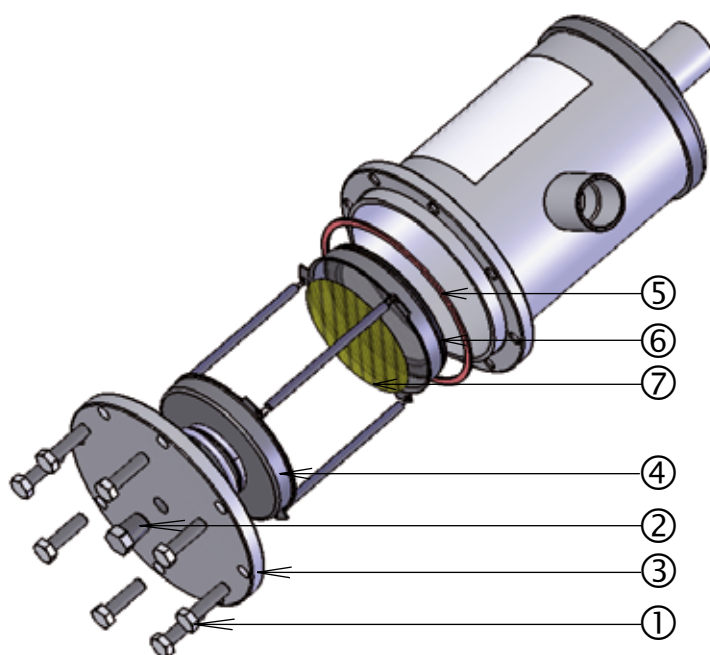

■ Weights and packaging

CARLY references	Unit weight kg		Packaging number of pieces	CARLY references	Unit weight kg		Packaging number of pieces
	With packaging	Without packaging			With packaging	Without packaging	
BCY-HP 485 S/MMS	4,45	4,20	1	BCY-HP 967 S/MMS	5,90	5,60	1
BCY-HP 487 S/MMS	4,55	4,30	1	BCY-HP 969 S & MMS	5,95	5,65	1
BCY-HP 489 S & MMS	4,65	4,40	1	BCY-HP 9611 S/MMS	6,15	5,85	1
BCY-HP 4811 S/MMS	4,70	4,45	1	BCY-HP 9613 S & MMS	6,25	5,95	1
BCY-HP 4813 S & MMS	4,80	4,55	1	BCY-HP 9617 S/MMS	6,40	6,10	1
BCY-HP 4817 S/MMS	5,05	4,80	1				