

Condensing Unit Technical Data Sheet

Model CGLY12RAa_N
Voltage 220-240V 50Hz ~1
Refrigerant R134a

APPLICATION

Application High Back Pressure
 Refrigerant R134a
 Evaporating Temp. -15,0 °C to 10,0 °C
 Expansion Capillar/Valve
 Comp. Cooling Fan cooled
 Max. ambient temp. 43,0 °C

COMPRESSOR

Displacement 10,70 cm³
 Diameter 25,40 mm
 Stroke 21,12 mm
 Oil type ISO VG 32 ESTER
 Oil charge 350 cm³

MOTOR

Nominal Power 3/8 hp
 Voltage/Frequency 220-240V 50Hz
 Voltage range 198-255 V
 Type CSIR
 Phase number 1 PH
 Locked Rotor Amps (LRA) 14,80 A
 Max. Cont. Current (MCC) 3,60 A
 Main W. resist. at 25°C 8,43 Ω
 Start W. resist. at 25°C 31,30 Ω

NOMINAL PERFORMANCE

Cooling Capacity	1.048 W
COP	1,99 W/W
EER	1,71 kCal/Wh
Input Power	527 W
Current	2,43 A

ASHRAE

TEST CYCLE CONDITIONS

	HBP
Evaporating temp. (T _e)	7,2 °C
Condensing temp. (T _c)	55,0 °C
Liquid temp. (T _{liq.})	46,0 °C
Ambient temp. (T _{amb.})	35,0 °C
Suction temp. (T _{suction})	35,0 °C
Voltage/Frequency	220 V 50 Hz

CONDENSER AND FAN DATA

Condenser type	CU-AL
Condenser model	9T 3R
Fan blade (Ø mm / °)	230 / 28
Fan motor	10W 230V 50/60Hz

WIRING DIAGRAM

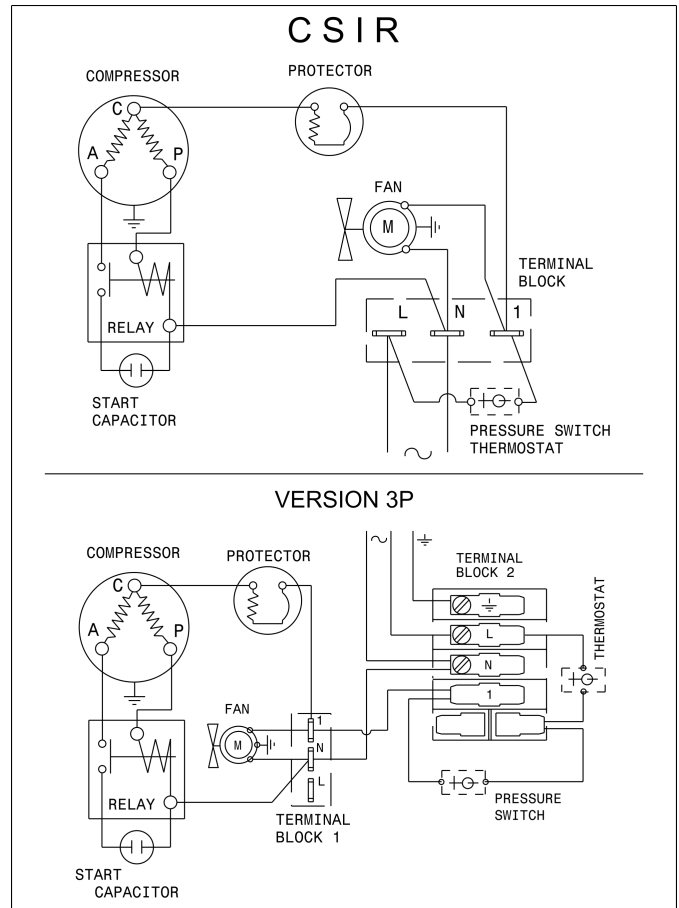

REFRIGERATION CAPACITY (W) Evaporating Temperature (°C)

Model	Motor	-25	-15	-5	5	7.2			10
						W	Winp	A	
CGLY12RAa_N	CSIR	-	422	662	971	1048	527	2.43	1151

ASHRAE HBP: Condensing temperature: 55°C, Liquid temperature: 46°C, Suction temperature: 35°C, Ambient temperature: 35°C

Condensing Unit Technical Data Sheet

VERSIONS

VERSION 1	VERSION 2	VERSION 3	VERSION 3P	VERSION 4
Tube	Service valve	Service valve and receiver	Service valve, receiver, pressure switch	Schrader valve on the service port
Suction tube internal diam.: 8,1 mm Discharge tube internal diam.: 6,5 mm Net Weight: 19,7 Kg	Suction valve: 3/8" Discharge valve: 1/4" Net Weight: 20,2 Kg	Receiver vol.: 0,9 l Suction valve: 3/8" Discharge valve: 1/4" Net Weight: 20,5 Kg	Receiver vol.: 0,9 l Suction valve: 3/8" Discharge valve: 1/4" Net Weight: 21,6 Kg	Suction tube internal diam.: 8,1 mm Discharge tube internal diam.: 6,5 mm Net Weight: 19,7 Kg

DIMENSIONS (Version 3 drawing)

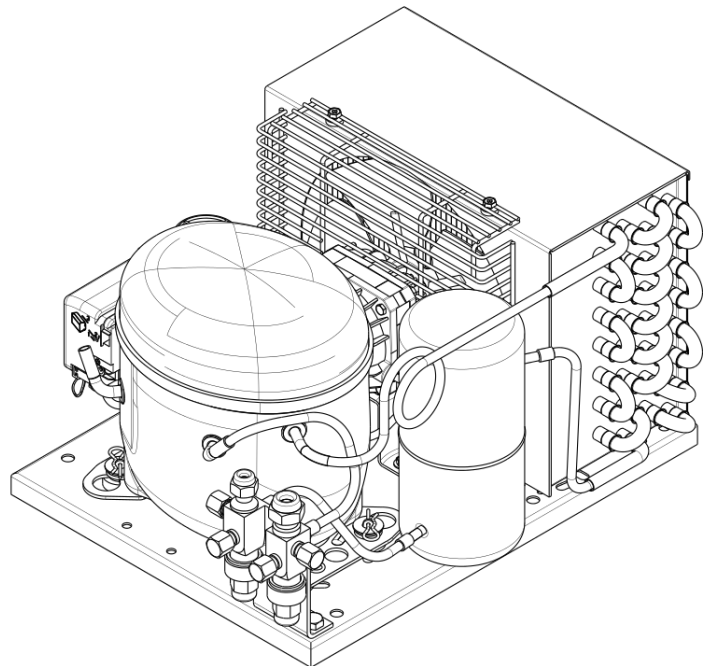
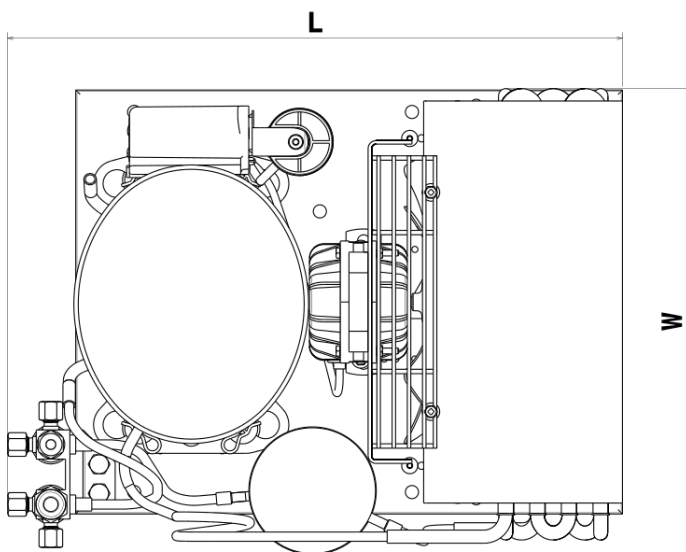
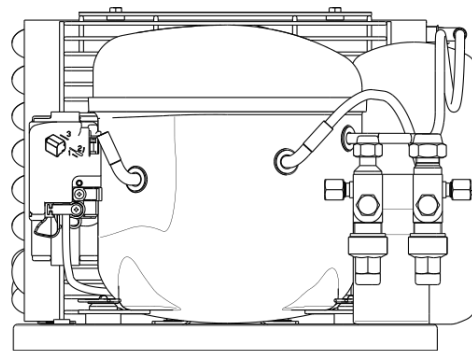
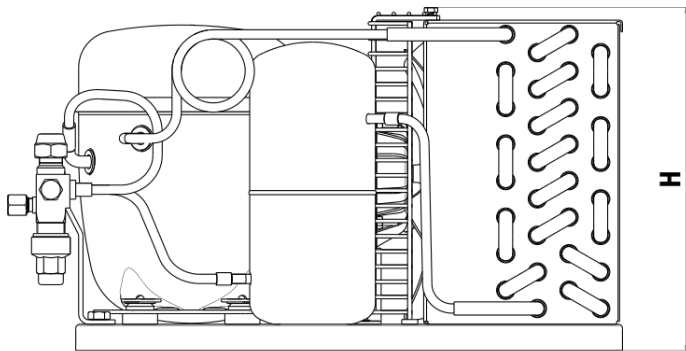

VERSION 1-4 (WxLxH) (mm)	VERSION 2 (WxLxH) (mm)	VERSION 3 (WxLxH) (mm)	VERSION 3P (WxLxH) (mm)
345x385x275	345x425x275	345x425x275	350x435x275