

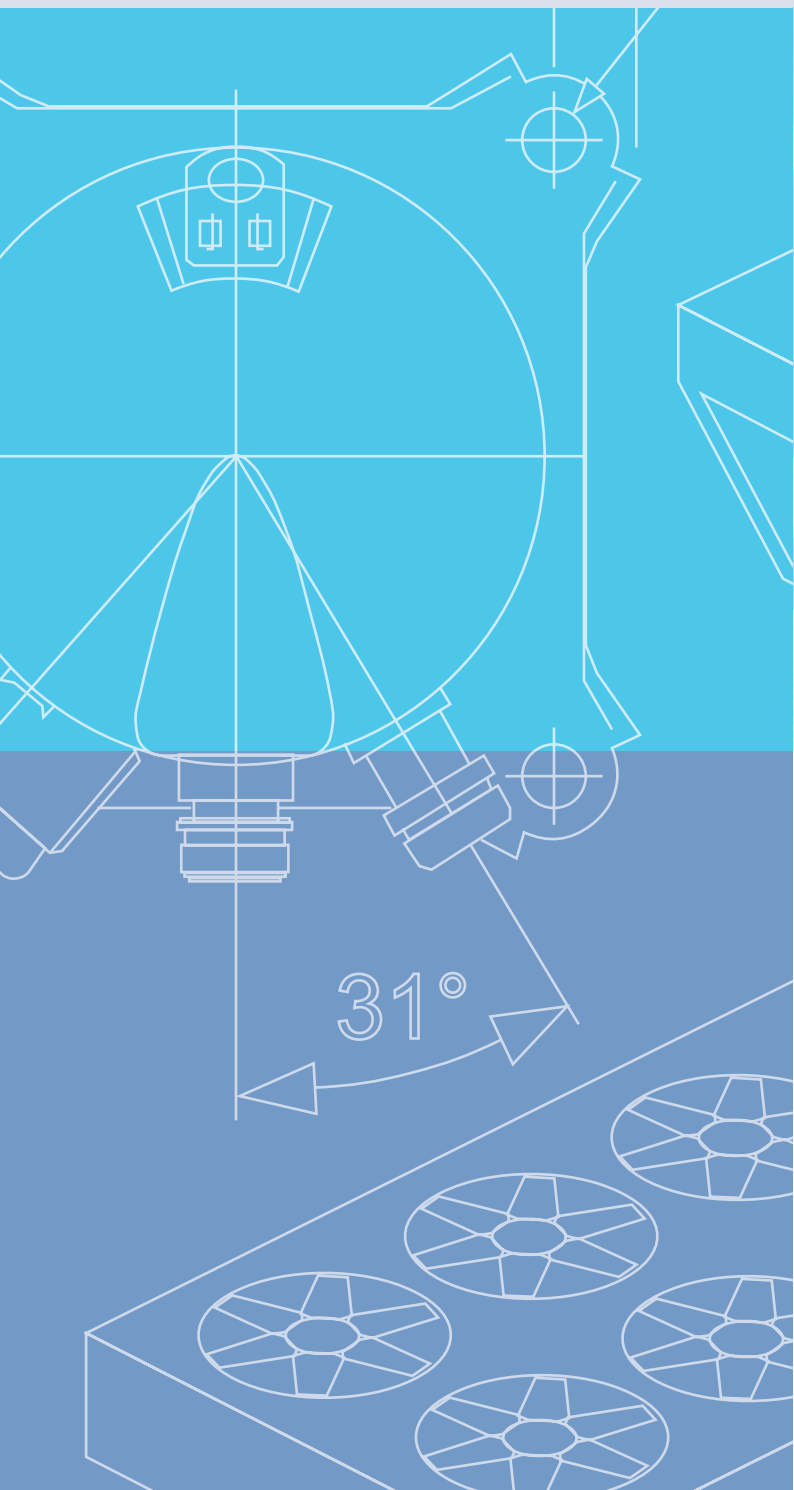

Scroll Compressors for Heat Pump Applications

ZH12K4E to ZH11M4E, ZH09KVE to ZH48KVE



About this guideline	1
1 Safety instructions	1
1.1 Icon explanation	1
1.2 Safety statements	1
1.3 General instructions	2
2 Product description	3
2.1 Common information about Copeland Scroll™ compressors.....	3
2.2 Nomenclature.....	3
2.3 Application range	4
2.3.1 <i>Qualified refrigerants and oils</i>	4
2.3.2 <i>Application limits and operating envelope</i>	4
2.3.3 <i>Dimensions</i>	5
3 Installation	7
3.1 Compressor handling	7
3.1.1 <i>Transport and storage</i>	7
3.1.2 <i>Positioning and securing</i>	7
3.1.3 <i>Installation location</i>	7
3.1.4 <i>Mounting parts</i>	8
3.2 Brazing procedure.....	8
3.3 Accumulators	9
3.4 Screens	10
3.5 Mufflers.....	10
3.6 Sound shell	10
3.7 Reversing valves.....	10
3.8 Suction line noise and vibration	11
4 Electrical connection	12
4.1 General recommendations	12
4.2 Electrical installation	12
4.2.1 <i>Terminal box</i>	14
4.2.2 <i>Motor windings</i>	15
4.2.3 <i>Protection devices</i>	15
4.2.4 <i>Crankcase heaters</i>	15
4.3 Pressure safety controls	16
4.3.1 <i>High-pressure control</i>	16
4.3.2 <i>Low-pressure control</i>	16
4.4 Discharge temperature protection.....	16
4.5 Motor protection	17
4.6 Protector functional check and failure detection	17
4.6.1 <i>Checking the connection</i>	18
4.6.2 <i>Checking the compressor thermistor chain</i>	18

4.6.3	Checking the protection module	18
4.7	High-potential testing.....	18
5	Starting up & operation.....	19
5.1	Strength pressure test	19
5.2	Tightness/pressure test	19
5.3	Preliminary checks – Pre-starting	19
5.4	Charging procedure.....	19
5.5	Run-in time	20
5.6	Initial start-up	20
5.7	Rotation direction	20
5.8	Starting sound.....	20
5.9	Deep vacuum operation	21
5.10	Shell temperature.....	21
5.11	Pump down cycle	21
5.12	Minimum run time.....	21
5.13	Shut-off sound.....	21
5.14	Supply frequency and voltage	21
5.15	Oil level.....	22
6	Maintenance & repair.....	23
6.1	Exchanging the refrigerant	23
6.2	Rotalock valves	23
6.3	Replacing a compressor.....	23
6.3.1	Compressor replacement.....	23
6.3.2	Start-up of a new or replacement compressor	23
6.4	Lubrication and oil removal.....	24
6.5	Oil additives	24
6.6	Unbrazing system components.....	25
7	Dismantling & disposal.....	25
8	References.....	25

About this guideline

The purpose of this guideline is to support Emerson ZH Scrolls users applying compressors in their systems. It intends to answer the questions raised while designing and assembling a system with these products.

Besides the support it provides, the instructions listed in this document are also critical for the good and safe functioning of the compressor. Emerson cannot guarantee the performance and reliability of the product if it is misused in regard of this guideline.

1 Safety instructions







Copeland Scroll™ compressors are manufactured according to the latest European and US safety standards. Particular emphasis has been placed on the user's safety.

These compressors are intended for installation in systems according to the EC Machines directive. They may be put to service only if they have been installed in these systems according to instructions and conform to the corresponding provisions of legislation. For relevant standards please refer to Manufacturers Declaration, available on request.

These instructions should be retained throughout the lifetime of the compressor.

You are strongly advised to follow these safety instructions.

1.1 Icon explanation

 <p>WARNING This icon indicates instructions to avoid personal injury and material damage.</p>	 <p>CAUTION This icon indicates instructions to avoid property damage and possible personal injury.</p>
 <p>High voltage This icon indicates operations with a danger of electric shock.</p>	 <p>IMPORTANT This icon indicates instructions to avoid malfunction of the compressor.</p>
 <p>Danger of burning or frostbite This icon indicates operations with a danger of burning or frostbite.</p>	<p>NOTE This word indicates a recommendation for easier operation.</p>
 <p>Explosion hazard This icon indicates operations with a danger of explosion.</p>	

1.2 Safety statements

- Refrigerant compressors must be employed only for their intended use.
- Only qualified and authorized HVAC or refrigeration personnel are permitted to install commission and maintain this equipment.
- Electrical connections must be made by qualified electrical personnel.
- All valid standards for connecting electrical and refrigeration equipment must be observed.



Use personal safety equipment. Safety goggles, gloves, protective clothing, safety boots and hard hats should be worn where necessary.

1.3 General instructions



WARNING

System breakdown! Personal injuries! Never install a system in the field and leave it unattended when it has no charge, a holding charge, or with the service valves closed without electrically locking out the system.

System breakdown! Personal injuries! Only approved refrigerants and refrigeration oils must be used.



WARNING

High shell temperature! Burning! Do not touch the compressor until it has cooled down. Ensure that other materials in the area of the compressor do not get in touch with it. Lock and mark accessible sections.



CAUTION

Overheating! Bearing damage! Do not operate compressors without refrigerant charge or without being connected to the system.



IMPORTANT

Transit damage! Compressor malfunction! Use original packaging. Avoid collisions and tilting.



CAUTION

Contact with POE! Material damage! POE must be handled carefully and the proper protective equipment (gloves, eye protection, etc.) must be used when handling POE lubricant. POE must not come into contact with any surface or material that might be harmed by POE, including without limitation, certain polymers (e.g. PVC/CPVC and polycarbonate).

2 Product description

2.1 Common information about Copeland Scroll™ compressors

The Scroll compressor has been under development at Emerson Climate Technologies since 1979. It is the most efficient and durable compressor Emerson Climate Technologies has ever developed for air conditioning, refrigeration and heating applications.

This application guideline deals with all vertical single Copeland Scroll™ compressors for dedicated heat pump applications from ZH12K4E to ZH11M4E, and also includes vapour injection compressors from ZH09KVE to ZH48KVE.

Compressor	Heating capacity kW	Motor
ZH12K4E	3.68	PFZ
ZH15K4E	4.77	PFJ/TFD
ZH21K4E	6.50	PFJ/TFD/TFR
ZH26K4E	8.19	PFJ/TFD/TFR
ZH30K4E	9.45	PFJ/TFD/TFR
ZH38K4E	11.65	PFZ/TFD/TFR
ZH45K4E	13.95	TFD
ZH56K4E	17.40	TWD/TFR
ZH75K4E	24.20	TWD/TFR
ZH92K4E	30.70	TWD/TFR
ZH11M4E	37.00	TWD/TFR

Compressor	Heating capacity kW	Motor
ZH09KVE	8.22	TFD/PFZ
ZH13KVE	11.85	TFD/PFJ
ZH18KVE	16.7	TFD
ZH24KVE	21.3	TWD
ZH33KVE	29.5	TWD
ZH40KVE	37	TWD
ZH48KVE	44.7	TWD

Evaporating temperature: -7°C; Condensing temperature: 50°C; Suction gas superheat: 5 K; Liquid sub-cooling: 4 K

These compressors have one Scroll compression set driven by a single- or three-phase induction motor. The Scroll set is mounted at the upper end of the rotor shaft of the motor. The rotor shaft axis is in the vertical plane.

2.2 Nomenclature

The model designation contains the following technical information about the standard and vapour injection compressors:

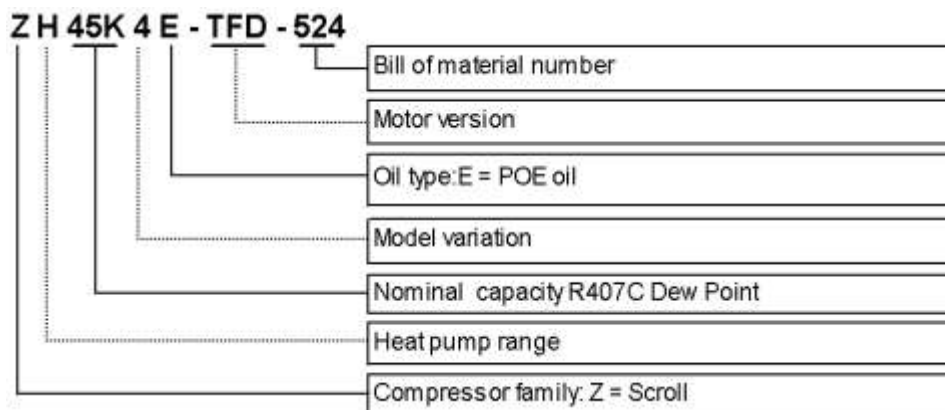

2.3 Application range

2.3.1 Qualified refrigerants and oils



IMPORTANT

It is essential that the glide of refrigerant blends (primarily R407C) is carefully considered when adjusting pressure and superheat controls.

Oil recharge values can be taken from Copeland Scroll™ compressors brochures or Copeland® brand products Selection Software.

Compressors	ZH12K4E – ZH11M4E	ZH09KVE – ZH48KVE
Qualified refrigerants	R407C, R134a	R407C
Copeland® brand products standard oil	Emkarate RL 32 3MAF	
Servicing oils	Emkarate RL 32 3MAF, Mobil EAL Arctic 22 CC	

Table 1: Qualified refrigerants and oils

2.3.2 Application limits and operating envelope



CAUTION

Inadequate lubrication! Compressor breakdown! Copeland Scroll™ compressors are qualified for operation inside the envelope published by Emerson Climate Technologies. The envelope is defined according to Emerson Climate Technologies testing and experience. Operating a compressor outside the envelope might lead to compressor failure which would be the heat pump manufacturer's responsibility. The superheat at the compressor suction inlet must always be sufficient to ensure that no refrigerant droplets enter the compressor. For a typical evaporator-expansion valve configuration a minimum stable superheat of at least 5K is required. In the same way, the superheat at the compressor suction must always stay below a maximum limit specified by Emerson Climate Technologies, depending on the model and for which the operating envelope is defined.

NOTE: The application envelopes shown below are for R407C only. For other refrigerant application envelopes, please refer to Copeland® brand products Selection Software found at www.emersonclimate.eu.

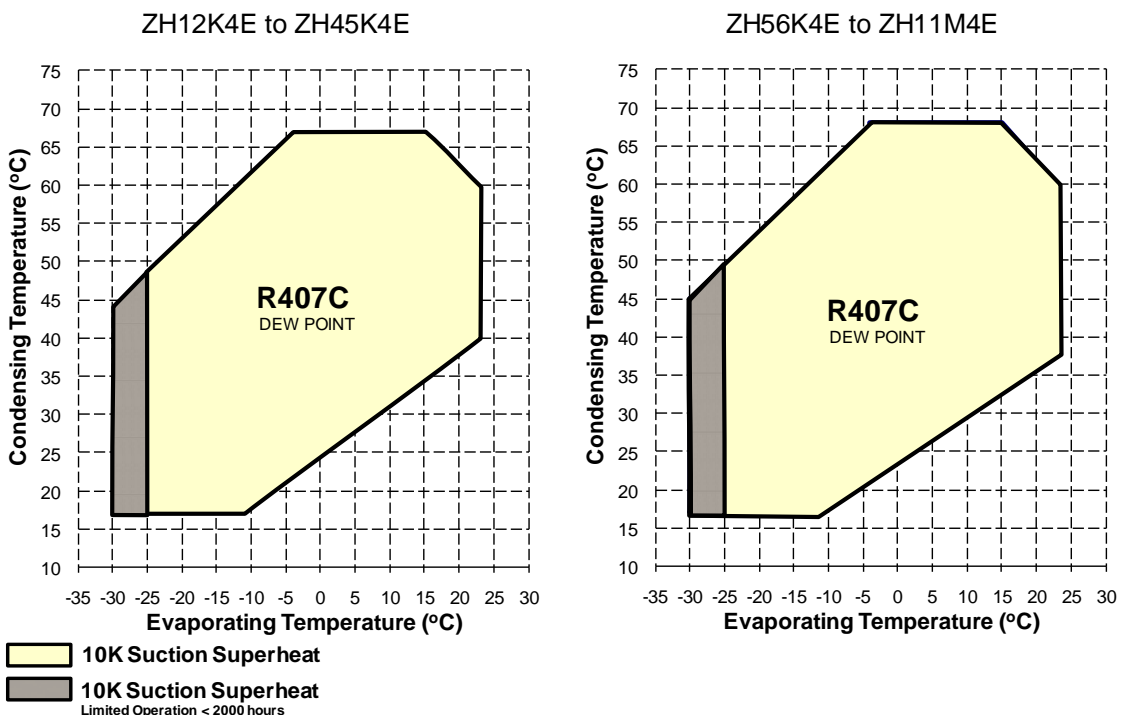

Figure 1: R407C application envelopes for standard compressors ZH12K4E to ZH11M4E

ZH09KVE to ZH48KVE

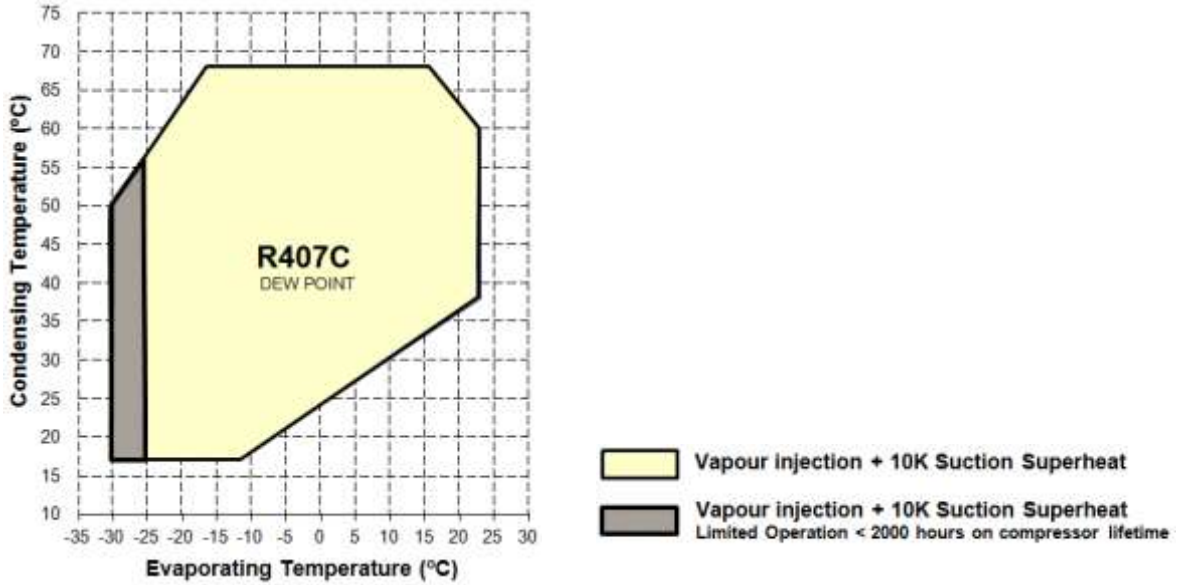
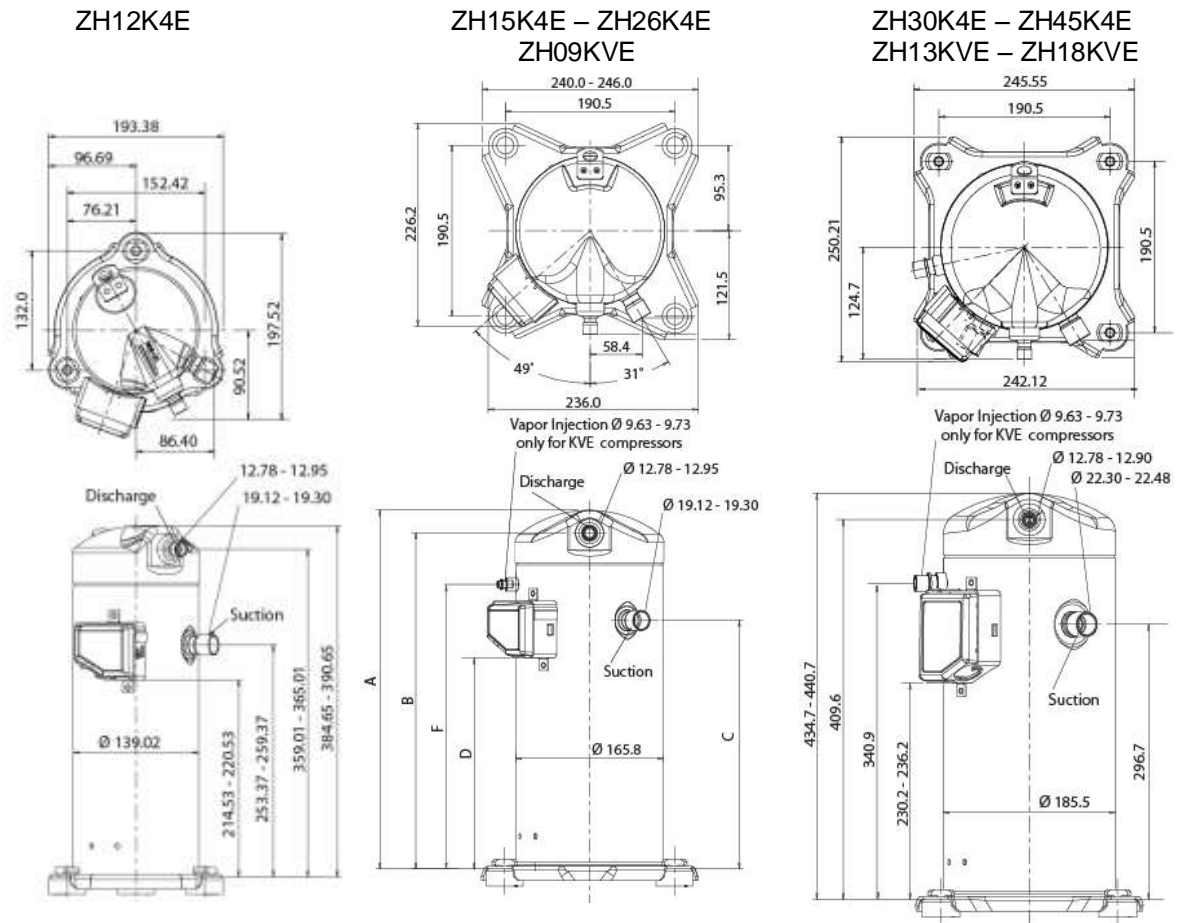

Figure 2: R407C application envelope for vapour injection compressors ZH09KVE to ZH48KVE operating with vapour injection

NOTE: For information regarding vapour injection, as well as the way to handle it, please refer to Technical Information C.7.4.3 “Vapour injection Scroll compressors for heat pumps”.

2.3.3 Dimensions



MODEL	A ± 3.0	B	C	D ± 3.0	F (only for KVE)
ZH26K4E	400.2	374.6	277.1	235.5	
ZH15K4E	363.8	338.8	244.5	202.9	
ZH19/21K4E, ZH09KVE	386.4	360.9	264.4	222.8	301.97

ZH56K4E – ZH92K4E
ZH24KVE – ZH40KVE

ZH11M4E
ZH48KVE

Vapor Injection Ø16
only for KVE compressors

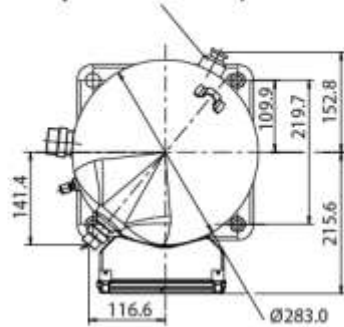

Vapor Injection Ø 16
only for KVE compressors

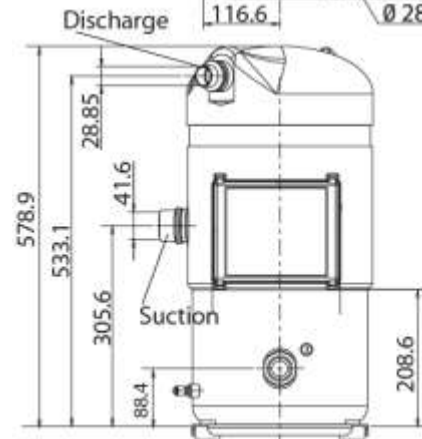
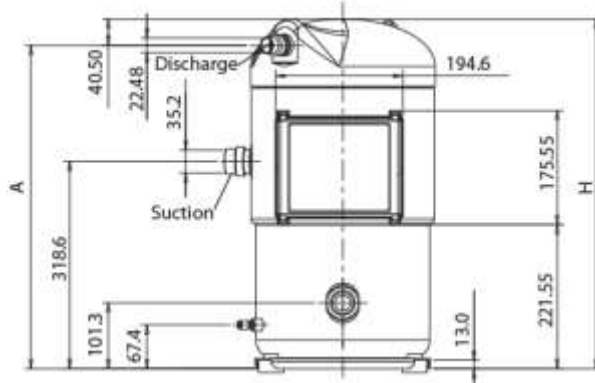
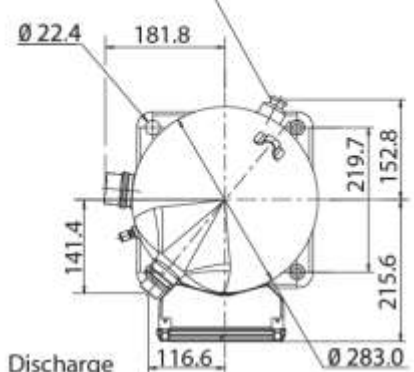

MODEL	A	H
ZH56K4E		
ZH75K4E	497.34	537.84
ZH24KVE		
ZH33KVE		
ZH92K4E	504.96	545.46
ZH40KVE		

3 Installation



WARNING

High pressure! Injury to skin and eyes possible! Be careful when opening connections on a pressurized item.

3.1 Compressor handling

3.1.1 Transport and storage



WARNING

Risk of collapse! Personal injuries! Move compressors only with appropriate mechanical or handling equipment according to weight. Keep in the upright position. Stack pallets on top of each other when not exceeding 300 kg. Do not stack single boxes on top of each other. Keep the packaging dry at all times.

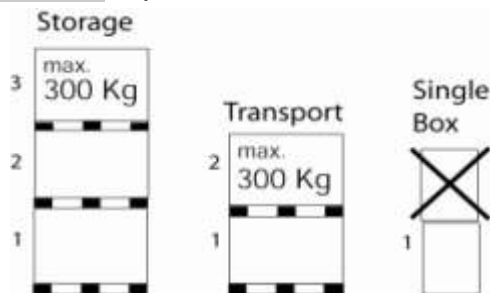

Figure 3

The compressor tilt angle should not be more than 30° during transport and handling. This will prevent oil from exiting through the suction stub. A tilt angle of maximum 45° is allowed for a very short time. Tilting the compressor more than 45° might affect its lubrication at start-up.

3.1.2 Positioning and securing



IMPORTANT

Handling damage! Compressor malfunction! Only use the lifting eyes whenever the compressor requires positioning. Using discharge or suction connections for lifting may cause damage or leaks.

The compressor should be kept as vertical as possible during handling. The discharge connection plug should be removed first before pulling the suction connection plug to allow the dry air pressure inside the compressor to escape. Pulling the plugs in this sequence prevents oil mist from coating the suction tube making brazing difficult. The copper-coated steel suction tube should be cleaned before brazing. No object, e.g., a swaging tool should be inserted deeper than 51 mm into the suction tube or it might damage the suction screen and motor.

Because oil might spill out of the suction connection located low on the shell, the suction connection plug must be left in place until the compressor is set into the unit.

The discharge connection plug should be removed first before pulling the suction connection plug to allow the dry air pressure inside the compressor to escape. Pulling the plugs in this sequence prevents oil mist from coating the suction tube making brazing difficult. The copper suction tube should be cleaned before brazing.

The plugs have to be removed as late as possible before brazing so that the air humidity does not affect the oil characteristics.

3.1.3 Installation location

Ensure the compressors are installed on a solid level base. Scroll compressors are capable of operating correctly in ambient air temperatures from -40°C to 60°C, ambient humidity from 30% to 95% and at altitudes up to 1000 meters.

For single compressor application, the compressor tilt angle during operation should not be more than 15° to allow adequate lubrication. For multiple compressor parallel configurations, the compressors must be positioned completely vertically on a totally horizontal surface or rail.

3.1.4 Mounting parts

Four vibration absorber grommets are supplied with each compressor. They dampen the start-up surge of the compressor and minimise sound and vibration transmission to the compressor base during operation. The metal sleeve inside is a guide designed to hold the grommet in place. It is not designed as a load-bearing member, and application of excessive torque to the bolts can crush the sleeve. Its inner diameter is approximately 8.5 mm to fit, e.g., an M8 screw. The mounting torque should be 13 ± 1 Nm. It is critically important that the grommet is not compressed.

If the compressors are mounted in tandem or used in parallel, then the hard mountings (bolt M9 5/16") are recommended. The mounting torque should be 27 ± 1 Nm. It is possible to deliver these hard mounting parts as a kit, or on request to deliver the compressor with these parts instead of the rubber grommets.

NOTE: For more information please refer to Technical Information C.7.11.2 "Scroll Mounting Parts".



Figure 4

3.2 Brazing procedure

IMPORTANT

Blockage! Compressor breakdown! Maintain a flow of oxygen-free nitrogen through the system at very low pressure during brazing. Nitrogen displaces the air and prevents the formation of copper oxides in the system. If allowed to form, the copper oxide material can later be swept through the system and block screens such as those protecting capillary tubes, thermal expansion valves, and accumulator oil return holes.

Contamination or moisture! Bearing failure! Do not remove the plugs until the compressor is set into the unit. This minimises any entry of contaminants and moisture.

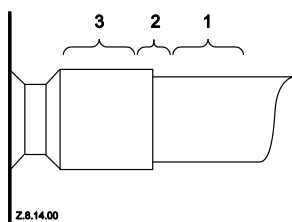

Figure 5: Suction tube brazing

Copeland Scroll™ compressors have copper-plated steel suction and discharge tubes. These tubes are far more robust and less prone to leaks than copper tubes. Due to the different thermal properties of steel and copper, brazing procedures may have to be changed from those commonly used.

Figure 5 shows the proper procedure for brazing the suction and discharge lines to a Scroll compressor.

- The copper-coated steel tubes on Scroll compressors can be brazed in approximately the same manner as any copper tube.
- Recommended brazing materials: any Silfos material is recommended, preferably with a minimum of 5% silver. However, 0% silver is acceptable.
- Be sure tube fitting inner diameter and tube outer diameter are clean prior to assembly.
- Using a double-tipped torch, apply heat in area 1.
- As the tube approaches brazing temperature, move the torch flame to area 2.
- Heat area 2 until braze temperature is attained, moving the torch up and down and rotating around the tube as necessary to heat the tube evenly. Add braze material to the joint while moving the torch around the joint to flow braze material around the circumference.
- After the braze material flows around the joint, move the torch to heat area 3. This will draw the braze material down into the joint. The time spent heating area 3 should be minimal.
- As with any brazed joint, overheating may be detrimental to the final result.

To disconnect:

- Heat joint areas 2 and 3 slowly and uniformly until the braze material softens and the tube can be pulled out of the fitting.

To reconnect:

- Recommended brazing materials: Silfos with minimum 5% silver or silver braze used on other compressors. Due to the different thermal properties of steel and copper, brazing procedures may have to be changed from those commonly used.

NOTE: Since the discharge stub contains a check valve, care must be taken not to overheat it to prevent brazing material from flowing into it.

3.3 Accumulators



CAUTION

Inadequate lubrication! Bearing and moving parts destruction! Minimise liquid refrigerant returning to the compressor. Too much refrigerant dilutes the oil. Liquid refrigerant can wash the oil off the bearings and moving parts leading to overheating and compressor failure.

Due to Copeland Scrolls inherent ability to handle liquid refrigerant in flooded start and defrost cycle operation, an accumulator is not required for durability in most systems. However, large volumes of liquid refrigerant repeatedly flooding back to the compressor during normal off cycles, or excessive liquid refrigerant flooding back during defrost or varying loads can dilute the oil, no matter what the system charge is. As a result, bearings and moving parts will be inadequately lubricated and wear may occur.

To determine if the accumulator can be removed, dedicated tests must be carried out to ensure that excessive liquid does not flood back to the compressor during defrost or varying loads. The defrost test must be done at an outdoor ambient temperature of around 0°C in a high relative humidity environment. Liquid floodback must be monitored during reversing valve operation, especially when coming out of defrost. Excessive floodback occurs when the sump temperature drops below the safe operation line shown in **Figure 6**.

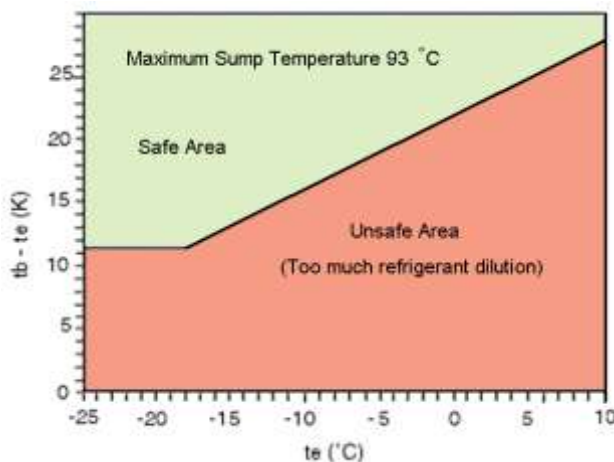

Figure 6: Dilution chart for transient operation (tb = bottom shell temp.; te = evaporating dew temp.)



If an accumulator must be used, the oil-return orifice should be from 1 to 1.4 mm in diameter for models ZH12K4E to ZH45K4E and ZH09KVE to ZH18KVE, and 2.0 mm for models ZH56K4E to ZH11M4E and ZH24KVE to ZH48KVE, depending on compressor size and compressor floodback results. To protect this small orifice from plugging with system debris a large-area protective screen no finer than 30 x 30 mesh (0.6 mm openings) is required. Tests have shown that a small screen with a fine mesh can easily become plugged causing oil starvation to the compressor bearings.

The size of the accumulator depends upon the operating range of the system and the amount of subcooling and subsequent head pressure allowed by the refrigerant control. System modelling indicates that heat pumps that operate down to and below -18°C will require an accumulator that can hold around 70% to 75% of the system charge.

3.4 Screens



CAUTION

Screen blocking! Compressor breakdown! Use screens with at least 0.6 mm openings.

The use of screens finer than 30 x 30 meshes (0.6 mm openings) anywhere in the system should be avoided with these compressors. Field experience has shown that finer mesh screens used to protect thermal expansion valves, capillary tubes or accumulators can become temporarily or permanently plugged with normal system debris and block the flow of either oil or refrigerant to the compressor. Such blockage can result in compressor failure.

3.5 Mufflers

External mufflers, normally applied to piston compressors in the past, may not be required for Copeland Scroll™ compressors.

Individual system tests should be performed to verify acceptability of sound performance. If adequate attenuation is not achieved, use a muffler with a larger cross-sectional area to inlet area ratio. A ratio of 20:1 to 30:1 is recommended.

A hollow shell muffler will work quite well. Locate the muffler at minimum 15 to maximum 45 cm from the compressor for the most effective operation. The farther the muffler is placed from the compressor within these ranges, the more effective. Choose a muffler with a length of 10 to 15 cm.

3.6 Sound shell

The sound power is an important criteria in the development of heating units. The nominal sound power of each Copeland Scroll™ compressor model is available in the Copeland® brand products Selection Software for the rating condition.

In order to decrease the sound power of the compressor, Emerson Climate Technologies offers optional sound covers available for a large range of ZH products.

The crankcase heater (if required by the refrigerant charge) must be placed inside the sound shell. Using an Emerson qualified crankcase heater within a sound shell has been tested and approved by Emerson Climate Technologies.

NOTE: For more information please refer to Technical Information C.7.11.4 “Sound shell installation instructions for Scroll compressors”.

3.7 Reversing valves

Since Copeland Scroll™ compressors have a very high volumetric efficiency their displacements are lower than those of equivalent capacity reciprocating compressors. As a result, Emerson Climate Technologies recommends that the capacity rating on reversing valves be no more than 1.5 to 2 times the nominal capacity of the compressor in order to ensure proper operation of the reversing valve under all operating conditions.

The reversing valve solenoid should be wired so that the valve does not reverse when the system is shut off by the operating thermostat in the heating or cooling mode. If the valve is allowed to reverse at system shut off, suction and discharge pressures are reversed to the compressor. This results in a condition of system pressures equalising through the compressor which can cause the compressor to slowly rotate until the pressures equalise. This condition does not affect compressor durability but can cause unexpected sound after the compressor is turned off.

3.8 Suction line noise and vibration

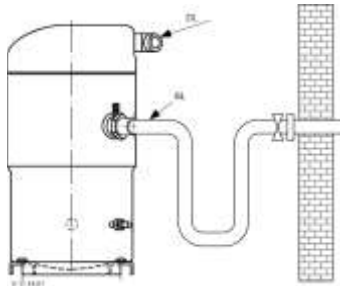

Figure 7: Suction tube design

Copeland Scroll™ compressors inherently have low sound and vibration characteristics. However in some respects, the sound and vibration characteristics differ from reciprocating compressors and in rare instances could result in unexpected sound generation. One difference is that the vibration characteristic of the Scroll compressor, although low, includes two very close frequencies, one of which is normally isolated from the shell by the suspension of an internally-suspended compressor. These frequencies, which are present in all compressors, may result in a low-level "beat" frequency that can be detected as noise coming along the suction line into the building under some conditions. Elimination of the beat can be achieved by attenuating all contributing

frequencies. This is easily done by using one of the common combinations of recommended design configurations. The scroll compressor makes both a rocking and twisting motion and enough flexibility must be provided in the line to prevent vibration transmission into any lines attached to the unit. In a split system, the most important goal is to ensure minimal vibration in all directions at the service valve to avoid transmitting vibrations to the structure to which the lines are fastened.

A second difference of the Copeland Scroll is that under some conditions the normal rotational starting motion of the compressor can transmit an "impact" noise along the suction line. This may be particularly pronounced in three-phase models due to their inherently higher starting torque. This phenomenon, like the one described previously, also results from the lack of internal suspension and can be easily avoided by using standard suction line isolation techniques as described below. The sound phenomena described above are not usually associated with reversible heat pump systems because of the isolation and attenuation provided by the reversing valve and tubing bends.

Recommended configuration

- Tubing configuration: small shock loop
- Service valve: "angled valve" fastened to unit / wall
- Suction muffler: not required

Alternative configuration

- Tubing configuration: small shock loop
- Service valve: "straight through" valve fastened to unit / wall
- Suction muffler: may be required (acts as dampening mass)

4 Electrical connection

4.1 General recommendations

The compressor terminal box has a wiring diagram on the inside of its cover. Before connecting the compressor, ensure the supply voltage, the phases and the frequency match the nameplate data.

4.2 Electrical installation

Recommended wiring diagrams are shown in figures hereunder.

NOTE: We recommend the use of a contactor K2 for the safety chain in order to comply with EN 60335.

Single-phase (PF*) compressors:

For the ZH12K4E to ZH38K4E and the ZH09KVE, ZH13KVE ranges of compressors the following circuit diagrams can be used:

Power circuit

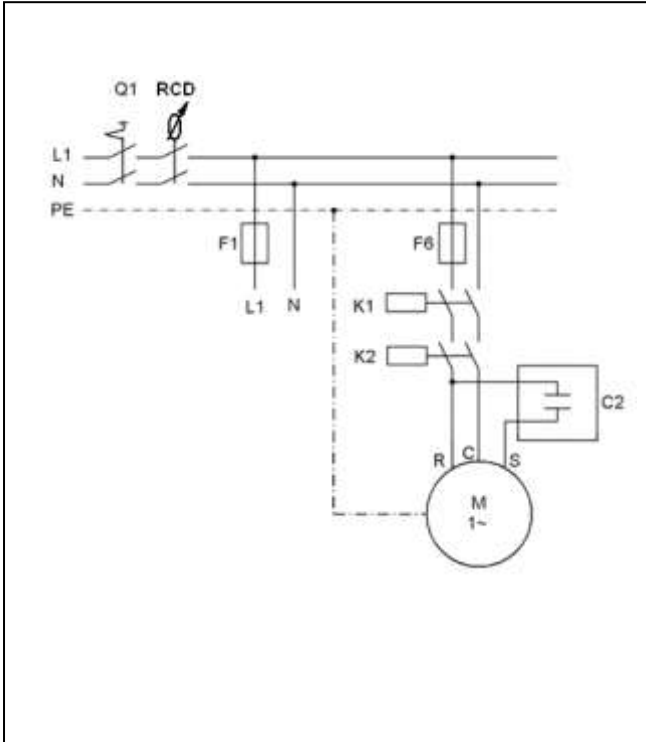

Control circuit

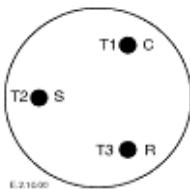
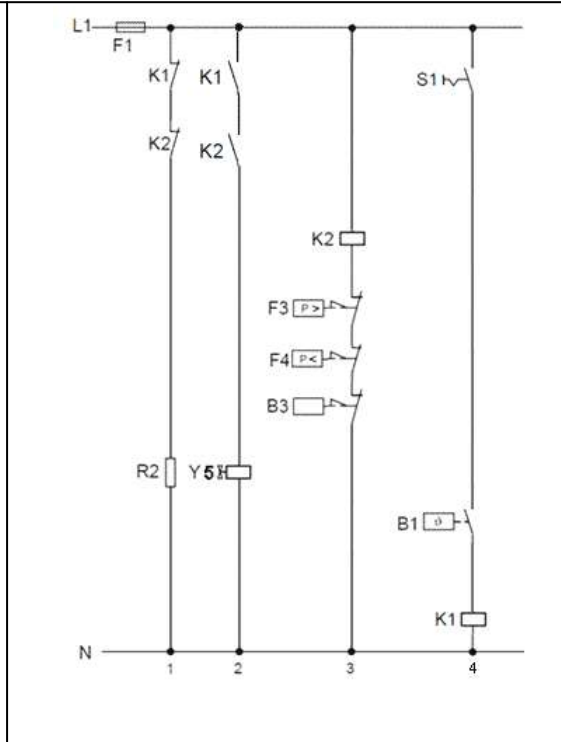

Motor terminal connections

Single-phase compressors are connected to the Common (C), Start (S) and Run (R) connections

Legend

B1.....Room thermostat
B3.....Discharge gas thermostat
C2.....Run capacitor
F1, F6..Fuses
F3.....HP switch
F4.....LP switch

K1, K2...Contactors
Q1.....Main switch
R2.....Crankcase heater
S1.....Auxiliary switch
Y5.....Solenoid valve for injection (if available)
RCD Residual current device

Figure 8

Three-phase compressors (TF*) with internal motor protection:

For the ZH15K4E to ZH45K4E and the ZH09KVE to ZH18KVE ranges of compressors the following circuit diagrams can be used:

Power circuit

Control circuit

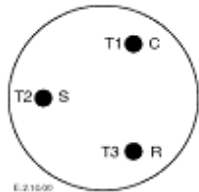
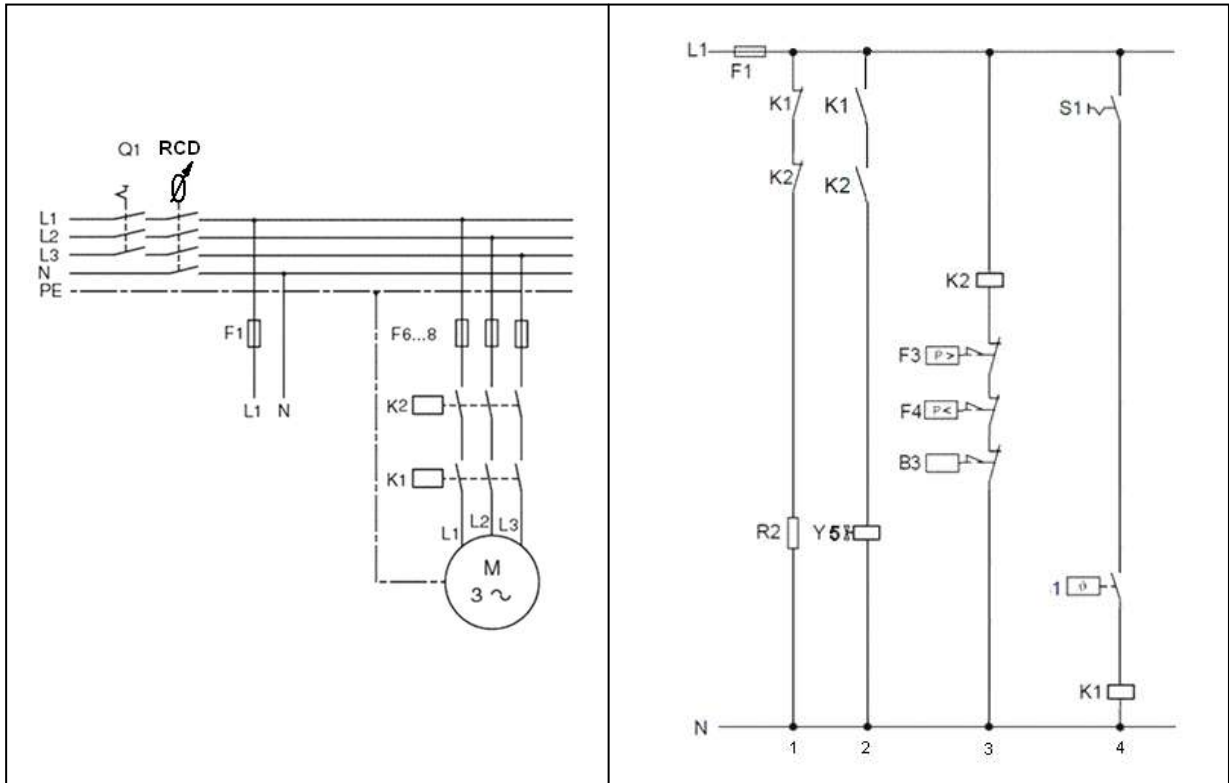

Motor terminal connections

Three-phase compressors are connected to the T1, T2 and T3 connections

Legend

- | | |
|---------------------------------|--|
| B1.....Room thermostat | Q1.....Main switch |
| B3.....Discharge gas thermostat | R2.....Crankcase heater |
| F1, F6, F8..Fuses | S1.....Auxiliary switch |
| F3.....HP switch | Y5.....Solenoid valve for injection (if available) |
| F4.....LP switch | RCD.....Residual current device |
| K1, K2.....Contactors | |

Figure 9

Three-phase compressors (TW*) with external motor protection INT69SC2:

For the ZH56K4E to ZH11M4E and the ZH24KVE to ZH48KVE ranges of compressors the following circuit diagrams can be used:

Power circuit

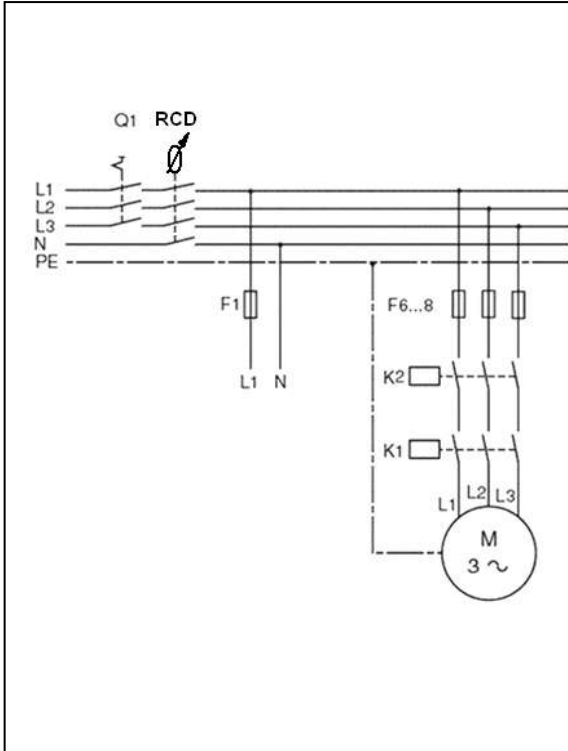

Control circuit

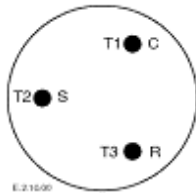
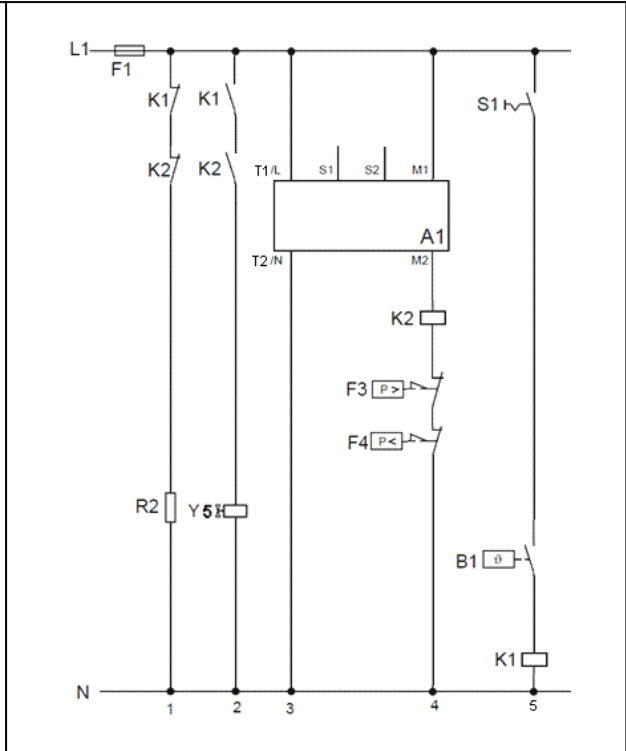

Motor terminal connections

Three-phase compressors are connected to the T1, T2 and T3 connections

Legend

- | | |
|--------------------------------|--|
| A1.....Motor protection module | Q1.....Main switch |
| B1.....Room thermostat | R2.....Crankcase heater |
| F1, F6, F8..Fuses | S1.....Auxiliary switch |
| F3.....HP switch | Y5.....Solenoid valve for injection (if available) |
| F4.....LP switch | RCD.....Residual current device |
| K1, K2.....Contactors | |

Figure 10

4.2.1 Terminal box

The terminal box is IP21 for all models without electronic motor protection (eg, TF*/PF*) and IP54 for all models with electronic motor protection (eg, TW*).

Maximum thickness of cable connectors for terminal box should be 1 mm for ZH30K4E to ZH45K4E and ZH13KVE to ZH18KVE compressors and 2 mm for ZH56K4E to ZH11M4E and ZH24KVE to ZH48KVE compressors (see **Figure 11**).

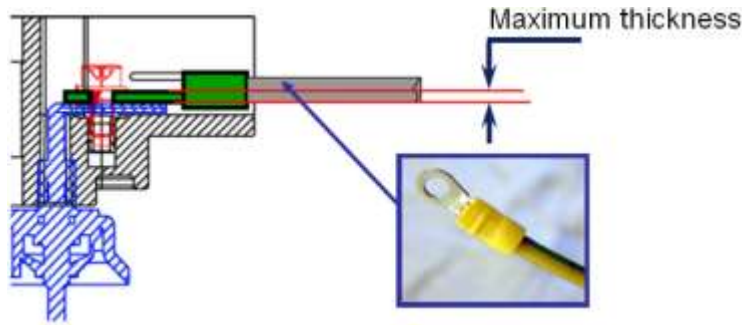

Figure 11

4.2.2 Motor windings

The ZH Scroll compressors are offered with either a single-phase or a three-phase induction motor, depending on the size. All three-phase motors are connected in star; single-phase motors need a run capacitor.

The motor insulation material is class "B" (PF* and TF*) or "H" (TW*) for compressor models covered in this guideline (maximum allowable operating temperatures 130°C (class B), 180°C (class H) according to IEC 34-1 or DIN 57530).

4.2.3 Protection devices

Independently from the internal motor protection, fuses must be installed before the compressor. The selection of fuses has to be carried out according to VDE 0635, DIN 57635, IEC 269-1 or EN 60-269-1.

4.2.4 Crankcase heaters

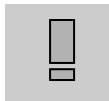

IMPORTANT

Oil dilution! Bearing malfunction! Turn the crankcase heater on 12 hours before starting the compressor.

A crankcase heater is required when the system charge exceeds the compressor charge limits listed in **Table 2**.

Model	Refrigerant charge limit
ZH12K4E	2.7 kg
ZH15K4E to ZH26K4E / ZH09KVE	3.6 kg
ZH30K4E to ZH45K4E / ZH13KVE to ZH18KVE	4.5 kg
ZH56K4E to ZH11M4E / ZH24KVE to ZH48KVE	7.5 kg

Table 2

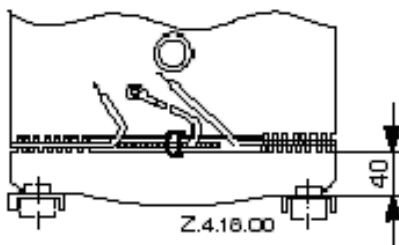

The crankcase heater must be mounted tight to the shell 40 mm above foot plate (see **Figure 12**).

Figure 12: Crankcase heater location

NOTE: The crankcase heater must be turned on a minimum of 12 hours prior to starting the compressor and must remain energised during compressor off cycles.

4.3 Pressure safety controls

4.3.1 High-pressure control

A high-pressure limiter should be installed according to EN 378.

4.3.2 Low-pressure control



IMPORTANT!

Loss of system charge and loss of lubrication! Bearing malfunction and compressor breakdown! A low-pressure control is highly recommended. Do not bridge or by-pass the low-pressure limiter.

Heat pumps in some geographical areas have to operate at low evaporating pressure because of the low ambient temperatures, sometimes combined with a high level of relative humidity. Good evaporator sizing and adequate defrost strategy control should prevent the system from operating outside the Emerson Climate Technologies published operating envelope, whatever the climatic conditions and the heating demand.

However, in some extreme cases – such as loss of system charge, extreme heat transfer restriction at the evaporator, any defect or blocked flow control component (expansion valve, screens, etc.) – the evaporating conditions may be such that the compressor tends to operate outside the Emerson Climate Technologies operating envelope limits. All those conditions may result in compressor failure.

Therefore, Emerson Climate Technologies strongly recommends the installation of a low pressure limiter in the suction line to stop the compressor when it operates outside the published envelope limits.

4.4 Discharge temperature protection



IMPORTANT!

Inadequate lubrication! Scroll set damage! Compressors ZH12K4E to ZH45K4E and ZH09KVE to ZH18KVE must be equipped with an external discharge temperature protection.

For ZH12K4E to ZH45K4E and ZH09KVE to ZH18KVE Scroll compressors, internal discharge temperatures reached under some extreme operating conditions (such as loss of charge or extremely high compression ratio) can cause compressor damage. In order to guarantee positive compressor protection, the compressor must be equipped with an external discharge temperature protection. This protection must not be used as an operating envelope limitation.

For compressors ZH12K4E to ZH45K4E the maximum discharge temperature is 140°C while for ZH09KVE to ZH18KVE compressors it is 130°C.

For compressors ZH56K4E to ZH11M4E and ZH24KVE to ZH48KVE, a thermistor is located in the discharge port of the fixed scroll. Excessive discharge temperature will cause the electronic protector module to trip. The discharge gas thermistor is wired in series with the motor thermistor chain.

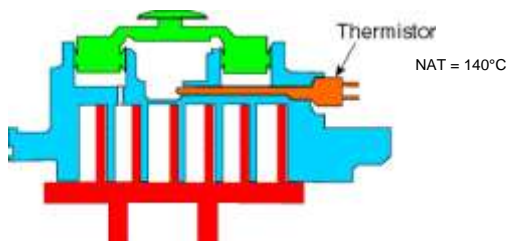

Figure 13: Internal discharge temperature sensor position for models ZH56K4E to ZH11M4E and ZH24KVE to ZH48KVE

4.5 Motor protection

For the ZH12K4E to ZH45K4E and the ZH09KVE to ZH18KVE ranges of compressors, conventional inherent internal line break motor protection is provided.

The electronic motor protection system used in all ZH56K4E to ZH11M4E and ZH24KVE to ZH48KVE models is identified by a "W" as the centre letter in the motor code. This system utilizes the temperature-dependent resistance of the thermistors (also called PTC-resistance) to read the winding temperature. A chain of four thermistors connected in series is embedded in the motor windings so that the temperature of the thermistors can follow the winding temperature with little inertia. An electronic module INT69SC2 is required to process the resistance values and trip a control depending on the thermistor resistance.

Protection module specifications

Type: Kriwan INT69SC2
Voltage: 115/120 V AC; 230/240 V AC – 50/60 Hz
Normal PTC resistance: $<1.8\text{ k}\Omega$
Trip resistance: $>4.50\text{ k}\Omega \pm 20\%$
Reset resistance: $<2.75\text{ k}\Omega \pm 20\%$
Module time out: 30 min \pm 5 min for ZH56K4E to ZH92K4E & ZH24KVE
to ZH40KVE
60 min \pm 5 min for ZH11M4E & ZH48KVE
Reset of running time: Power interruption / mains failure approx. 5 seconds
Phase monitor: No
Ambient temperature range: $-30^{\circ}\text{C} \dots +70^{\circ}\text{C}$

Module

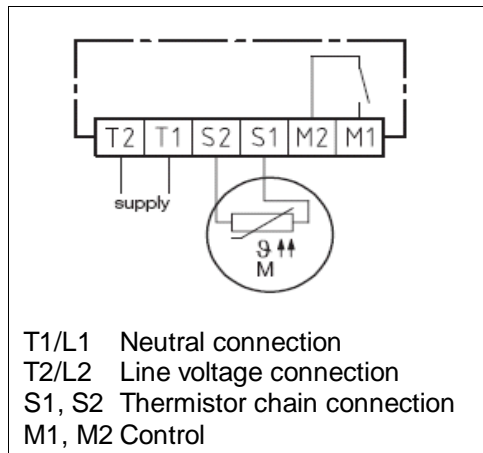

Figure 14: Wiring of the motor protection module

For protection in case of blocked rotor one thermistor for each phase is embedded in the winding heads on the upper (suction gas) side of the compressor motor. A fourth thermistor is located in a winding head at the lower end of the motor. A fifth sensor is located in the discharge port of the fixed scroll to control discharge-gas superheat. The entire chain is internally led to the fusite from where it is connected to the module connections S1 and S2. When any resistance of the thermistor chain reaches the tripping value, the module interrupts the control line and causes the compressor to switch off. After the thermistor has cooled sufficiently, its resistance drops to the reset value but the module itself resets after module time out then restarts the compressor.

4.6 Protector functional check and failure detection



WARNING

Conductor cables! Electrical shock! Shut off power supply before and between each test.

Prior to start-up of the fully connected compressor a functional check shall be carried out:

- Disconnect one terminal either S1 or S2 of the protection module. If the compressor is now switched on, the motor should not start (simulation of an open thermistor chain).
- Reconnect the disconnected thermistor line. If the compressor is now switched on, the motor must start.

If the motor does not start up during the functional check, this indicates a disturbance in operation. The following steps should be followed:

4.6.1 Checking the connection

- Check the connection of the thermistor leads in the terminal box and at the protection module for possible loose connections or cable breakage.

If there is neither loose connection nor cable breakage the resistance of the thermistor chain must be checked.

4.6.2 Checking the compressor thermistor chain

Caution: Use maximum measuring voltage of 3V!

The thermistor leads at terminals S1 and S2 of the module shall be disconnected and the resistance measured between the leads. The resistance must be between 150 Ω and 1250 Ω .

- If the thermistor chain has a higher resistance (2750 Ω or higher), the motor temperature is still too high and it must be allowed to cool. Then measure again.
- If the resistance is below 30 Ω , the compressor has to be exchanged due to shorted sensor circuit.
- An infinite value indicates an open sensor circuit and the compressor has to be replaced.

If no defect is detected in the thermistor chain the module must be checked.

4.6.3 Checking the protection module

The control connections at M1 and M2 have to be removed and the switching conditions must be checked by an ohmmeter or signal buzzer:

- Simulation of a short circuit in the thermistor chain (0 Ω): Bridge the already disconnected thermistor terminals S1 and S2 and switch on the voltage supply; the relay must switch on then off again after a short period; connection established then interrupted between terminals M1 and M2.
- Simulation of an open thermistor chain (∞ Ω): Remove the jumper used for the short-circuit simulation and switch on the voltage supply; the relay remains switched off; no connection between terminals M1 and M2.

If one of the above conditions is not met, the module is defective and has to be exchanged.

NOTE: The function of the module should be tested each time the fuse in the control circuit breaks the power supply. This ensures the contacts did not stick.

4.7 High-potential testing



WARNING

Conductor cables! Electrical shock! Shut off power supply before high-potential testing.



CAUTION

Internal arcing! Motor destruction! Do not carry out high-voltage or insulation tests if the compressor housing is under vacuum.

Emerson Climate Technologies subjects all Scroll compressors to a high-voltage test after final assembly. Each motor phase winding is tested, according to EN 0530 or VDE 0530 part 1, at a differential voltage of 1000V plus twice the nominal voltage. Since high-voltage tests lead to premature ageing of the winding insulation further additional tests of that nature are not recommended.

If it has to be done for any reason, a lower voltage must be used. Disconnect all electronic devices, e.g., motor protection module, fan speed control, etc prior to testing.

5 Starting up & operation



WARNING

Diesel effect! Compressor destruction! The mixture of air and oil at high temperature can lead to an explosion. Avoid operating with air.



IMPORTANT

Oil dilution! Bearing malfunction! Turn the crankcase heater on 12 hours before starting the compressor.

5.1 Strength pressure test

The compressor has been strength-tested in the factory. It is not necessary for the customer to strength- or leak-test the compressor again although the compressor will normally be exposed to the testing made as part of system testing.

5.2 Tightness/pressure test



WARNING

High pressure! Personal injuries! Consider personal safety requirements and refer to test pressures prior to test.



WARNING

System explosion! Personal injuries! DO NOT USE other industrial gases.



CAUTION

System contamination! Bearing malfunction! Use only dry nitrogen or dried air for pressure testing.

If using dry air do not include the compressor in the pressure test – isolate it first. Never add refrigerant to the test gas (as leak indicator).

5.3 Preliminary checks – Pre-starting

Discuss details of the installation with the installer. If possible, obtain drawings, wiring diagrams, etc.

It is ideal to use a check-list but always check the following:

- Visual check of the electrics, wiring, fuses etc
- Visual check of the plant for leaks, loose fittings such as TXV bulbs etc
- Compressor oil level
- Calibration of HP & LP switches and any pressure actuated valves
- Check setting and operation of all safety features and protection devices
- All valves in the correct running position
- Pressure and compound gauges fitted
- Correctly charged with refrigerant
- Compressor electrical isolator location & position

5.4 Charging procedure



CAUTION

Low suction pressure operation! Compressor damage! Do not operate with a restricted suction. Do not operate with the low-pressure limiter bridged. Do not operate compressor at pressures that are not allowed by the operating envelope. Allowing the suction pressure to drop below the envelope limit for more than a few seconds may overheat scrolls and cause early drive bearing and moving parts damage.

The system should be liquid-charged through the liquid-receiver shut-off valve or through a valve in the liquid line. The use of a filter drier in the charging line is highly recommended. Because R407C is a blend and scrolls have discharge check valves, systems should be liquid-charged on



both the high and low sides simultaneously to ensure a positive refrigerant pressure is present in the compressor before it runs. The majority of the charge should be placed in the high side of the system to prevent bearing washout during first-time start on the assembly line.

5.5 Run-in time

Scroll compressors exhibit a slight decrease in input power during the initial running period. Published performance ratings are based on calorimeter testing which is carried out after run-in. Therefore users should be aware that before the performance specified by EN 12900 is achieved the compressor needs to be run-in. Typical run-in times required for ZH compressors to attain the published performance are 16 hours at the saturation dew evaporating and condensing temperatures condition $-7/50^{\circ}\text{C}$ with a superheat of 10K.

5.6 Initial start-up



CAUTION

Oil dilution! Bearing malfunction! It is important to ensure that new compressors are not subjected to liquid abuse. Turn the crankcase heater on 12 hours before starting the compressor.



CAUTION

High discharge pressure operation! Compressor damage! Do not use compressor to test opening set point of high-pressure limit. Bearings and moving parts are susceptible to damage before they have had several hours of normal running in.

Liquid and high pressure loads could be detrimental to new bearings. It is therefore important to ensure that new compressors are not subjected to liquid abuse and high-pressure run tests. It is not good practice to use the compressor to test the high-pressure switch function on the production line. Switch function can be tested with nitrogen prior to installation and wiring can be checked by disconnecting the high-pressure switch during the run test.

5.7 Rotation direction

Scroll compressors, like several other types of compressors, will only compress in one rotational direction. Direction of rotation is not an issue with single-phase compressors since they will always start and run in the proper direction. Three-phase compressors will rotate in either direction depending upon phasing of the power. Since there is a 50-50 chance of connecting power in such a way as to cause rotation in the reverse direction, **it is important to include notices and instructions in appropriate locations on the equipment to ensure proper rotation direction when the system is installed and operated.**

Observing that suction pressure drops and discharge pressure rises when the compressor is energized allows verification of proper rotation direction. There is no negative impact on durability caused by operating three-phase Copeland Scroll™ compressors in the reversed direction for a short period of time (under one hour) but oil may be lost. Oil loss can be prevented during reverse rotation if the tubing is routed at least 15 cm above the compressor. After several minutes of operation in reverse, the compressor protection system will trip due to high motor temperature. The operator will notice a lack of cooling or heating. However, if allowed to repeatedly restart and run in reverse without correcting the situation, the compressor will be permanently damaged.

All three-phase scroll compressors are identically wired internally. Therefore, once the correct phasing is determined for a specific system or installation, connecting properly phased power leads to the identified compressor terminals will ensure proper rotation direction.

5.8 Starting sound

During the very brief start-up, a clicking sound is audible, resulting from initial contacting of the spirals and is normal. Due to the design of the Copeland Scroll™ compressors, the internal compression components always start unloaded even if system pressures are not balanced. In addition, since internal compressor pressures are always balanced at start-up, low-voltage starting characteristics are excellent for Copeland Scroll™ compressors.

5.9 Deep vacuum operation



CAUTION

Vacuum operation! Compressor damage! Copeland Scroll™ compressors should never be used to evacuate refrigeration or air-conditioning systems.

The scroll compressor can be used to pump down refrigerant in a unit as long as the pressures remain within the operating envelope. Low suction pressures will result in overheating of the scrolls and permanent damage to the compressor drive bearing and moving parts.

5.10 Shell temperature

System component failure may cause the top shell and discharge line to briefly reach temperatures above 140°C. Wiring or other materials, which could be damaged by these temperatures, should not come in contact with the shell.

5.11 Pump down cycle

A pump down cycle for control of refrigerant migration may be used in conjunction with a crankcase heater when the compressor is located so that cold air blowing over the compressor makes the crankcase heater ineffective.

If a pump down cycle is used, a separate external check valve must be added. The scroll discharge check valve is designed to stop extended reverse rotation and prevent high-pressure gas from leaking rapidly into the low side after shut-off. The check valve will in some cases leak more than reciprocating compressor discharge reeds, normally used with pump down, causing the scroll compressor to recycle more frequently. Repeated short-cycling of this nature can result in a low oil situation and consequent damage to the compressor. The low-pressure control differential has to be reviewed since a relatively large volume of gas will re-expand from the high side of the compressor into the low side after shutdown.

Pressure control setting: Never set the low-pressure control to shut off outside of the operating envelope. To prevent the compressor from running into problems during such faults as loss of charge or partial blockage, the control should not be set lower than the minimum suction pressure allowed by the operating envelope.

5.12 Minimum run time

Emerson Climate Technologies recommends a maximum of 10 starts per hour. There is no minimum off time because scroll compressors start unloaded, even if the system has unbalanced pressures. The most critical consideration is the minimum run time required to return oil to the compressor after start-up. To establish the minimum run time obtain a sample compressor equipped with a sight tube (available from Emerson Climate Technologies) and install it in a system with the longest connecting lines that are approved for the system. The minimum on time becomes the time required for oil lost during compressor start-up to return to the compressor sump and restore a minimal oil level that will ensure oil pick-up through the crankshaft. Cycling the compressor for a shorter period than this, for instance to maintain very tight temperature control, will result in progressive loss of oil and damage to the compressor.

5.13 Shut-off sound

Scroll compressors incorporate a device that minimizes reverse rotation. The residual momentary reversal of the scrolls at shut off will cause a clicking sound, but it is entirely normal and has no effect on compressor durability.

5.14 Supply frequency and voltage

There is no general release of standard Copeland Scroll™ compressors for use with variable speed AC drives. There are numerous issues that must be considered when applying Scroll compressors with variable speed, including system design, inverter selection, and operating envelopes at various conditions.

The last digit of the model motor code indicates which frequency and voltage must be applied (see section 2.3 “Nomenclature”).



50 Hz	60 Hz	Code
380-420-3 ph	460-3 ph	D
220-240-1 ph	265-1 ph	J
380-420-3 ph	----	M
220-240-3 ph	----	R
220-240-1 ph	----	Z
200-220-3 ph	200-230-3 ph	5

Table 3: Typical ZH models electrical codes

For models allowing operation at 50 or 60 Hz (codes D, J and 5), only frequencies from 50 to 60 Hz are acceptable. Operation outside this frequency range is possible but should not be done without specific Application Engineering review. The voltage must vary proportionally to the frequency.

If the inverter can only deliver a maximum voltage of 400V, the amps will increase when the speed is above 50 Hz, and this may give rise to nuisance tripping if operation is near the maximum power limit and/or compressor discharge temperature limit.

5.15 Oil level

Compressor models ZH56K4E to ZH11M4E and ZH24KVE to ZH48KVE are equipped with an oil sight glass. In these models the oil level should be maintained at mid-point of the sight glass. If an oil regulator is used the level should be set within the top half of the sight glass.

During the heat pump development, adequate oil return in any operation should be checked, whatever the compressor model. For this purpose, compressor samples with sight tube can be ordered from Emerson Climate Technologies. Oil return check test recommendations are also available on demand from Application Engineering.

6 Maintenance & repair

6.1 Exchanging the refrigerant

Qualified refrigerants and oils are given in section 2.4.1.

It is not necessary to replace the refrigerant with new unless contamination due to an error such as topping up the system with an incorrect refrigerant is suspected. To verify correct refrigerant composition, a sample can be taken for chemical analysis. A check can be made during shut down by comparing the refrigerant temperature and pressure using precision measurements at a location in the system where liquid and vapour phases are present and when the temperatures have stabilised.

In the event that the refrigerant needs replacing, the charge should be recovered using a suitable recovery unit.

6.2 Rotalock valves

Rotalock valves should be periodically re-torqued to ensure that leak tightness is maintained.

6.3 Replacing a compressor



CAUTION

Inadequate lubrication! Bearing destruction! Exchange the accumulator after replacing a compressor with a burned out motor. The accumulator oil return orifice or screen may be plugged with debris or may become plugged. This will result in starvation of oil to the new compressor and a second failure.

6.3.1 Compressor replacement

In the case of a motor burnout, the majority of contaminated oil will be removed with the compressor. The rest of the oil is cleaned through the use of suction and liquid line filter driers. A 100% activated alumina suction line filter drier is recommended but must be removed after 72 hours. **It is highly recommended that the suction accumulator be replaced if the system contains one.** This is because the accumulator oil return orifice or screen may be plugged with debris or may become plugged shortly after a compressor failure. This will result in starvation of oil to the replacement compressor and a second failure. When a single compressor or tandem is exchanged in the field, it is possible that a major portion of the oil may still be in the system. While this may not affect the reliability of the replacement compressor, the extra oil will add to rotor drag and increase power usage.

6.3.2 Start-up of a new or replacement compressor

Rapid charging only on the suction side of a scroll-equipped system or condensing unit can occasionally result in a temporary no start condition for the compressor. The reason for this is that, if the flanks of the compressor happen to be in a sealed position, rapid pressurisation of the low side without opposing high-side pressure can cause the scrolls to seal axially. As a result, until the pressures eventually equalise, the scrolls can be held tightly together preventing rotation. The best way to avoid this situation is to charge on both the high and low sides simultaneously at a rate which does not result in axial loading of the scrolls.

A minimum suction pressure specified in the published operating envelope must be maintained during charging. Allowing the suction pressure to drop below that value may overheat the scrolls and cause early drive bearing and moving parts damage. Never install a system in the field and leave it unattended when it has no charge, a holding charge, or with the service valves closed without securely electrically locking out the system. This will prevent unauthorised personnel from accidentally operating the system and potentially ruining the compressor by operating with no refrigerant flow. **Do not start the compressor while the system is in a deep vacuum.** Internal arcing may occur when a Scroll compressor is started in a vacuum causing burnout of the internal lead connections.

6.4 Lubrication and oil removal



CAUTION

Chemical reaction! Compressor destruction! Do not mix up ester oils with mineral oil and/or alkyl benzene when used with chlorine-free (HFC) refrigerants.

The compressor is supplied with an initial oil charge. The standard oil charge for use with refrigerants R407C / R134a is a polyolester (POE) lubricant Emkarate RL 32-3MAF. In the field the oil level could be topped up with Mobil EAL Arctic 22 CC if 3MAF is not available. See nameplate for original oil charge shown in litres. A field recharge is from 0.05 to 0.1litre less.

One disadvantage of POE is that it is far more hygroscopic than mineral oil (see **Figure 15**). Only brief exposure to ambient air is needed for POE to absorb sufficient moisture to make it unacceptable for use in a refrigeration system. Since POE holds moisture more readily than mineral oil it is more difficult to remove it through the use of vacuum. Compressors supplied by Emerson Climate Technologies contain oil with low moisture content, and it may rise during the system assembling process. Therefore it is recommended that a properly sized filter-drier is installed in all POE systems. This will maintain the moisture level in the oil to less than 50 ppm. If oil is charged into a system, it is recommended to use POE with moisture content no higher than 50 ppm.

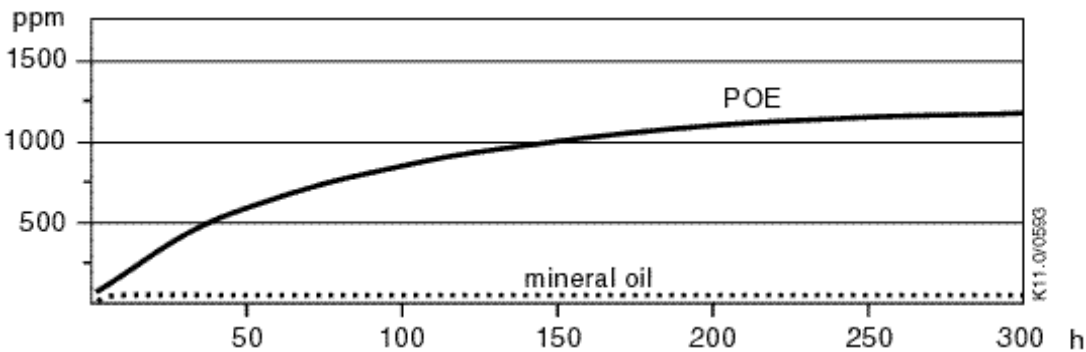

Figure 15: Absorption of moisture in ester oil in comparison to mineral oil in ppm by weight at 25° C and 50% relative humidity (h=hours)

If the moisture content of the oil in a refrigeration system reaches unacceptably high levels, corrosion and copper plating may occur. The system should be evacuated down to 0.3 mbar or lower. If there is uncertainty as to the moisture content in the system, an oil sample should be taken and tested for moisture. Sight glass/moisture indicators currently available can be used with the HFC refrigerants and lubricants; however, the moisture indicator will just show the moisture contents of the refrigerant. The actual moisture level of POE would be higher than the sight glass indicates. This is due to the high hygroscopicity of the POE oil. To determine the actual moisture content of the lubricant, samples have to be taken from the system and analysed.

6.5 Oil additives

Although Emerson Climate Technologies cannot comment on any specific product, from our own testing and past experience, we do not recommend the use of any additives to reduce compressor bearing losses or for any other purpose. Furthermore, the long term chemical stability of any additive in the presence of refrigerant, low and high temperatures, and materials commonly found in refrigeration systems is complex and difficult to evaluate without rigorously controlled chemical laboratory testing. The use of additives without adequate testing may result in malfunction or premature failure of components in the system and, in specific cases, in voiding the warranty on the component.

6.6 Unbrazing system components



WARNING

Explosive flame! Burning! Oil-refrigerant mixtures are highly flammable. Remove all refrigerant before opening the system. Avoid working with an unshielded flame in a refrigerant charged system.

Before opening up a system it is important to remove all refrigerant from both the high and low sides of the system. If the refrigerant charge is removed from a scroll-equipped unit from the high side only, it is possible for the scrolls to seal, preventing pressure equalization through the compressor. This may leave the low side shell and suction line tubing pressurized. If a brazing torch is then applied to the low side while the low side shell and suction line contain pressure, the pressurized refrigerant and oil mixture could ignite when it escapes and contacts the brazing flame. To prevent this occurrence, it is important to check both the high and low sides with manifold gauges before unbrazing. Instructions should be provided in appropriate product literature and assembly (line repair) areas. If compressor removal is required, the compressor should be cut out of system rather than unbrazed.

7 Dismantling & disposal



Removing oil and refrigerant:

Do not disperse in the environment.

Use the correct equipment and method of removal.

Dispose of oil and refrigerant properly.

Dispose of compressor properly.

8 References

- C7.11.2 “Mounting parts for Copeland Scroll™ compressors”
- C7.11.4 “Sound Shell Installation Instructions for for Copeland Scroll™ compressors”
- C7.4.3 “Vapour injection Scroll compressors for heat pumps”
- C7.17.3 “Paralleling of ZH Copeland Scroll™ compressors for heat pump applications”

ADDENDUM

1. The contents of this publication are presented for informational purposes only and are not to be construed as warranties or guarantees, express or implied, regarding the products or services described herein or their use or applicability.
2. Emerson Climate Technologies, Inc. and/or its affiliates (collectively "Emerson"), as applicable, reserve the right to modify the design or specifications of such products at any time without notice.
3. Emerson does not assume responsibility for the selection, use or maintenance of any product. Responsibility for proper selection, use and maintenance of any Emerson product remains solely with the purchaser or end user.

BENELUX

Deltakade 7
NL-5928 PX Venlo
Tel. +31 77 324 02 34
Fax +31 77 324 02 35
benelux.sales@emerson.com

UK & IRELAND

Unit 17, Theale Lakes Business Park
Reading, Berks RG7 4GB
Tel: +44 1189 83 80 00
Fax: +44 1189 83 80 01
uk.sales@emerson.com

BALKAN

Selska cesta 93
HR-10 000 Zagreb
Tel. +385 1 560 38 75
Fax +385 1 560 38 79
balkan.sales@emerson.com

GERMANY, AUSTRIA & SWITZERLAND

Senefelder Str. 3
DE-63477 Maintal
Tel. +49 6109 605 90
Fax +49 6109 60 59 40
ECTGermany.sales@emerson.com

SWEDEN, DENMARK, NORWAY & FINLAND

Pascalstr. 65
DE-52076 Aachen
Tel. +49 2408 929 0
Fax +49 2408 92 95 28
nordic.sales@emerson.com

UKRAINE

Turgenevskaya Str. 15, office 33
UA-01054, Kiev
Tel. +38 - 44 - 4 92 99 24
Fax. +38 - 44 - 4 92 99 28
Andrey.Gladchenko@emerson.com

FRANCE, GREECE & MAGHREB

8, Allée du Moulin Berger
FR-69130 Ecully Cédex
Tel. +33 4 78 66 85 70
Fax +33 4 78 66 85 71
mediterranean.sales@emerson.com

EASTERN EUROPE & TURKEY

Pascalstr. 65
DE-52076 Aachen
Tel. +49 2408 929 0
Fax +49 2408 929 525
easterneurope.sales@emerson.com

ROMANIA

Tel. +40 - 364 - 73 11 72
Fax. +40 - 364 - 73 12 98
Camelia.Tiru@emerson.com

ITALY

Via Ramazzotti, 26
IT-21047 Saronno (VA)
Tel. +39 02 96 17 81
Fax +39 02 96 17 88 88
italy.sales@emerson.com

POLAND

Szturmowa 2
PL-02678 Warsaw
Tel. +48 22 458 92 05
Fax +48 22 458 92 55
poland.sales@emerson.com

MIDDLE EAST & AFRICA

PO Box 26382
Jebel Ali Free Zone - South, Dubai - UAE
Tel. +971 4 811 81 00
Fax +971 4 886 54 65
mea.sales@emerson.com

SPAIN & PORTUGAL

C/ LLull, 321 (Edifici CINC)
ES-08019 Barcelona
Tel. +34 93 412 37 52
Fax +34 93 412 42 15
iberica.sales@emerson.com

RUSSIA & CIS

Letnikovskaya 10, Bld. 2, floor 5
RU-115114 Moscow
Tel. +7 495 981 98 11
Fax +7 495 981 98 16
ECT.Holod@emerson.com

For more details, see www.emersonclimate.eu

Emerson Climate Technologies - European Headquarters - Pascalstrasse 65 - 52076 Aachen, Germany
Phone: +49 (0) 2408 929 0 - Fax: +49 (0) 2408 929 570 - Internet: www.emersonclimate.eu

The Emerson Climate Technologies logo is a trademark and service mark of Emerson Electric Co. Emerson Climate Technologies Inc. is a subsidiary of Emerson Electric Co. Copeland is a registered trademark and Copeland Scroll is a trademark of Emerson Climate Technologies Inc. All other trademarks are property of their respective owners. Information contained in this brochure is subject to change without notification.

© 2011 Emerson Climate Technologies, Inc.



EMERSON
Climate Technologies

EMERSON. CONSIDER IT SOLVED.™