

Data sheet

Water valve Type WVO

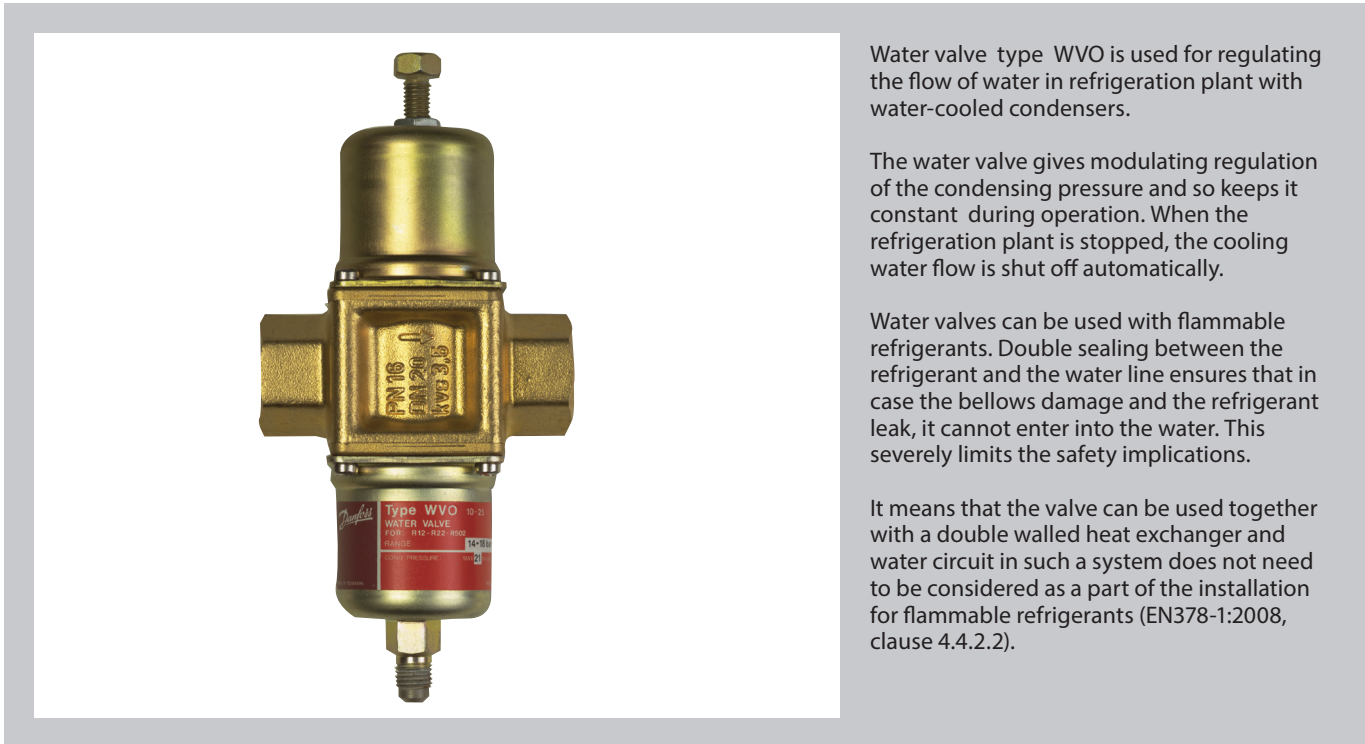

Water valve type WVO is used for regulating the flow of water in refrigeration plant with water-cooled condensers.

The water valve gives modulating regulation of the condensing pressure and so keeps it constant during operation. When the refrigeration plant is stopped, the cooling water flow is shut off automatically.

Water valves can be used with flammable refrigerants. Double sealing between the refrigerant and the water line ensures that in case the bellows damage and the refrigerant leak, it cannot enter into the water. This severely limits the safety implications.

It means that the valve can be used together with a double walled heat exchanger and water circuit in such a system does not need to be considered as a part of the installation for flammable refrigerants (EN378-1:2008, clause 4.4.2.2).

Features

- Compact valve,
- Setting pressure done by factory (optional),
- HCFC, HFC and HC,
- NPT threads on request,
- Capillary tube available as option,
- Stainless steel version available for request,
- Suitable for flammable refrigerants,
- Compliant with ATEX hazard zone 2.

Technical data

	Water side	Refrigerant side
Max. working pressure PS/MWP	16 bar/232 psig	26.4 bar/383 psig
Max. test pressure PT	24 bar/ 350 psig	38 bar/551 psig
Media	Fresh water and neutral brine	HCFC, HFC and HC
Max. differential pressure	10 bar/145 psi	—
Temperature range	-25 – 130 °C/-13 – 266 °F	

Type	Orifice size		k_v value ¹⁾	C_v value ²⁾
	[mm]	[in.]	[m ³ /h]	[gal/min]
WVO 10	10	2/5	1.4	1.6
WVO 15	15	3/5	1.9	2.2
WVO 20	20	4/5	3.4	3.9
WVO 25	25	1	5.5	6.4

¹⁾ The k_v value is the flow of water in [m³/h] at a pressure drop across valve of 1 bar, $\rho = 1000 \text{ kg/m}^3$

²⁾ The C_v value is the flow of water in [gal/min] at a pressure drop across valve of 1 psi, $\rho = 10 \text{ lbs/gal}$

Capacity

The capacity curves show the capacities of the individual valves (water quantity in [m³/h]) depending on the water pressure drop across the valve.

The capacity given apply at 85% valve opening and are obtained with the offset shown on page 4.

SI unit

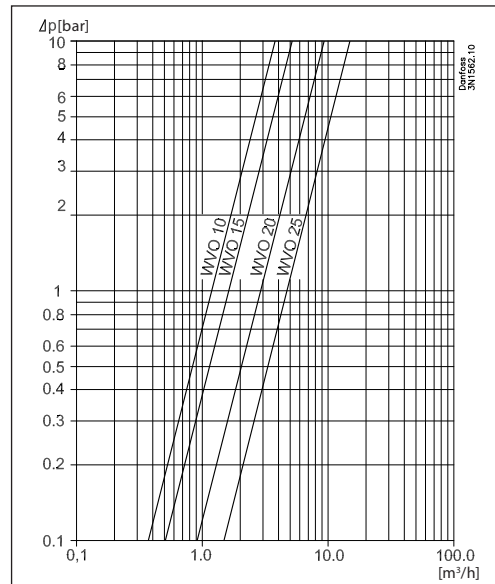

US unit

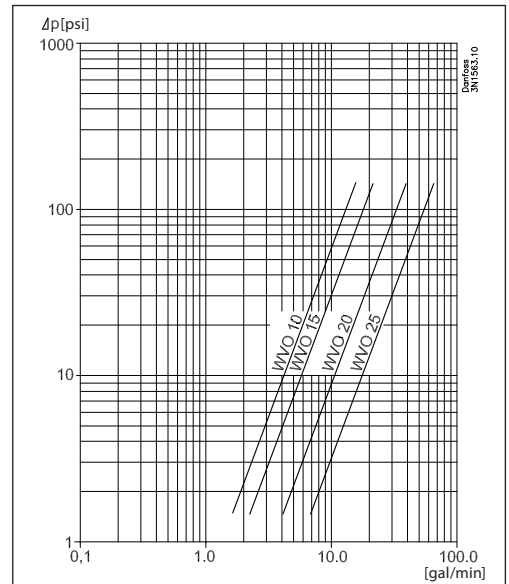

Ordering

Type	Connection type	Connection standard	Pressure range		Code no.
			[bar]	[psig]	
WVO 10	G 3/8	ISO 228-1	8 – 12	115 – 175	003N5203
WVO 10	G 3/8	ISO 228-1	14 – 18	200 – 260	003N5206
WVO 10	G 3/8	ISO 228-1	16 – 20	232 – 290	003N5207
WVO 10	G 3/8	ISO 228-1	16 – 22	232 – 320	003N6220 ¹⁾
WVO 15	G 1/2	ISO 228-1	Available on request		
WVO 20	G 3/4	ISO 228-1	Available on request		
WVO 25	G 1	ISO 228-1	Available on request		
WVO 10	NPT 3/8	ANSI/ASME B1.20.1	6 – 10	85 – 145	003N8052
WVO 10	NPT 3/8	ANSI/ASME B1.20.1	14 – 18	200 – 260	003N8056
WVO 15	NPT 1/2	ANSI/ASME B1.20.1	6 – 10	85 – 145	003N8062
WVO 15	NPT 1/2	ANSI/ASME B1.20.1	14 – 18	200 – 260	003N8066
WVO 20	NPT 3/4	ANSI/ASME B1.20.1	14 – 18	200 – 260	003N8076
WVO 25	NPT 1	ANSI/ASME B1.20.1	Available on request		

¹⁾ with 0.8 m capillary tube and valve opener.

Codes for valve with prefabricated factory setting, other sizes and pressure ranges

Accessories

Description	Code no.
1 m (39 in.) capillary tube 1/4 in. (6 mm) flare coupling nuts at each end	060-007166
Bracket	003N0388

Sizing

When sizing and selecting water valves it is most important to ensure that the valve at any time is able to give the necessary quantity of cooling water. To select a suitable size of valve it is necessary to know the precise amount of cooling required. On the other hand, to avoid the risk of unstable regulation (hunting) the valve should not be oversized. In general, the aim should be to select the smallest valve capable of giving the required flow .

To obtain a precise control it can be recommended to only use 85% of the capacity. Below 85% the ratio between flow and condensing difference pressure is linear. Above 85% the ratio is no longer linear . To reach a 100% capacity the WVO needs significant increase of condensing pressure. See table at the bottom of the page.

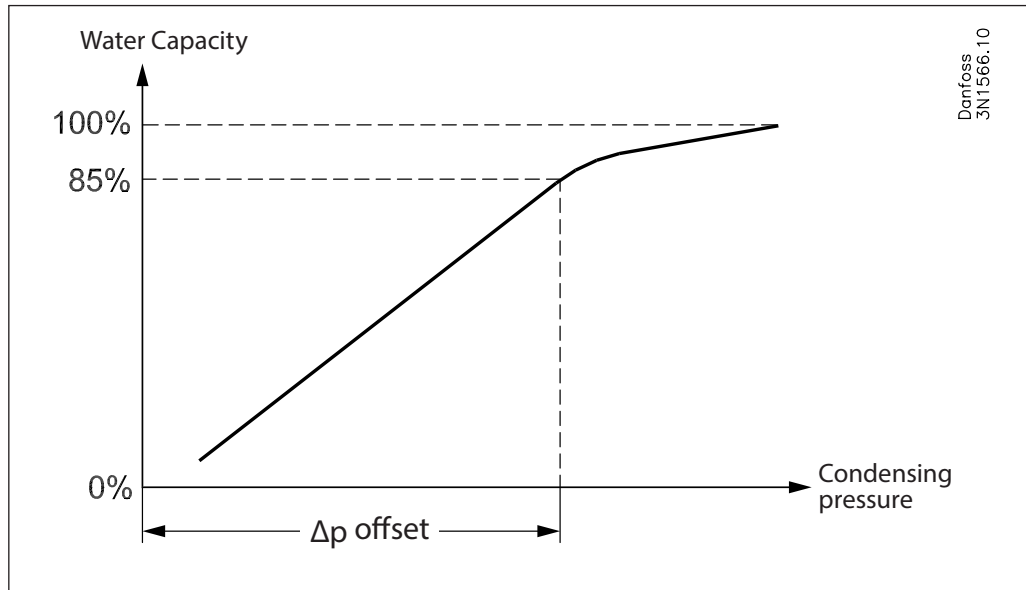

Type	ΔP offset	
	[bar]	[psi]
WVO 10	2.0	30
WVO 15	2.5	35
WVO 20	3.0	43
WVO 25	3.5	50

Valve size

The following data is used when selecting the size of WVO:

- Cooling capacity of condenser,
- Temperature rise in cooling media,
- Differential pressure across valve,
- Condensing temperature,
- Specific heat capacity of cooling media,
- Refrigerant.

Calculating size in SI Unit

Example 1:

- Condenser capacity Q_0 : 30 kW,
- Condensing temperature t_0 : 35 °C,
- Refrigerant: R404A,
- Cooling media: water,
- Specific heat capacity of water C_p : 4.19 kJ/(kg*K),
- Water inlet temperature t_1 : 15 °C,
- Water outlet temperature t_2 : 25 °C.
- Pressure drop across valve Δ_p : max. 1.0 bar

Necessary mass flow	$\dot{m} = \frac{Q_c}{C_p \cdot (t_2 - t_1)} \cdot 3600 = \frac{30}{4.19 \cdot (25 - 15)} \cdot 3600 = 2577 \text{ kg/h}$
Volume flow	$\dot{V} = \frac{\dot{m}}{\rho} = \frac{2577}{1000} \approx 2.6 \text{ m}^3/\text{h}$

Selecting size

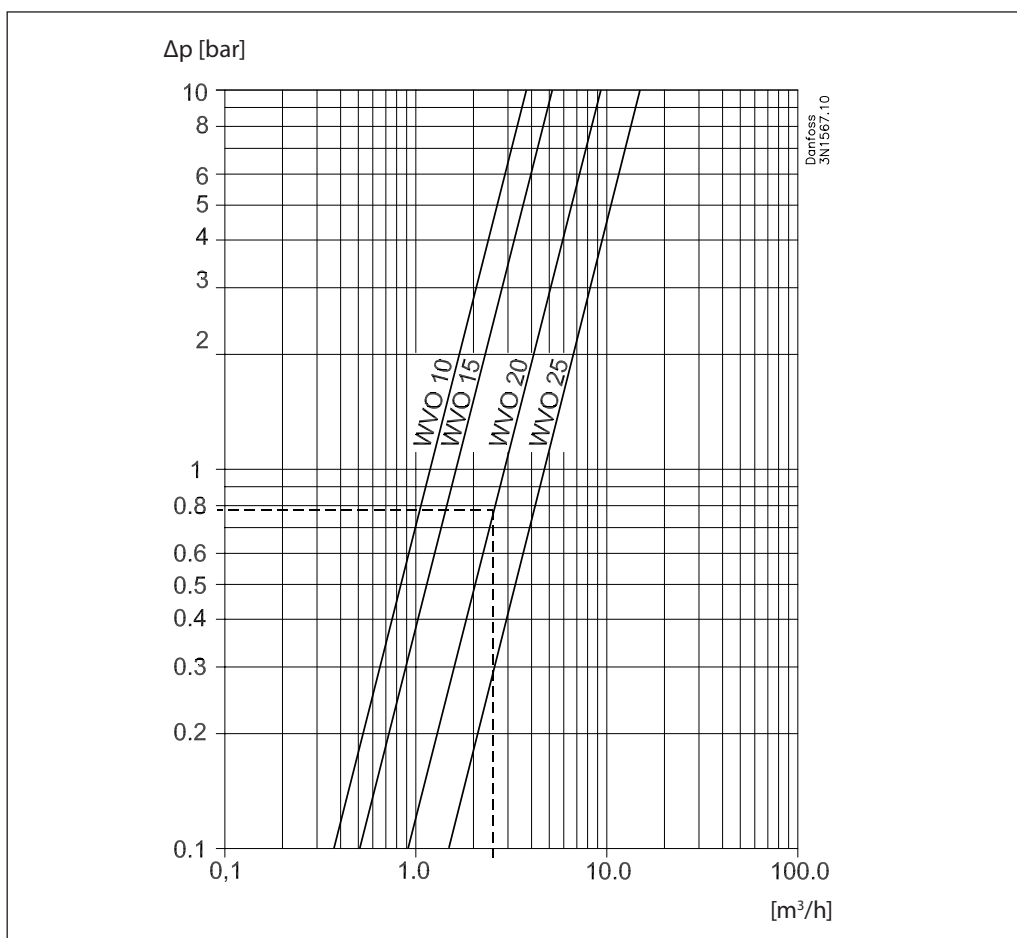

Selecting WVO 20 code number

The saturated pressure for R404A
 $T_c = 35 \text{ °C} \Rightarrow P_c = 7.9 \text{ barg}$

Choose a WVO 20 with 6 – 10 barg range.

Calculating size in SI Unit
(continue)

Example 2:

- Condenser capacity Q_c : 20 kW,
- Condensing temperature t_c : 35 °C,
- Refrigerant: R134a,
- Cooling media: Brine,
- Density of brine ρ : 1015 kg/m³,
- Specific heat capacity of brine C_p : 4.35 kJ (kg*K),
- Brine inlet temperature t_1 : 20 °C,
- Brine outlet temperature t_2 : 25 °C,
- Pressure drop across valve Δp : max. 2.0 bar.

Necessary mass flow	$\dot{m} = \frac{Q_c}{C_p \cdot (t_2 - t_1)} \cdot 3600 = \frac{20}{4.35 \cdot (25 - 20)} \cdot 3600 = 3310 \text{ kg/h}$
Volume flow	$\dot{V} = \frac{\dot{m}}{\rho} = \frac{3310}{1015} \approx 3.26 \text{ m}^3/\text{h}$
k_v value	$k_v \geq \frac{\dot{V}}{\sqrt{\frac{1000 \cdot \Delta p}{\rho}}} = \frac{3.26}{\sqrt{\frac{1000 \cdot 2.0}{1015}}} = 2,32 \text{ m}^3/\text{h}$

Selecting size of WVO 20

$k_v \geq 2.32 \text{ m}^3/\text{h} \Rightarrow$ **WVO 20**
WVO 20 has $k_v = 3.4 \text{ m}^3/\text{h}$ and the necessary capacity is below 85% of full capacity.

Code number

The saturated pressure for 134a
 $T_c = 35 \text{ °C } P_c = 7.9 \text{ barg}$

Choose a WVO 20 with 6 – 10 barg range.

Calculating size in US Unit

Example 1:

- Condenser capacity Q_c : 5 TR,
- Condensing temperature t_c : 95 °F,
- Refrigerant: R404A,
- Cooling media: water,
- Water inlet temperature t_1 : 60 °F,
- Water outlet temperature t_2 : 75 °F,
- Pressure drop across valve Δp : max. 15 psi.

Necessary water flow	$V = \frac{Q_c \cdot 15000}{500 \cdot (t_2 - t_1)} = \frac{5 \cdot 15000}{500 \cdot (75 - 60)} = 10 \text{ GPM}$
----------------------	--

Selecting size

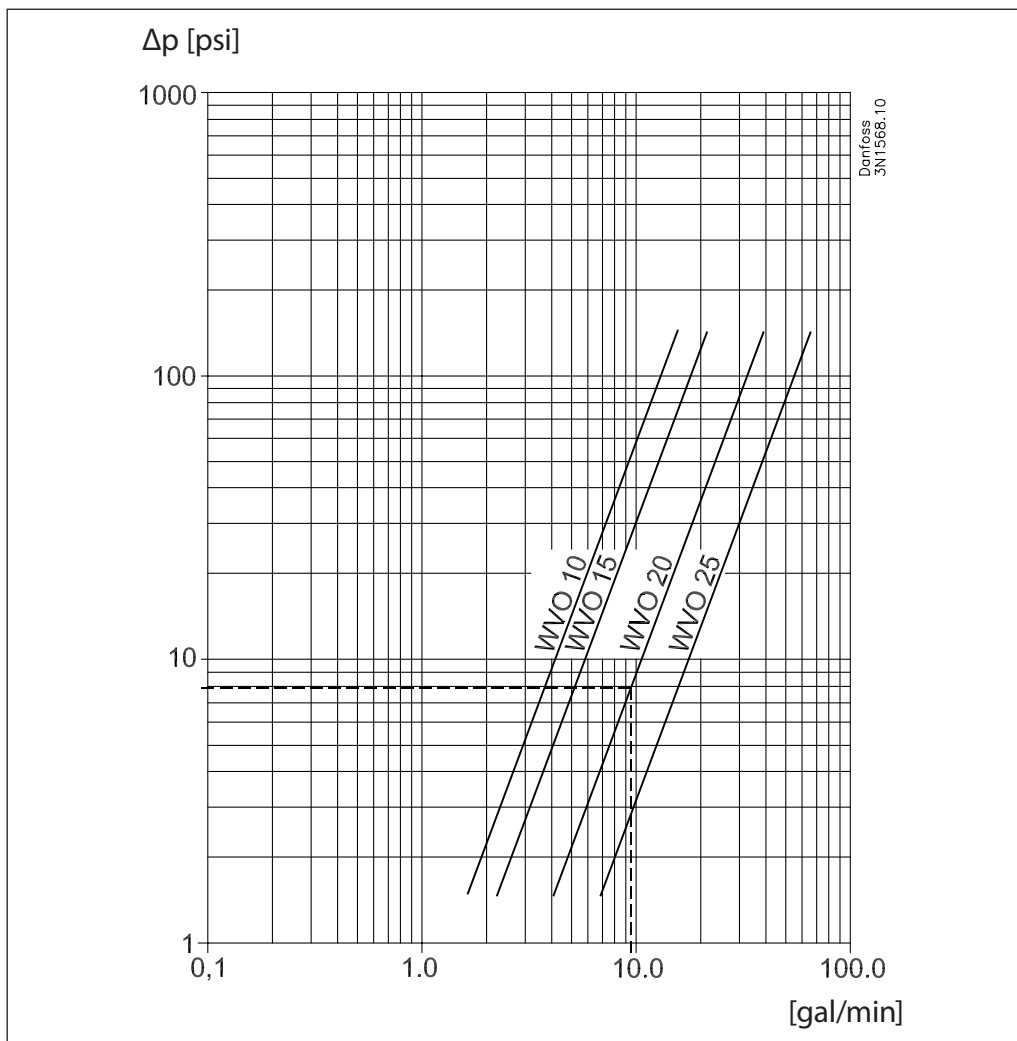

Selecting WVO 20 code number

The saturated pressure for R404A
 $T_c = 95 \text{ °F} \Rightarrow P_c = 115 \text{ psig}$

Choose a WVO 20 with 85 – 145 psig range.

Design / Function

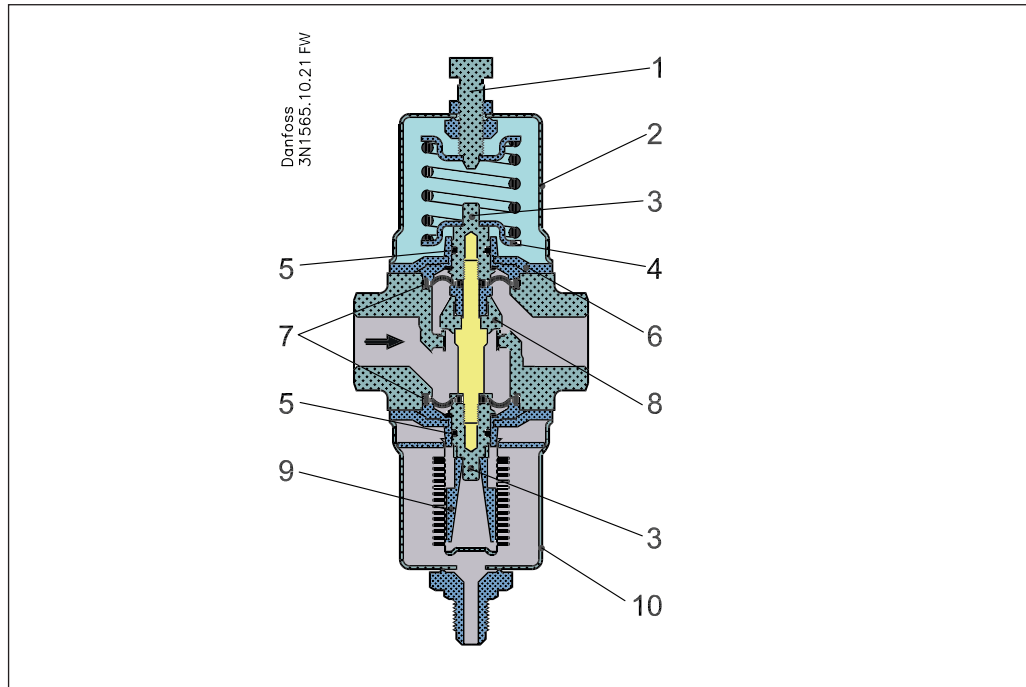

- 1. Screw for setting pressure
- 2. Spring housing
- 3. Spindle retainers
- 4. Spring retainers
- 5. O-ring
- 6. Guide bush
- 7. Diaphragm
- 8. Valve plate
- 9. Thrust pad
- 10. Bellows element

Condensing pressure impulses are transmitted via the bellows element to the valve cone so that the valve - even at very small pressure variations - is able to adapt the quantity of water required by the condenser.

If fluorinated refrigerants are to be used a capillary tube connection is required, 1 m capillary tube with ¼ in. / 6 mm flared union nuts at either end can be supplied.

The valves are pressure-relieved in such a way that a variation in the water pressure will not affect their setting.

To protect the refrigeration plant against high head pressures - in the event that the water supply to the condenser should fail - a safety switch type KP or RT should be fitted on the high pressure side.

The valve plate (8) is a brass plate with a vulcanized layer of special rubber to form an elastic seal against the valve seat. The valve is externally sealed by the diaphragms (7).

The top and bottom of the valve plate holder is extended by a guide that is fitted with O-rings (5) to ensure the internal operating parts move correctly. These O-rings, fitted in conjunction with the diaphragms, also provide extra protection against external leakage.

The valve seat is made of stainless steel and is swaged to the valve body.

The spring housing (2) is of aluminium and has a guide slot for the spring holder that is extended in the form of an indicating pointer. An associated indicator label is riveted to the housing and is graduated from 1 to 15.

Installation

Between the flare connection of the water valve and the pipe line / compressor Danfoss recommends to use capillary tube to avoid fatigue error due to the vibration from the compressor.

The installation of an MESH 40 filter ahead of the valve is recommended.

If a mounting bracket is used it must always be between valve body and setting section.

Dimensions and weights

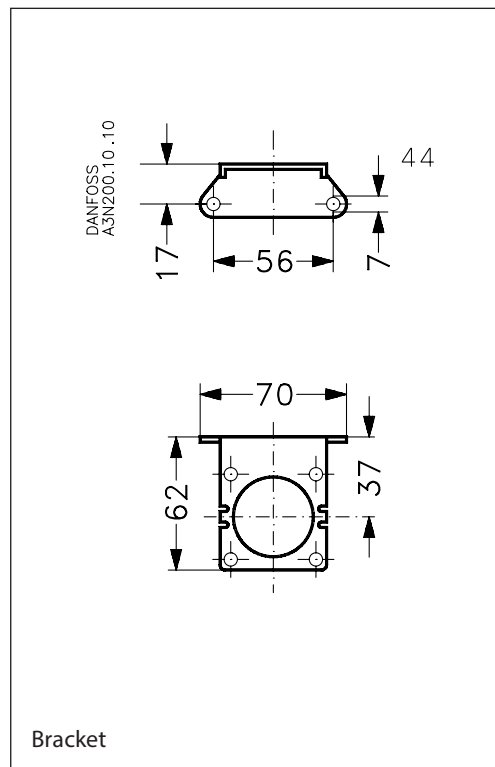
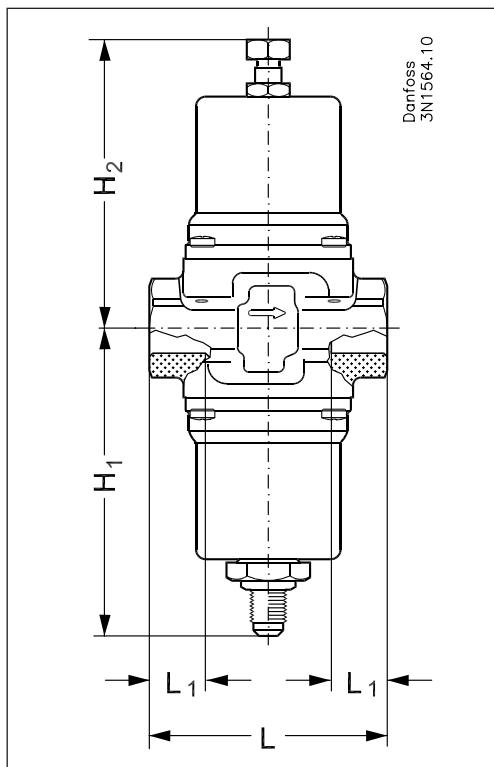

Type	H ₁		H ₂		L		L ₁		Net weight	
	[mm]	[in.]	[mm]	[in.]	[mm]	[in.]	[mm]	[in.]	[kg]	[lbs]
WVO 10	91	3.58	89	3.50	72	2.83	11	0.43	1.0	2.20
WVO 15	91	3.58	89	3.50	72	2.83	14	0.55	1.0	2.20
WVO 20	91	3.58	89	3.50	90	3.54	16	0.63	2.0	4.40
WVO 25	96	3.78	94	3.70	96	3.74	19	0.75	2.0	4.40

Danfoss can accept no responsibility for possible errors in catalogues, brochures and other printed material. Danfoss reserves the right to alter its products without notice. This also applies to products already on order provided that such alterations can be made without subsequential changes being necessary in specifications already agreed. All trademarks in this material are property of the respective companies. Danfoss and the Danfoss logotype are trademarks of Danfoss A/S. All rights reserved.