



Tecumseh

Compressor Voltage Code : XC

FH4524Z-XC

High Temp. Commercial (HP)

220 - 240V 1~ 50 Hz

R452A / R404A / R448A / R449A

FH4524Z-XC3A

Conditions	Frequency	Nominal Cooling Capacity		Sound Power ISO3745 / ISO 3743-1
		Watts	BTU/h	
EN12900_MHP / R452A	50 Hz	2979	10160	73 dBA
EN12900_MHP / R404A	50 Hz	3071	10471	73 dBA
EN12900_MHP / R448A	50 Hz	2834	9664	73 dBA
EN12900_MHP / R449A	50 Hz	2834	9664	73 dBA

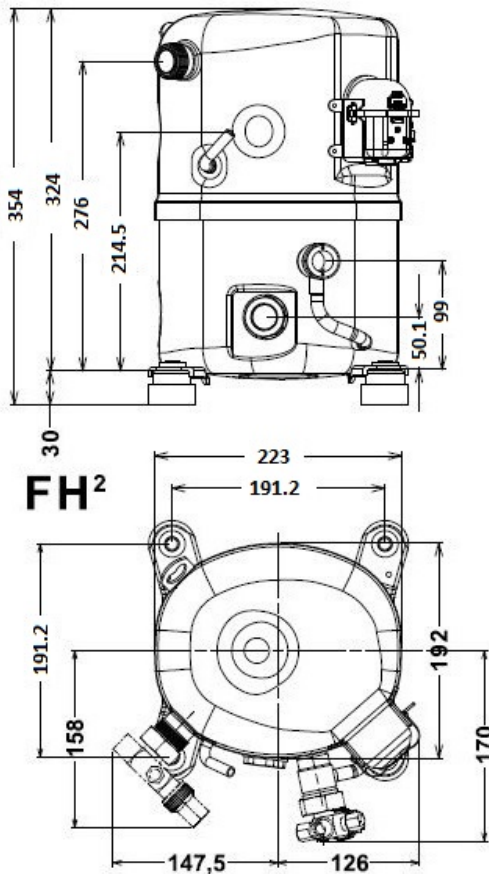

Displacement (cc)	43,3
Net Weight (Kg)	29.0
Oil Quantity (cc)	1140.0
Oil Type	Polyolester
Expansion Device	Capillary_Tube/Expansion_Valve
Cooling	Fan
Main Winding (Ohm)	1.31
Start Winding (Ohm)	3.8
Current	
RLA (A)	10.5
MCC (A)	15.9
LRA (A)	52
Electrical Equipment	CSR
Overload	Interne
Start Capacitor	88 µF / 330 V
Run Capacitor	35 µF / 400 V
Potential Relay	RVA4G**
Pick Up	180/195V
Drop Out	40/105V
Refrigerating connection for OD	
Suction Tube	15.9 (5/8")
Discharge Tube	12.7 (1/2")
Process Tube	6.35 (1/4")

* EN12900_MHP : T°Cond. 45.0°C / T°Evap. -10.0°C / T°Return gas temp.. 20.0°C
T°Subcooling. 0.0K

Certificates :



Note : Tecumseh reserves the right to change information contained in this document without notification.



Tecumseh

FH4524Z-XC	Tension XC : 220 - 240V 1~ 50 Hz
-------------------	---

Les performances sont données dans les **conditions EN12900_MHP** :
 Condition Dew
 The performance data are in **EN12900_MHP conditions** :
 Dew Condition

Gaz aspirés : 20.0 °C
 Sous refroidissement : 0.0 K
 Return gas : 20.0 °C
 Subcooling : 0.0 K

© 2021 Tecumseh Products Company
All rights reserved

50 Hz R452A

N°User-206

4 T condensation	5 T évaporation	(°C)	-25	-20	-15	-10	-5	0	5	10	15
30	1 P frigorifique	(Watt)	1810	2490	3288	4220	5306	6563	8009	9664	11544
	2 P absorbée	(W)	1003	1138	1253	1349	1425	1480	1513	1523	1510
	3 I absorbée	(A)	4.79	5.37	5.91	6.38	6.77	7.04	7.18	7.15	6.94
40	1 P frigorifique	(Watt)		1883	2582	3385	4312	5380	6607	8012	9612
	2 P absorbée	(W)		1171	1337	1483	1608	1712	1794	1853	1888
	3 I absorbée	(A)		5.58	6.29	6.96	7.55	8.05	8.43	8.66	8.73
50	1 P frigorifique	(Watt)			1908	2583	3350	4228	5236	6390	7710
	2 P absorbée	(W)			1357	1560	1742	1903	2041	2157	2248
	3 I absorbée	(A)			6.46	7.34	8.18	8.94	9.60	10.1	10.5
60	1 P frigorifique	(Watt)				1824	2432	3120	3908	4812	5852
	2 P absorbée	(W)				1566	1812	2037	2239	2418	2572
	3 I absorbée	(A)				7.36	8.48	9.54	10.5	11.4	12.1

50 Hz R404A

N°User-205

4 T condensation	5 T évaporation	(°C)	-25	-20	-15	-10	-5	0	5	10	15
30	1 P frigorifique	(Watt)	1950	2627	3423	4356	5443	6699	8143	9792	11661
	2 P absorbée	(W)	1075	1211	1327	1422	1493	1538	1556	1544	1500
	3 I absorbée	(A)	5.13	5.72	6.26	6.73	7.09	7.32	7.38	7.25	6.90
40	1 P frigorifique	(Watt)	1407	2009	2699	3492	4407	5460	6668	8048	9616
	2 P absorbée	(W)	1068	1250	1415	1560	1683	1782	1856	1902	1918
	3 I absorbée	(A)	5.23	5.96	6.66	7.32	7.90	8.38	8.72	8.89	8.87
50	1 P frigorifique	(Watt)		1419	2003	2658	3403	4253	5225	6338	7607
	2 P absorbée	(W)		1231	1446	1644	1822	1978	2110	2216	2295
	3 I absorbée	(A)		5.99	6.88	7.74	8.55	9.29	9.92	10.4	10.7
60	1 P frigorifique	(Watt)			1350	1868	2443	3091	3830	4676	5646
	2 P absorbée	(W)			1417	1670	1905	2120	2314	2483	2627
	3 I absorbée	(A)			6.77	7.85	8.91	9.93	10.9	11.7	12.4

1 = cooling capacity 2 = power input 3 = current 4 = condensing temperature 5 = evaporating temperature

Nota : Tecumseh se réserve le droit de modifier les informations contenues dans ce document sans préavis.

Note : Tecumseh reserves the right to change information contained in this document without notification.



Tecumseh

FH4524Z-XC	Tension XC : 220 - 240V 1~ 50 Hz
-------------------	---

Les performances sont données dans les **conditions EN12900_MHP** :
 Condition Dew
 The performance data are in **EN12900_MHP conditions** :
 Dew Condition

Gaz aspirés : 20.0 °C
 Sous refroidissement : 0.0 K
 Return gas : 20.0 °C
 Subcooling : 0.0 K

© 2021 Tecumseh Products Company
All rights reserved

50 Hz R448A (*)

N°User-208

4 T condensation	5 T évaporation	(°C)	-25	-20	-15	-10	-5	0	5	10	15
30	1 P frigorifique	(Watt)	1611	2250	3014	3922	4994	6251	7711	9395	11322
	2 P absorbée	(W)	946	1068	1177	1268	1340	1389	1412	1407	1371
	3 I absorbée	(A)	4.52	5.05	5.55	6.00	6.36	6.61	6.70	6.61	6.30
40	1 P frigorifique	(Watt)		1732	2402	3190	4115	5198	6457	7913	9586
	2 P absorbée	(W)		1107	1258	1395	1515	1614	1690	1740	1760
	3 I absorbée	(A)		5.27	5.92	6.55	7.11	7.59	7.94	8.13	8.14
50	1 P frigorifique	(Watt)			1817	2488	3270	4182	5244	6476	7897
	2 P absorbée	(W)			1289	1477	1650	1806	1940	2050	2133
	3 I absorbée	(A)			6.13	6.95	7.75	8.48	9.12	9.63	9.98
60	1 P frigorifique	(Watt)				1836	2478	3223	4092	5103	6277
	2 P absorbée	(W)				1502	1735	1952	2150	2326	2479
	3 I absorbée	(A)				7.06	8.12	9.14	10.1	10.9	11.7

50 Hz R449A (*)

N°User-207

4 T condensation	5 T évaporation	(°C)	-25	-20	-15	-10	-5	0	5	10	15
30	1 P frigorifique	(Watt)	1611	2250	3014	3922	4994	6251	7711	9395	11322
	2 P absorbée	(W)	946	1068	1177	1268	1340	1389	1412	1407	1371
	3 I absorbée	(A)	4.52	5.05	5.55	6.00	6.36	6.61	6.70	6.61	6.30
40	1 P frigorifique	(Watt)		1732	2402	3190	4115	5198	6457	7913	9586
	2 P absorbée	(W)		1107	1258	1395	1515	1614	1690	1740	1760
	3 I absorbée	(A)		5.27	5.92	6.55	7.11	7.59	7.94	8.13	8.14
50	1 P frigorifique	(Watt)			1817	2488	3270	4182	5244	6476	7897
	2 P absorbée	(W)			1289	1477	1650	1806	1940	2050	2133
	3 I absorbée	(A)			6.13	6.95	7.75	8.48	9.12	9.63	9.98
60	1 P frigorifique	(Watt)				1836	2478	3223	4092	5103	6277
	2 P absorbée	(W)				1502	1735	1952	2150	2326	2479
	3 I absorbée	(A)				7.06	8.12	9.14	10.1	10.9	11.7

1 = cooling capacity 2 = power input 3 = current 4 = condensing temperature 5 = evaporating temperature

(*) Veuillez vous référer strictement aux Recommandations d'Utilisation et Bulletins Marketing Tecumseh du fait de la température de reflux élevée pour les applications LBP.

(*) Due to very high discharge temperature especially on LBP conditions, please strictly refer to Tecumseh Guidelines & Marketing Bulletin when using this refrigerant.

Nota : Tecumseh se réserve le droit de modifier les informations contenues dans ce document sans préavis.

Note : Tecumseh reserves the right to change information contained in this document without notification.