



Condensing unit  
Voltage Code : XG

# FHT4525YHR-XG

High Temp. Commercial (HP)

380-420V 3~ 50Hz / 460V 3~ 60 Hz

R134a / R513A

FHT4525YHR-XG

Conditions	Frequency	Nominal Cooling Capacity		Sound Power ISO3745 / ISO 3743-1
		Watts	BTU/h	
EN13215 / R134a	50 Hz / 60 Hz	2917 / 3236	9947 / 11035	74 dBA
EN13215 / R513A	50 Hz / 60 Hz	3051 / 3362	10405 / 11463	74 dBA

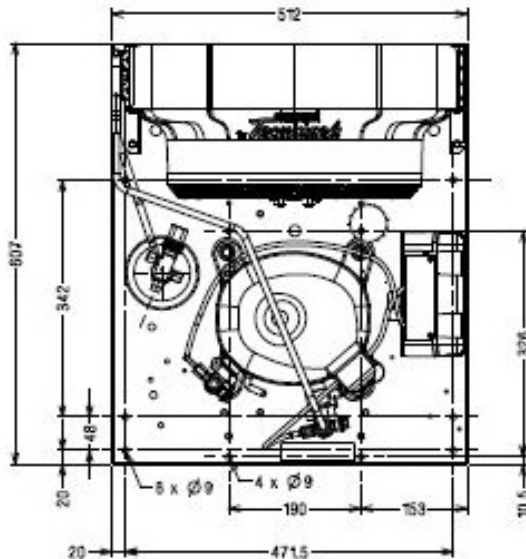
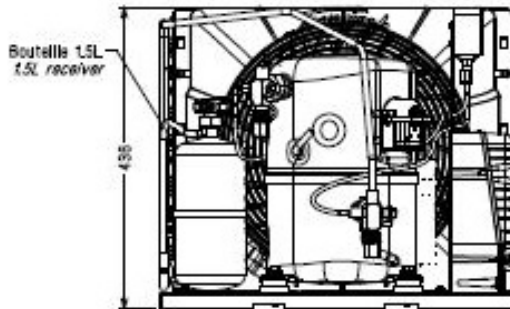

\* EN13215 : T°Ambient 32.0°C / T°Evap. -10.0°C / T°Return gas temp.. 20.0°C  
T°Subcooling. 3.0K

<b>Net Weight (Kg)</b>	50.0
<b>Expansion device</b>	Expansion_Valve
<b>Air Flow (m³/h)</b>	1650 / 1730
<b>Elec Comp Type</b>	TRI
<b>Current (Amp)</b>	
Load Rated Amp	3.8   4
Max Cont Current	6.3
Lock Rotor Amp	26
<b>Fan</b>	
Speed (rpm)	1335 / 1500
Power (W)	90.0
Diameter (mm)	350
Protection	Overload
IP Level	IP54
<b>Condenser</b>	M350/9100
<b>Liquid Receiver</b>	
Capacity (L)	1.5
Maximum Pressure (Bars)	32.0
<b>Suction Line</b>	
Suction Type	Vanne Orientable
For Tubing Out Diam	15.9 (5/8")
Suction Connection Type	Brased
<b>Liquid Line</b>	
Liquid Line Type	Vanne Orientable
For Tubing Out Diam	9.5 (3/8")
Liquid Connecton Type	Brased
<b>Connection Type</b>	VR
<b>Fan Guard</b>	maille < à 8mm

Note : Tecumseh reserves the right to change information contained in this document without notification.



**Tecumseh**

<b>FHT4525YHR-XG</b>	<b>Tension XG : 380-420V 3~ 50Hz / 460V 3~ 60 Hz</b>
----------------------	--

Les performances sont données dans les <b>conditions EN13215</b> :	Gaz aspirés :	20.0 °C
Condition Dew	Sous refroidissement :	3.0 K
The performance data are in <b>EN13215 conditions</b> :	Return gas :	20.0 °C
Dew Condition	Subcooling :	3.0 K

© 2020 Tecumseh Products Company  
All rights reserved

### 50 Hz R134a

N°User-335

5   T ambience	6   T évaporation	(°C)	-25	-20	-15	-10	-5	0	5	10	15
<b>25</b>	1   P frigorifique	(Watt)	1407	1952	2589	3318	4132	5021	5966	6942	7914
	2   P absorbée	(W)	903	1025	1154	1292	1445	1618	1818	2056	2341
	3   I absorbée	(A)	1.89	2.13	2.37	2.62	2.89	3.19	3.52	3.89	4.31
	4   Tc	(°C)	30.7	32.4	34.2	36.3	38.7	41.4	44.5	48.0	52.1
<b>32</b>	1   P frigorifique	(Watt)		1660	2247	2917	3668	4493	5380	6310	7258
	2   P absorbée	(W)		1043	1188	1344	1515	1705	1922	2174	2470
	3   I absorbée	(A)		2.10	2.39	2.68	2.99	3.32	3.67	4.07	4.50
	4   Tc	(°C)		38.9	40.7	42.7	44.9	47.4	50.1	53.3	56.8
<b>43</b>	1   P frigorifique	(Watt)			1742	2326	2982	3710	4507	5364	
	2   P absorbée	(W)			1212	1401	1605	1829	2077	2355	
	3   I absorbée	(A)			2.40	2.76	3.13	3.51	3.91	4.34	
	4   Tc	(°C)			50.9	52.8	54.8	56.8	59.0	61.5	

### 60 Hz R134a

N°User-335

5   T ambience	6   T évaporation	(°C)	-25	-20	-15	-10	-5	0	5	10	15
<b>25</b>	1   P frigorifique	(Watt)	1518	2148	2879	3714	4645	5663	6745	7863	8980
	2   P absorbée	(W)	1074	1234	1401	1579	1774	1993	2245	2541	2894
	3   I absorbée	(A)	1.96	2.22	2.48	2.75	3.04	3.35	3.69	4.07	4.51
	4   Tc	(°C)	33.8	35.4	37.2	39.1	41.4	44.0	47.0	50.5	54.4
<b>32</b>	1   P frigorifique	(Watt)		1798	2471	3236	4092	5032	6044	7106	8189
	2   P absorbée	(W)		1243	1434	1637	1857	2100	2374	2688	3055
	3   I absorbée	(A)		2.19	2.49	2.81	3.13	3.48	3.85	4.25	4.70
	4   Tc	(°C)		42.1	43.8	45.7	47.8	50.2	52.8	55.9	59.3
<b>43</b>	1   P frigorifique	(Watt)			1872	2536	3279	4103	5005		
	2   P absorbée	(W)			1449	1696	1961	2249	2563		
	3   I absorbée	(A)			2.51	2.89	3.27	3.68	4.09		
	4   Tc	(°C)			54.3	56.1	57.9	59.9	62.0		

1 = cooling capacity 2 = power input 3 = current 4 = condensing temperature 5 = ambient temperature 6 = evaporating temperature

Nota : Tecumseh se réserve le droit de modifier les informations contenues dans ce document sans préavis.

Note : Tecumseh reserves the right to change information contained in this document without notification.



**Tecumseh**

<b>FHT4525YHR-XG</b>	<b>Tension XG : 380-420V 3~ 50Hz / 460V 3~ 60 Hz</b>
----------------------	--

Les performances sont données dans les <b>conditions EN13215</b> :	Gaz aspirés :	20.0 °C
Condition Dew	Sous refroidissement :	3.0 K
The performance data are in <b>EN13215 conditions</b> :	Return gas :	20.0 °C
Dew Condition	Subcooling :	3.0 K

© 2020 Tecumseh Products Company  
All rights reserved

### 50 Hz R513A

N°User-336

5   T ambience	6   T évaporation	(°C)	-25	-20	-15	-10	-5	0	5	10	15
<b>25</b>	1   P frigorifique	(Watt)	1577	2143	2784	3498	4276	5103	5955	6801	7600
	2   P absorbée	(W)	993	1118	1247	1386	1541	1722	1939	2203	2529
	3   I absorbée	(A)	2.05	2.28	2.53	2.78	3.06	3.37	3.72	4.13	4.62
	4   Tc	(°C)	31.5	33.4	35.4	37.6	40.1	42.9	46.1	49.9	54.2
<b>32</b>	1   P frigorifique	(Watt)	1273	1798	2391	3051	3773	4546	5351	6165	6951
	2   P absorbée	(W)	983	1126	1274	1432	1606	1803	2034	2310	2645
	3   I absorbée	(A)	1.96	2.24	2.53	2.83	3.15	3.49	3.87	4.29	4.79
	4   Tc	(°C)	37.8	39.8	41.8	43.8	46.1	48.6	51.5	54.8	58.6
<b>43</b>	1   P frigorifique	(Watt)			1823	2394	3024	3707	4436	5194	
	2   P absorbée	(W)			1283	1478	1689	1920	2181	2481	
	3   I absorbée	(A)			2.53	2.90	3.28	3.67	4.09	4.55	
	4   Tc	(°C)			51.7	53.6	55.5	57.6	59.9	62.5	

### 60 Hz R513A

N°User-336

5   T ambience	6   T évaporation	(°C)	-25	-20	-15	-10	-5	0	5	10	15
<b>25</b>	1   P frigorifique	(Watt)	1685	2338	3076	3896	4787	5733	6708	7676	8589
	2   P absorbée	(W)	1176	1341	1510	1690	1890	2119	2390	2717	3118
	3   I absorbée	(A)	2.10	2.37	2.63	2.91	3.20	3.52	3.89	4.31	4.81
	4   Tc	(°C)	34.7	36.5	38.4	40.4	42.8	45.5	48.6	52.3	56.5
<b>32</b>	1   P frigorifique	(Watt)		1931	2609	3362	4184	5063	5980	6905	7800
	2   P absorbée	(W)		1337	1534	1741	1966	2219	2510	2854	3266
	3   I absorbée	(A)		2.32	2.63	2.96	3.29	3.65	4.04	4.48	4.98
	4   Tc	(°C)		43.0	44.9	46.8	49.0	51.4	54.2	57.4	61.1
<b>43</b>	1   P frigorifique	(Watt)			1950	2592	3299	4066	4885		
	2   P absorbée	(W)			1525	1785	2061	2359	2691		
	3   I absorbée	(A)			2.62	3.02	3.42	3.84	4.28		
	4   Tc	(°C)			55.1	56.9	58.7	60.7	62.9		

1 = cooling capacity 2 = power input 3 = current 4 = condensing temperature 5 = ambient temperature 6 = evaporating temperature

Nota : Tecumseh se réserve le droit de modifier les informations contenues dans ce document sans préavis.

Note : Tecumseh reserves the right to change information contained in this document without notification.