

Technical brochure

Filter

FIA and FIA-SS



FIA filters are a range of angle-way and straight-way filters which are carefully designed to give favourable flow conditions. The design makes the filter easy to install, and ensures quick filter inspection and cleaning.

FIA filters are used ahead of automatic controls, pumps, compressors etc., for initial plant start-up and where permanent filtration of the refrigerant is required. The filter reduces the risk of undesirable system breakdowns and reduces wear and tear on plant components.

FIA filters are equipped with a screen mesh of stainless steel, available in sizes 100, 150, 250 and 500 μ (microns*), (US 150, 100, 72, 38 mesh*).

* Mesh is the number of threads per inch.
 μ (microns) is the distance between two threads
 (1 μ = 1 / 1000 mm).

Features

- Applicable to all common refrigerants and all non-corrosive gases/liquids.
- Filter net of stainless steel mounted direct without extra gaskets means easy servicing.
- FIA filter housing compatible with housings belonging to other Danfoss products. A compatibility overview can be obtained from local Danfoss Sales Company
- Two types of filter inserts are available:
 - A plain insert of stainless steel
 - A pleated insert (DN 15-200) with extra large surface, which ensures long intervals between cleaning and low pressure drop.
- FIA 15-40 (½ - 1 ½ in.):
 A special insert (50 μ) can be used in combination with a standard version when cleaning a plant during commissioning.
- FIA 50-300 (2 - 12 in.):
 A large capacity filter bag (50 μ) can be inserted for cleaning plant during commissioning
- FIA 50-300 (2 - 12 in.) can be equipped with a magnetic insert for detention of iron particles and other magnetic particles.
- Each filter clearly marked with type, size and performance range
- Housing and bonnet of low temperature steel (FIA) or stainless steel (FIA-SS) in accordance with the requirements of the Pressure Equipment Directive and those of other international classification authorities
- Temperature range
 -60/+150°C (-76/+302°F)
- Pressure range:
 FIA: 40 bar g (580 psi g)
 FIA-SS: 52 bar g (754 psi g)
- Classification: DNV, LR, SAQ, CRN, BV etc.
 To obtain an updated product certification list please contact your local Danfoss Sales Company

Design
Connections

Available with the following connections:

- Butt-weld DIN (EN 10220)
- Butt-weld ANSI (B 36.10 Schedule 80), DN 15 - 40 (1/2 - 1 1/2 in.)
- Butt-weld ANSI (B 36.10 Schedule 40), DN 50 - 300 (2 - 12 in.)
- Socket Weld (ANSI B 16.11), DN 15 - DN 50 (1/2 - 2 in.)
- FPT Female Pipe Thread, NPT (ANSI/ASME B 1.20.1), DN 15 - 32 (1/2 - 1 1/4 in.)

Filter Insert

A filter grid and filter net of stainless steel ensure long element life. The filter net offers a very high degree of cleanability.

Housing

The filter housing is made of special, cold resistant steel (FIA) or stainless steel (FIA-SS) approved for low temperature application.

Pressure Equipment Directive (PED)

FIA filters are approved in accordance with the European standard specified in the Pressure Equipment Directive and are CE marked. For further details / restrictions - see Installation Instruction



Nominal bore	DN ≤ 25 (1 in.)	DN 32-80 mm (1 1/4 - 3 in.)	DN 100-250 mm (4-10 in.)	DN 300 (12 in.)
Classified for	Fluid group I			
Category	Article 3, paragraph 3	II	III	IV

Installation/Maintenance

The filter is designed to resist high internal pressures. However, the piping system in general should be designed to avoid liquid traps and reduce the risk of hydraulic pressure caused by thermal expansion.

Danfoss recommends replacement/cleaning of the filter when the differential pressure loss >0.5 bar (7.3 psi) in the liquid line and >0.05 bar (0.7 psi) in the suction line. The max. permissible differential pressure is 1 bar (15 psi).

Install the filter with the cover downward position.

For further information refer to installation instruction for FIA.

Identification:

DN 15 - 25
(1/2 - 1 in.)

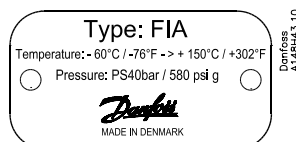

DN 32 - 300
(1 1/4 - 12 in.)

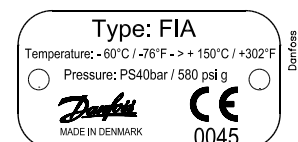
Technical data

- **Refrigerants**
Applicable to all common refrigerants including flammable refrigerants and all non-corrosive gases/liquids. For further information please see installation instruction for FIA.
- **Temperature range**
-60°C/+150°C (-76°F/+302°F).

- **Pressure range**
Max. working pressure:
FIA: 40 bar g (580 psi g).
FIA-SS: 52 bar g (754 psi g).

Filter, types FIA and FIA-SS

Selection of filter size

The mesh aperture size of the filter must satisfy the requirements stated by the suppliers of the equipment to be protected.

The following recommendations of aperture size apply in general to refrigeration installations:

All lines

First start up: **50μ**

(Use filter element with removable insert for FIA DN15-40 or separate filter bag for FIA DN 50-200. 50μ insert should normally be removed after the first 24 hours of operation)

Liquid Lines

Ahead of pumps: **500μ**

[38 mesh]

After pumps: **150μ**

[100 mesh] / 250μ [72 mesh]

In front of AKVA valves **100μ**

[150 mesh]

Protection of automatic regulation equipment

Generally **150μ**

[100 mesh] / 250μ [72 mesh]

Sensitive equipment, e.g.

suction regulators with low temperature **250μ**

[72 mesh]

Suction Lines

Ahead of screw compressor **250μ**

[72 mesh]

Ahead of piston compressor **150μ**

[100 mesh]

Definition

Mesh is the number of threads per inch. μ (microns) is the distance between two threads (1μ = 1 /1000 mm).

Flow coefficient (DIN/ANSI)

Size FIA	μ	mesh	wire mm	wire in.	free space %	screen area			
						Plain elements		Pleated elements	
						cm ²	in ²	cm ²	in ²
15 - 20 (1/2" - 3/4")	100		0.068	0.003	35	25	3.9	45	7.0
	150	100	0.10	0.004	36	25	3.9	45	7.0
	250	72	0.10	0.004	51	25	3.9	45	7.0
	500	38	0.16	0.006	57.6	25	3.9	45	7.0
25 - 40 (1" - 1 1/2")	100		0.068	0.003	35	71	11	160	25.0
	150	100	0.10	0.004	36	71	11	160	25.0
	250	72	0.10	0.004	51	71	11	160	25.0
	500	38	0.16	0.006	57.6	71	11	160	25.0
50 (2")	100		0.068	0.003	35	71	11	200	31.2
	150	100	0.10	0.004	36	87	13.5	200	31.2
	250	72	0.10	0.004	51	87	13.5	200	31.2
	500	38	0.16	0.006	57.6	87	13.5	200	31.2
65 (2 1/2")	150	100	0.10	0.004	36	127	19.7	305	47.6
	250	72	0.10	0.004	51	127	19.7	305	47.6
	500	38	0.16	0.006	57.6	127	19.7	305	47.6
	150	100	0.10	0.004	36	205	31.8	450	70.2
80 (3")	250	72	0.10	0.004	51	205	31.8	450	70.2
	500	38	0.16	0.006	57.6	205	31.8	450	70.2
	150	100	0.10	0.004	36	370	57.4	790	123.2
	250	72	0.10	0.004	51	370	57.4	790	123.2
100 (4")	500	38	0.16	0.006	57.6	370	57.4	790	123.2
	150	100	0.10	0.004	36	510	79.1	1105	172.4
	250	72	0.10	0.004	51	510	79.1	1105	172.4
	500	38	0.16	0.006	57.6	510	79.1	1105	172.4
125 (5")	150	100	0.10	0.004	36	726	112.5	1600	249.6
	250	72	0.10	0.004	51	726	112.5	1600	249.6
	500	38	0.16	0.006	57.6	726	112.5	1600	249.6
	150	100	0.10	0.004	36	1315	203.8		
150 (6")	250	72	0.10	0.004	51	1315	203.8		
	500	38	0.16	0.006	57.6	1315	203.8		
	150	100	0.10	0.004	36	1800	70.9		
	250	72	0.10	0.004	51	1800	70.9		
200 (8")	500	38	0.16	0.006	57.6	1800	70.9		
	150	100	0.10	0.004	36	2590	102.0		
	250	72	0.10	0.004	51	2590	102.0		
	500	38	0.16	0.006	57.6	2590	102.0		

Selection of filter size
(Continued)
K_v values

DN	FIA angle - plain filter net				FIA angle - pleated filter net		
	μ100	μ150	μ250	μ500	μ150	μ250	μ500
15	3.3	3.4	3.5	3.7	4.2		
20	6.9	7.1	7.3	7.7	8.8		
25	13.8	14.0	14.5	15.2	17.2	17.9	
32	23.0	23.8	24.7	25.5	29.2	30.5	
40	25.1	25.5	26.4	28.1	31.4	32.6	
50	45.1	45.9	47.6	50.2	56.7	58.8	62.0
65		56.1	57.8	60.4	69.3	71.4	74.6
80		104.6	108.0	113.1	129.2	133.4	139.7
100		162.4	167.5	176.0	200.6	206.9	217.4
125		275.4	283.9	298.4	340.2	350.7	368.6
150		362.1	373.2	391.9	447.3		
200		572.9	590.8	620.5			
250		784.5	808.9	849.7			
300		1062.3	1095.4	1150.8			

DN	FIA straight - plain filter net				FIA straight-pleated filter net		
	μ100	μ150	μ250	μ500	μ150	μ250	μ500
15	2.5	2.6	2.7	2.8	3.3		
20	5.3	5.4	5.6	5.9	6.9		
25	10.5	10.7	11.1	11.6	13.8	14.5	
32	17.6	18.2	18.9	19.5	23.9	24.7	
40	19.2	19.5	20.2	21.5	25.5	26.4	
50	34.5	35.1	36.4	38.4	45.9	47.6	50.2
65		42.9	44.2	46.2	56.1	57.8	60.4
80		80.0	82.6	86.5	104.6	108.0	113.1
100		124.2	128.1	134.6	162.4	167.5	176.0
125		210.6	217.1	228.2	275.4	283.9	298.4
150		276.9	285.4	299.7	362.1		
200		438.1	451.8	474.5			

Filter, types FIA and FIA-SS

Material specification

FIA, FIA-SS 15 - 40 (1/2 in. - 1 1/2 in.)

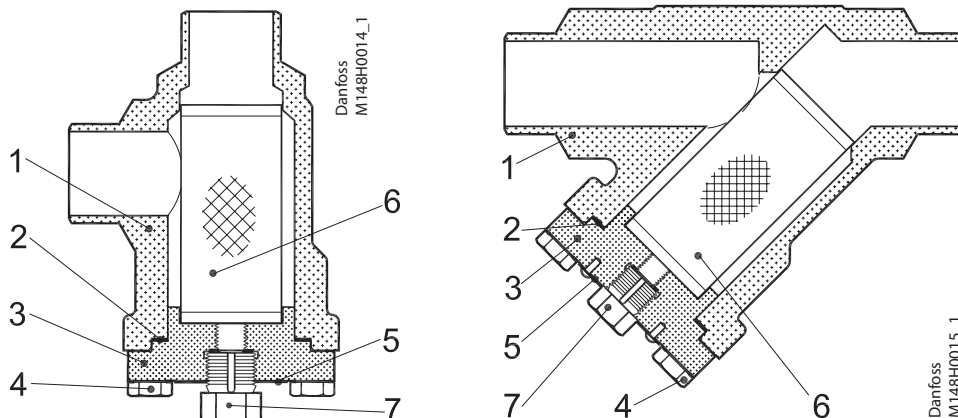

FIA, FIA-SS 15-40 (1/2 in. - 1 1/2 in.)

No.	Part	Material	DIN	ISO	ASTM
1	Housing	Steel	G20Mn5QT, 10213-3 ----- P285QH+QT, 10222-4		LCC, A352 ----- LF2, A350
		Stainless steel (FIA-SS only)	X5CrNi18-10 EN 10088		AISI 304
2	Gasket	Fibre, Non-asbestos			
3	Cover	Steel	P285QH EN 10028-3		
		Stainless steel (FIA-SS only)	X5CrNi18-10 EN 10088		AISI 304
4	Bolts	Stainless steel	A2-70	A2-70	Type 308
5	Marking label	Aluminium			
6	Filter element	Stainless steel			
7	Pressure relief (screw)	Stainless steel			

Filter, types FIA and FIA-SS

Material specification

FIA 50 - 200 (2 in. - 8 in.)

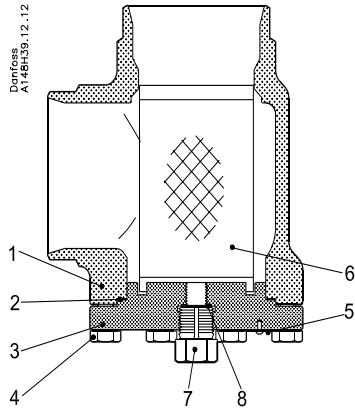

FIA 250 - 300 (10 in. - 12 in.)

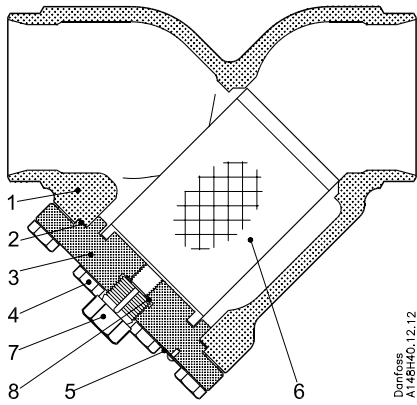
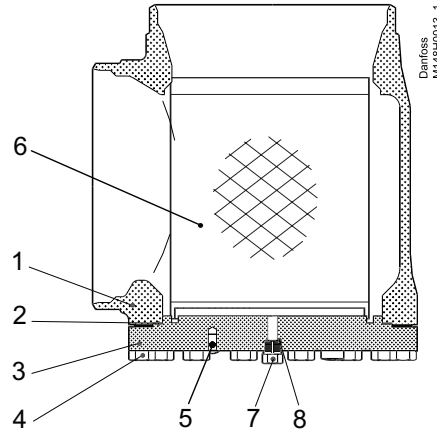

FIA 50-300 (2 in. - 12 in.)

No.	Part	Material	DIN	ISO	ASTM
1	Housing	Steel	G20Mn5QT, 10213-3		LCC, A352
2	Gasket	Fibre, Non-asbestos			
3	Cover	Steel	P285QH EN 10028-3		
4	Bolts	Stainless steel	A2-70	A2-70	Type 308
5	Marking label	Aluminium			
6	Filter element	Stainless steel			
7	Pressure relief (screw)	Stainless steel			
8*	Packing washer	Aluminium			

* pos 8 used in FIA 50-300

Filter, types FIA and FIA-SS

Connections

DIN

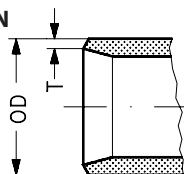

Size mm	Size in.	OD mm	T mm	OD in.	T in.
---------	----------	-------	------	--------	-------

Butt-weld DIN (EN 10220)

15	1/2	21.3	2.3	0.839	0.091
20	3/4	26.9	2.3	1.059	0.091
25	1	33.7	2.6	1.327	0.103
32	1 1/4	42.4	2.6	1.669	0.102
40	1 1/2	48.3	2.6	1.902	0.103
50	2	60.3	2.9	2.37	0.11
65	2 1/2	76.1	2.9	3	0.11
80	3	88.9	3.2	3.50	0.13
100	4	114.3	3.6	4.50	0.14
125	5	139.7	4.0	5.50	0.16
150	6	168.3	4.5	6.63	0.18
200	8	219.1	6.3	8.63	0.25
250	10	273	6.3	10.75	0.25
300	12	323.9	7.1	12.75	0.28

ANSI

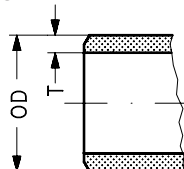

Size mm	Size in.	OD mm	T mm	OD in.	T in.
---------	----------	-------	------	--------	-------

Butt-weld ANSI (B 36.10 Schedule 80)

15	1/2	21.3	3.7	0.839	0.146
20	3/4	26.9	4.0	1.059	0.158
25	1	33.7	4.6	1.327	0.181
32	1 1/4	42.4	4.9	1.669	0.193
40	1 1/2	48.3	5.1	1.902	0.201

Butt-weld ANSI (B 36.10 Schedule 40)

50	2	60.3	3.9	2.37	0.15
65	2 1/2	73.0	5.2	2.87	0.20
80	3	88.9	5.5	3.50	0.22
100	4	114.3	6.0	4.50	0.24
125	5	141.3	6.6	5.56	0.26
150	6	168.3	7.1	6.63	0.28
200	8	219.1	8.2	8.63	0.32
250	10	273	6.3	10.75	0.25
300	12	323.9	7.1	12.75	0.28

SOC

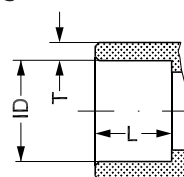

Size mm	Size in.	ID mm	T mm	ID in.	T in.	L mm	L in.
---------	----------	-------	------	--------	-------	------	-------

Socket welding ANSI (B 16.11)

15	1/2	21.8	6.0	0.858	0.235	10	0.39
20	3/4	27.2	4.6	1.071	0.181	13	0.51
25	1	33.9	7.2	1.335	0.284	13	0.51
32	1 1/4	42.7	6.1	1.743	0.240	13	0.51
40	1 1/2	48.8	6.6	1.921	0.260	13	0.51
50	2	61.2	6.2	2.41	0.24	16	0.63

FPT

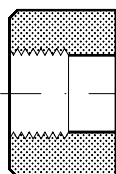

Size mm	Size in.	Inside pipe thread
---------	----------	--------------------

FPT inside pipe thread, NPT (ANSI/ASME B 1.20.1)

15	1/2	(1/2 × 14 NPT)
20	3/4	(3/4 × 14 NPT)
25	1	(1 × 11.5 NPT)
32	1 1/4	(1 1/4 × 11.5 NPT)

Dimensions and weights

FIA 15 - 65

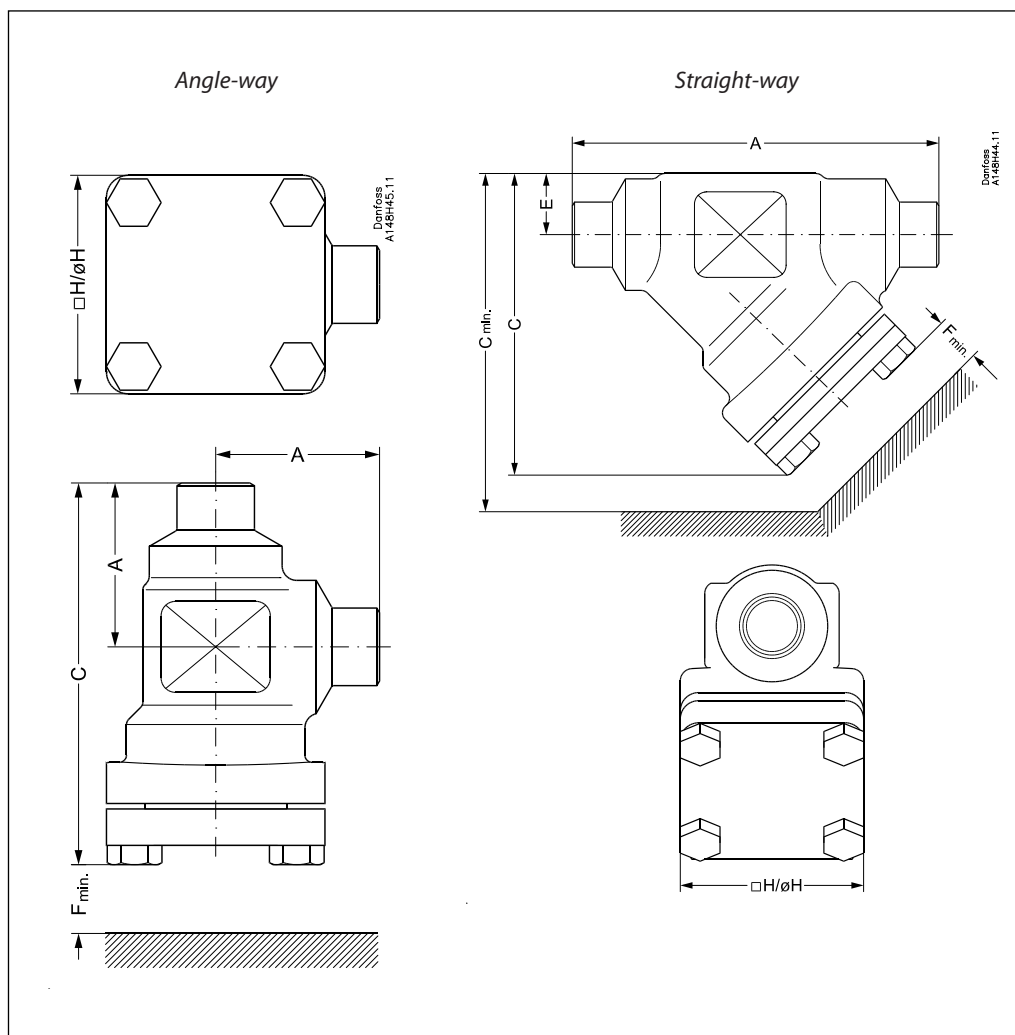

Angle-way

Filter size		A	C	H	F _{min.}	Weight
FIA 15-20	mm	45	105	60	68	1.1 kg
(1/2" - 3/4")	in.	1.77	4.13	2.36	2.68	2.4 lbs
FIA 25-40	mm	55	132	70	95	1.7 kg
(1" - 1 1/2")	in.	2.17	5.20	2.76	3.74	3.7 lbs
FIA 50	mm	60	132	77	92	2.8 kg
(2")	in.	2.36	5.20	3.03	3.62	6.2 lbs
FIA 65	mm	70	152	90	107	3.8 kg
(2 1/2")	in.	2.76	5.98	3.54	4.21	8.4 lbs

Straight-way

Valve size		A	C	C _{min.}	H	E	F _{min.}	Weight
FIA 15-20	mm	120	99	133	60	20	68	1.4 kg
(1/2" - 3/4")	in.	4.72	3.90	5.24	2.36	0.79	2.68	3.1 lbs
FIA 25-40	mm	155	129	177	70	26	95	2.4 kg
(1" - 1 1/2")	in.	6.10	5.08	6.97	2.76	1.02	3.74	5.3 lbs
FIA 50	mm	148	138	184	77	32	92	3.5 kg
(2")	in.	5.83	5.43	7.24	3.03	1.26	3.62	7.7 lbs
FIA 65	mm	176	165	219	90	40	107	5.3 kg
(2 1/2")	in.	6.93	6.50	8.62	3.54	1.57	4.21	11.7 lbs

Dimensions and weights

FIA 80 - 300

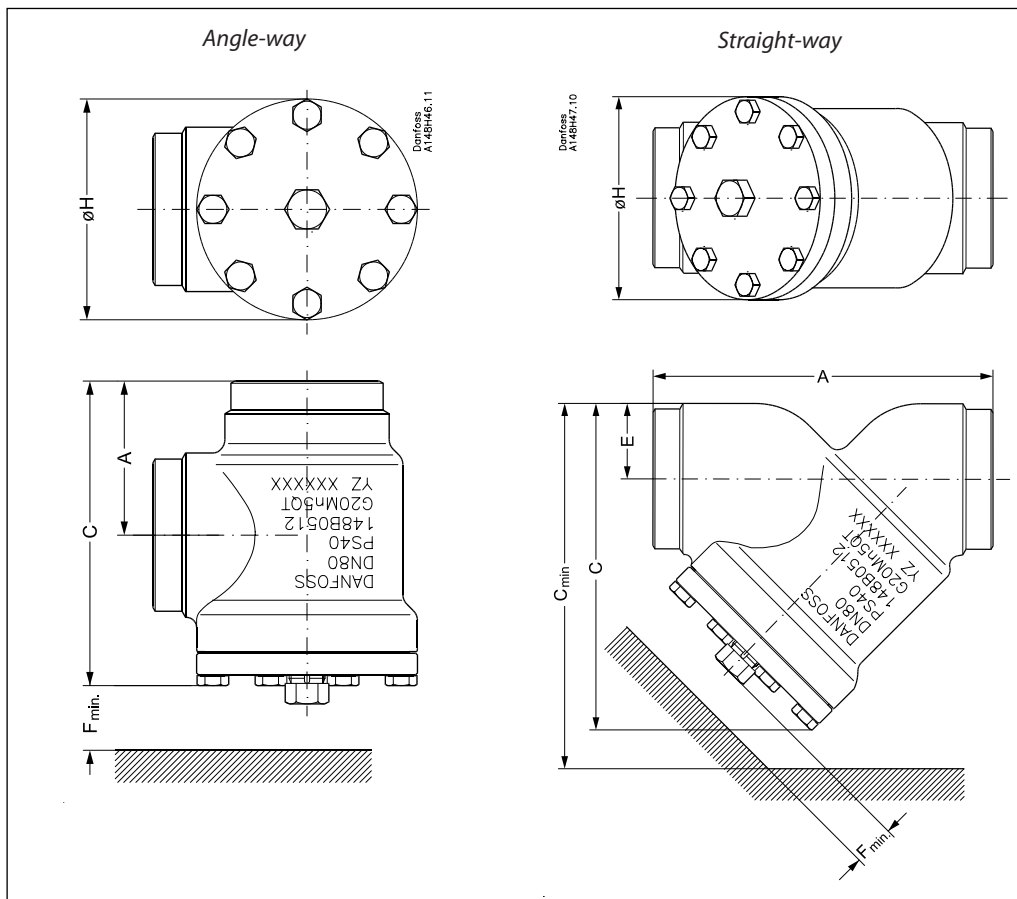

Angle-way

Filter size		A	C	H	F_{min}	Weight
FIA 80	mm	90	189	129	133	7.3 kg
(3")	in.	3.54	7.44	5.08	5.24	16.1 lbs
FIA 100	mm	106	223	156	163	11.9 kg
(4")	in.	4.17	8.78	6.14	6.42	26.2 lbs
FIA 125	mm	128	268	192	190	21.2 kg
(5")	in.	5.04	10.6	7.56	7.48	46.7 lbs
FIA 150	mm	145	303	219	223	30.5 kg
(6")	in.	5.71	11.93	8.62	8.78	67.2 lbs
FIA 200	mm	180	372	276	280	68 kg
(8")	in.	7.09	14.65	10.87	11.02	150 lbs
FIA 250	mm	210	397	334	285	89 kg
(10")	in.	8.27	15.63	13.14	11.22	196.3 lbs
FIA 300	mm	240	458	384	340	125 kg
(12")	in.	9.45	18.03	15.12	13.39	275.5 lbs

Straight-way

Filter size		A	C	C_{min}	H	E	F_{min}	Weight
FIA 80	mm	216	204	271	129	48	133	8.6 kg
(3")	in.	8.50	8.03	10.67	5.08	1.89	5.24	19 lbs
FIA 100	mm	264	256	337	156	60	163	14.9 kg
(4")	in.	10.39	10.08	13.27	6.14	2.36	6.42	32.8 lbs
FIA 125	mm	322	313	408	192	74	190	26.9 kg
(5")	in.	12.68	12.32	16.06	7.56	2.91	7.48	59.3 lbs
FIA 150	mm	370	370	482	219	91	223	51 kg
(6")	in.	14.57	14.57	18.98	8.62	3.58	8.78	112 lbs
FIA 200	mm	464	465	605	276	117	280	95 kg
(8")	in.	18.27	18.31	23.82	10.87	4.61	11.02	209 lbs

Filter, types FIA and FIA-SS
Ordering

The table below is used to identify the filter required.
Please note that you have to order **FIA filter housing, a filter element and accessories.**

Example:
FIA 50 D ANG + FIA-X 50 150µ Filter Element + Filter Bag = **148H3056 + 148H3130 + 148H3150**

Size		Type	Without Filter Element	Code number						
mm	in.			Filter Element 100µ 150 mesh	Filter Element 150µ 100 mesh	Filter Element 250µ 72 mesh	Filter Element 500µ 38 mesh	Pleated filter element 150µ 100 mesh	Pleated filter element 250µ 72 mesh	Pleated filter element 500µ 38 mesh
15	½	FIA 15 D ANG	148H3051	148H3122	148H3124	148H3126	148H3128	148H3303	148H3363	-
15	½	FIA-SS 15 D ANG 52BAR	148H3221							
15	½	FIA 15 A ANG	148H3063							
15	½	FIA 15 SOC ANG	148H3075							
15	½	FIA 15 FPT ANG	148H3081							
15	½	FIA 15 D STR	148H3085							
15	½	FIA-SS 15 D STR 52BAR	148H3285							
15	½	FIA 15 A STR	148H3097							
15	½	FIA 15 SOC STR	148H3109							
15	½	FIA 15 FPT STR	148H3115							
20	¾	FIA 20 D ANG	148H3052	148H3122	148H3124	148H3126	148H3128	148H3303	148H3363	-
20	¾	FIA-SS 20 D ANG 52BAR	148H3222							
20	¾	FIA 20 A ANG	148H3064							
20	¾	FIA 20 FPT ANG	148H3082							
20	¾	FIA 20 SOC ANG	148H3076							
20	¾	FIA 20 D STR	148H3086							
20	¾	FIA-SS 20 D STR 52BAR	148H3286							
20	¾	FIA 20 A STR	148H3098							
20	¾	FIA 20 FPT STR	148H3116							
20	¾	FIA 20 SOC STR	148H3110							
25	1	FIA 25 D ANG	148H3053	148H3123	148H3125	148H3127	148H3129	148H3304	148H3269	-
25	1	FIA-SS 25 D ANG 52BAR	148H3223							
25	1	FIA 25 A ANG	148H3065							
25	1	FIA 25 FPT ANG	148H3083							
25	1	FIA 25 SOC ANG	148H3077							
25	1	FIA 25 D STR	148H3087							
25	1	FIA-SS 25 D STR 52BAR	148H3287							
25	1	FIA 25 A STR	148H3099							
25	1	FIA 25 FPT STR	148H3117							
25	1	FIA 25 SOC STR	148H3111							
32	1¼	FIA 32 D ANG	148H3054	148H3123	148H3125	148H3127	148H3129	148H3304	148H3269	-
32	1¼	FIA-SS 32 D ANG 52BAR	148H3224							
32	1¼	FIA 32 A ANG	148H3066							
32	1¼	FIA 32 FPT ANG	148H3084							
32	1¼	FIA 32 SOC ANG	148H3078							
32	1¼	FIA 32 D STR	148H3088							
32	1¼	FIA-SS 32 D STR 52BAR	148H3288							
32	1¼	FIA 32 A STR	148H3100							
32	1¼	FIA 32 FPT STR	148H3118							
32	1¼	FIA 32 SOC STR	148H3112							
40	1½	FIA 40 D ANG	148H3055	148H3123	148H3125	148H3127	148H3129	148H3304	148H3269	-
40	1½	FIA-SS 40 D ANG 52BAR	148H3225							
40	1½	FIA 40 A ANG	148H3067							
40	1½	FIA 40 SOC ANG	148H3079							
40	1½	FIA 40 D STR	148H3089							
40	1½	FIA-SS 40 D STR 52BAR	148H3289							
40	1½	FIA 40 A STR	148H3101							
40	1½	FIA 40 SOC STR	148H3113							
50	2	FIA 50 D ANG	148H3056	148H3157	148H3130	148H3138	148H3144	148H3179	148H3184	148H3189
50	2	FIA-SS 50 D ANG 52BAR	148H3283							
50	2	FIA 50 A ANG	148H3068							
50	2	FIA 50 SOC ANG	148H3080							
50	2	FIA 50 D STR	148H3090							
50	2	FIA-SS 50 D STR 52BAR	148H3290							
50	2	FIA 50 A STR	148H3102							
50	2	FIA 50 SOC STR	148H3114							

D = Butt-weld DIN ANG = Angle-way
A = Butt-weld ANSI STR = Straight-way
SOC = Socket welding
FPT = Inside pipe thread

Filter, types FIA and FIA-SS

Ordering

Size		Type	Code number						
mm	in.		Without Filter Element	Filter Element 150 μ 100 mesh	Filter Element 250 μ 72 mesh	Filter Element 500 μ 38 mesh	Pleated filter element 150 μ 100 mesh	Pleated filter element 250 μ 72 mesh	Pleated filter element 500 μ 38 mesh
65	2½	FIA 65 D ANG	148H3057	148H3131	148H3139	148H3145	148H3180	148H3185	148H3190
65	2½	FIA-SS 65 D ANG 52BAR	148H3284						
65	2½	FIA 65 A ANG	148H3069						
65	2½	FIA 65 D STR	148H3091						
65	2½	FIA-SS 65 D STR 52BAR	148H3291						
65	2½	FIA 65 A STR	148H3103						
80	3	FIA 80 D ANG	148H3058	148H3119	148H3120	148H3121	148H3181	148H3186	148H3191
80	3	FIA 80 A ANG	148H3070						
80	3	FIA 80 D STR	148H3092						
80	3	FIA 80 A STR	148H3104						
100	4	FIA 100 D ANG	148H3059	148H3132	148H3140	148H3146	148H3182	148H3187	148H3192
100	4	FIA 100 A ANG	148H3071						
100	4	FIA 100 D STR	148H3093						
100	4	FIA 100 A STR	148H3105						
125	5	FIA 125 D ANG	148H3060	148H3133	148H3141	148H3147	148H3183	148H3188	148H3193
125	5	FIA 125 A ANG	148H3072						
125	5	FIA 125 D STR	148H3094						
125	5	FIA 125 A STR	148H3106						
150	6	FIA 150 D ANG	148H3061	148H3134	148H3142	148H3148	148H3226	-	-
150	6	FIA 150 A ANG	148H3073						
150	6	FIA 150 D STR	148H3095						
150	6	FIA 150 A STR	148H3107						
200	8	FIA 200 D ANG	148H3062	148H3135	148H3143	148H3149	148H3297	-	-
200	8	FIA 200 A ANG	148H3074						
200	8	FIA 200 D STR	148H3096						
200	8	FIA 200 A STR	148H3108						
250	10	FIA 250 D ANG	148H3171	148H3136	148H3175	-	-	-	-
250	10	FIA 250 A ANG	148H3173						
300	12	FIA 300 A ANG	148H3174	148H3137	148H3176	-	-	-	-

D = Butt-weld DIN
A = Butt-weld ANSI

ANG = Angle-way
STR = Straight-way

Accessories

Part	Accessory for	Code number	
Magnet insert	FIA 65-100	148H3447	
	FIA 125-200	148H3448	
Part	Accessory for	Code number	
	Filter element μ 150 with removable element μ 50 for the first start up	FIA 15-20 FIA 25-40	148H3301 148H3302
Part	Accessory for	Code number	
	Filter bag	FIA 50	148H3150
		FIA 65	148H3151
		FIA 80	148H3152
		FIA 100	148H3153
		FIA 125	148H3154
		FIA 150	148H3155
FIA 200		148H3156	
Part	Accessory for	Code number	
	Purge valve complete Blind nut with gasket	FIA 50 - 300	148B3745 148H3450

