

SC10G

Universal Compressor

R134a

220-240V 50Hz

Data Sheet (Replaces CD.44.C5.02)

General

Compressor	SC10G
Code number	104G8000

Application

Application		LBP/HBP
Evaporating temperature range	°C	-35 to 15
Voltage range	V/Hz	LBP: 187 - 254 /50
		LBP: 198 - 254 /60
		HBP: 198 - 254 /50
Motor type		RSIR/CSIR
Max. ambient temperature	°C	43
Comp. cooling at ambient temp.	32°C	LBP: F ₁
		HBP: F ₂
	38°C	LBP: F ₁
		HBP: F ₂
43°C	LBP: F ₁	
	HBP: F ₂	

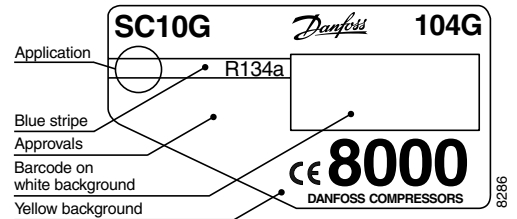

- S = Static cooling normally sufficient
- O = Oil cooling
- F₁ = Fan cooling 1.5 m/s
(compressor compartment temperature equal to ambient temperature)
- F₂ = Fan cooling 3.0 m/s necessary

Design

Displacement	cm ³	10.29
Oil quantity	cm ³	550 (500 on comp. with oil cooler)
Maximum refrigerant charge	g	1300
Free gas vol. in compressor	cm ³	1510
Weight without electrical equipment	kg	12.1

Motor

Motor size	watt	250
LRA (rated after 4 sec. UL984) LST/HST	A	10.2/11.1
Cut-in current LST/HST	A	14.6/11.1
Resistance, main and start winding (25°C)	Ω	8.5/14.1
Approvals		EN 60335-2-34

Dimensions

Height	mm	A	199
		B	193
		B1	173
		B2	90
Suction connector	location/I.D. mm	C	8.2 ±0.09
Process connector	location/I.D. mm	D	6.2 ±0.09
Discharge connector	location/I.D. mm	E	6.2 ±0.09
Compressors on a pallet	pcs.		80

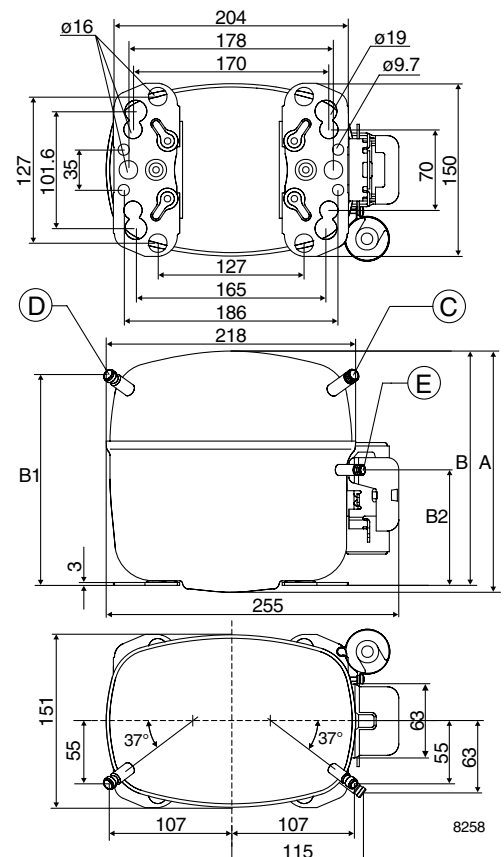

Capacity (EN 12900/CECOMAF)

Comp. \ °C	-35	-30	-25	-23.3	-20	-15	-10	-5	0	5	7.2	10	15
SC10G	23	60	113	135	183	268	369	486	618	764	833	925	1100

watt

Capacity (ASHRAE)

Comp. \ °C	-35	-30	-25	-23.3	-20	-15	-10	-5	0	5	7.2	10	15
SC10G	29	74	139	166	225	331	456	600	764	946	1032	1147	1367

watt

Power consumption

Comp. \ °C	-35	-30	-25	-23.3	-20	-15	-10	-5	0	5	7.2	10	15
SC10G	93	139	181	195	220	256	290	322	353	383	396	412	441

watt

Current consumption

Comp. \ °C	-35	-30	-25	-23.3	-20	-15	-10	-5	0	5	7.2	10	15
SC10G	1.29	1.34	1.41	1.44	1.50	1.61	1.72	1.85	1.98	2.12	2.18	2.26	2.40

A

COP (EN 12900/CECOMAF)

Comp. \ °C	-35	-30	-25	-23.3	-20	-15	-10	-5	0	5	7.2	10	15
SC10G	0.25	0.43	0.63	0.69	0.83	1.05	1.27	1.51	1.75	2.00	2.11	2.25	2.49

W/W

COP (ASHRAE)

Comp. \ °C	-35	-30	-25	-23.3	-20	-15	-10	-5	0	5	7.2	10	15
SC10G	0.31	0.53	0.77	0.85	1.02	1.29	1.57	1.86	2.16	2.47	2.61	2.78	3.10

W/W

Test conditions	EN 12900/CECOMAF	ASHRAE
Condensing temperature	55°C	55°C
Ambient and suction gas temp.	32°C	32°C
Liquid temperature	55°C	32°C
Fan cooling, 220V 50Hz		

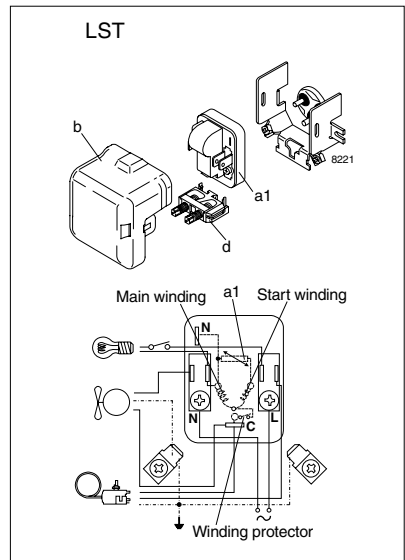
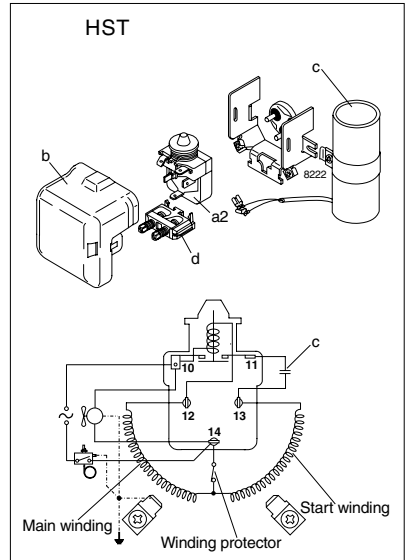

Accessories

Devices	Fig.	SC10G	
PTC starting device	6.3 mm spades	a1	103N0002
Starting relay		a2	117U6002
Cover		b	103N2009
Starting capacitor 80 µF		c	117U5017
Cord relief		d	103N1004
Mounting accessories			
Bolt joint for one compressor			118-1917
Bolt joint in quantities			118-1918
Snap-on in quantities			118-1919

Danfoss can accept no responsibility for possible errors in catalogues, brochures and other printed material. Danfoss reserves the right to alter its products without notice. This also applies to products already on order provided that such alterations can be made without subsequential changes being necessary in specifications already agreed. All trademarks in this material are property of the respective companies. Danfoss and the Danfoss logotype are trademarks of Danfoss A/S. All rights reserved.

