

Technical brochure

Stop Valves for Industrial Refrigeration SVA, SVA-ST, SVA-HS & SVA-SS

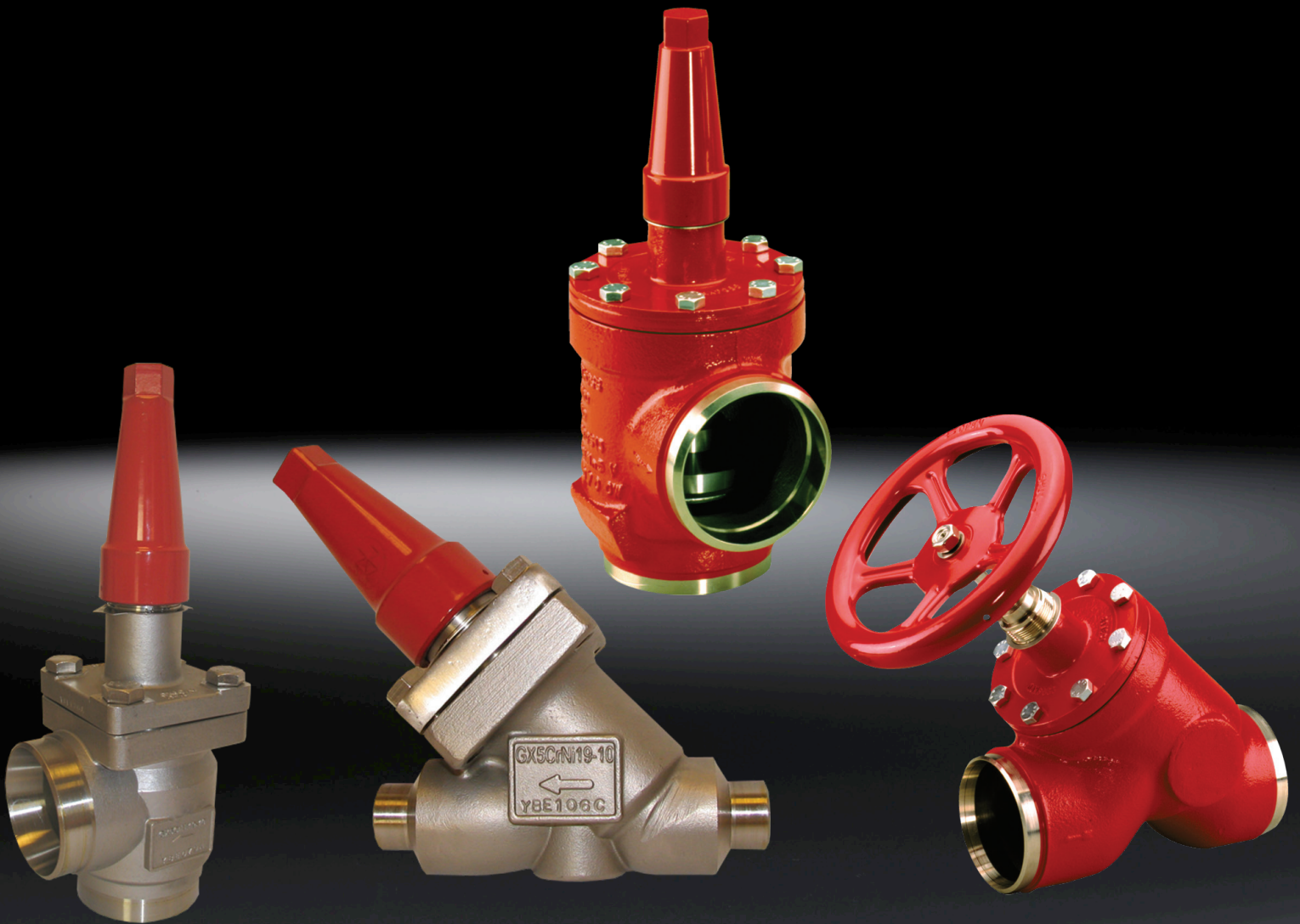

Contents

	Page
Introduction.....	3
Features.....	3
Additional features for high spec. version (SVA-HS).....	4
Design.....	4
Technical data.....	5
Connections:	
SVA-ST, SS and HS.....	5
SVA 6-10.....	6
Material specification.....	7
Dimensions and weights.....	13
Ordering.....	21

Introduction

SVA are angleway and straightway stop valves which are designed to meet all industrial refrigeration application requirements.

The valves are designed to give favourable flow characteristics and are easy to dismantle and repair when necessary. The valve cone is designed to ensure perfect closing.



Features

- Applicable to all common refrigerants including R717 and non corrosive gases/ liquids dependent on sealing material compatibility
- Optional accessories:
 - Heavy duty industrial hand wheel for frequent operation
 - Cap for infrequent operation
 - Lock washers for the stop valves subjected to high vibrations/pulsations
- Available in angleway and straightway versions with standard bonnet or extended bonnet (15-100) for insulated systems
- Each valve type is clearly marked with type, size and performance range
- The valves and caps are prepared for sealing, to prevent operation by unauthorized persons, using a seal wire
- Internal metal backseating
 - DN 6 - 65 (1/4 - 2 1/2 in.)
 - Internal PTFE backseating
 - DN 80 - 200 (3 - 8 in.)
- Can accept flow in both directions
- Standard bonnet is suitable for installation in normal insulated systems
- Housing and bonnet material for SVA-ST and HS are in low temperature steel according to requirements of the Pressure Equipment Directive and other international classification authorities

SVA-SS housing is made of special cold resistant stainless steel approved for low temperature operations.

- Stainless steel bolts.
- Maximum allowable working pressure and temperature range

Standard applications

SVA-ST	40 bar (580 psi) at -50°C/+150°C (-58°F/+302°F)
SVA-HS	40 bar (580 psi) at -60°C/+150°C (-76°F/+302°F)
SVA-SS (DN 15-65)	52 bar (754 psi) at -60°C/+50°C (-76°F/+122°F)
SVA-SS (DN 80-125)	50 bar (725 psi) at -60°C/+50°C (-76°F/+122°F)

High pressure applications

SVA-ST (DN 15-65)	52 bar (754 psi) at -50°C/+50°C (-58°F/+122°F)
SVA-ST (DN 80-200)	50 bar (725 psi) at -50°C/+50°C (-58°F/+122°F)

Please note:

SVA-ST with PS > 40 bar have separate code numbers (see page 24).

SVA-SS, ST (high pressure):
See the relation between PS and temperature for PS > 40 bar in the curves below.

- Classification: DNV, LR, SAQ, CRN, BV etc.
To get an updated list of certification on the products please contact your local Danfoss Sales Company

Pressure and temperature range

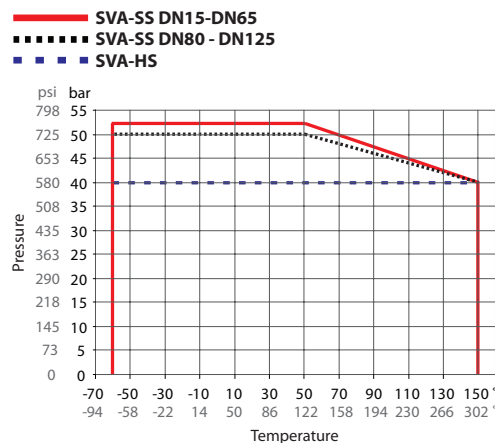
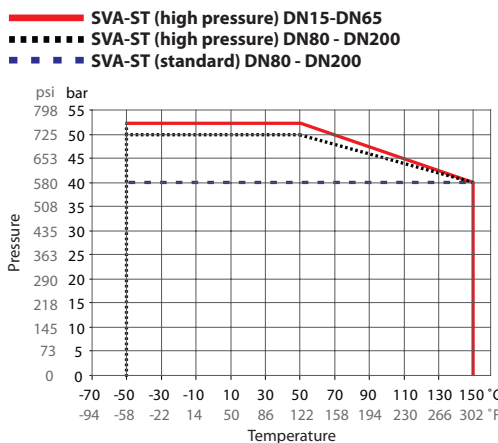

Additional features for high spec. version (SVA-HS)

- Low temperature version with extended bonnet for insulated low temperature applications.
- Can be used in chemical and petro-chemical applications.
- Stainless steel packing gland with special teflon low temperature spindle seal.
- Temperature range:
High spec. version
 -60/+150°C (-76/+302°F)

Design
Connections

Available with the following connections:

- Butt-weld DIN (EN 10220)
- Butt-weld ANSI (B 36.10 Schedule 80),
 - DN 6 - 40 (1/4 - 1 1/2 in.)
- Butt-weld ANSI (B 36.10 Schedule 40),
 - DN 50 - 200 (2 - 8 in.)
- Socket Weld (ANSI B 16.11),
 - DN 15 - DN 50 (1/2 - 2 in.)
- Outside pipe thread
 - G 1/2 in. - G 7/8 in. (ISO 228/1)
- FPT Female Pipe Thread, NPT (ANSI/ASME B 1.20.1),
 - DN 15 - 32 (1/2 - 1 1/4 in.)

Housing

Made of special, cold resistant steel (SVA-ST, HS) or stainless steel (SVA-SS) approved for low temperature operations.

Valve cone

The valve cone can be turned on the spindle, thus there will be no friction between the cone and the seat, when the valve is opened and closed. A teflon tightening ring provides perfect sealing at a minimum closing momentum.

Spindle

Made of polished stainless steel, ideal for O-ring sealing.

Packing gland

Standard version (SVA 6-10 and SVA-ST):

The standard packing gland ensures a perfect tightness in the range: -50/+150°C (-58/+302°F). The packing glands are equipped with a scraper ring to prevent penetration of dirt and ice into the packing gland.

Stainless steel version (SVA-SS):

The stainless steel packing gland comprises a spring loaded seal packing gland which ensures a perfect tightness in the range: -60/+150°C (-76/+302°F).

The packing glands are equipped with a scraper ring to prevent penetration of dirt and ice into the packing gland.

High spec. version (SVA-HS):

This comprises a threaded bush equipped with teflon wear rings to prevent damage of the spindle surface. In addition, a scraper ring is mounted to prevent dirt and ice to penetrate into the packing gland. The sealing consists of conical shaped teflon rings supported by metal bushings and ensures a perfect tightness in the range: -60°C/+150°C (-76°F/+302°F).

Pressure Equipment Directive (PED)

SVA-ST and SVA-HS valves are approved according to the European standard specified in the Pressure Equipment Directive and are CE marked.

For further details / restrictions - see Installation Instruction.

Installation

 It is recommended that the valves be installed in the direction of flow indicated by the arrow on the valve body. The valve can be installed in the opposite direction but this slightly reduces the k_v -value (C_v -value).

The valve is designed to withstand high internal pressure. However, the piping system in general should be designed to avoid liquid traps and reduce the risk of hydraulic pressure caused by thermal expansion.

For further information refer to installation instructions for SVA.

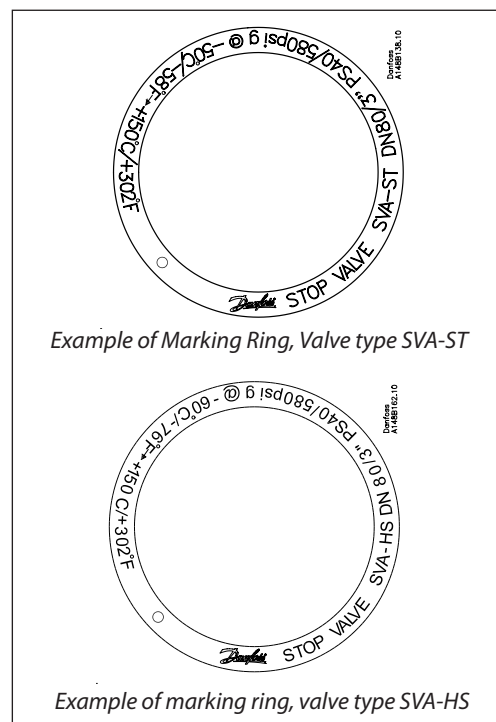

SVA			
Nominal bore	DN ≤ 25 mm (1 in.)	DN32-80 mm (1 1/4 - 3 in.)	DN100 - 200 mm (4-8 in.)
Classified for	Fluid group I		
Category	Article 3, paragraph 3	II	III

Technical data

- Refrigerants (SVA 6-10 and SVA-ST)
Applicable to all common non flammable refrigerants including R717 and non corrosive gases/liquids dependent on sealing material compatability. For further information please see installation instruction for SVA.
- Refrigerants (SVA-HS)
Applicable to all common refrigerants including flammable hydrocarbons and all non-corrosive gases/liquids. For further information please see installation instruction for SVA-HS.
- Temperature range
Standard version (ST):
-50/+150°C (-58/+302°F).
High spec. and stainless steel version (HS and SS):
-60/+150°C (-76/+302°F).
- Pressure range
The valves are designed for max. working pressure 40 bar g (580 psi g). Valves for higher working pressure are available on request.
SVA-SS are designed for max. working pressure 52 bar (754 psi g).

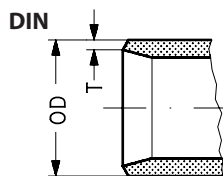
**Connections
SVA-ST, SS and HS**

Size mm	Size in.	OD mm	T mm	OD in.	T in.			k_v -angle m ³ /h	k_v -straight m ³ /h	C_v -angle USgal/min	C_v -straight USgal/min
---------	----------	-------	------	--------	-------	--	--	-----------------------------------	--------------------------------------	---------------------------	------------------------------

Butt-weld DIN (EN 10220)

6	1/4	13.5	2.3	0.531	0.091			2.9	2.0	3.4	2.4
10	3/8	17.2	2.3	0.677	0.091			4.5	3.2	5.2	3.6
15	1/2	21.3	2.3	0.839	0.091			7.0	4.9	8.1	5.7
20	3/4	26.9	2.3	1.059	0.091			14.6	10.2	16.9	11.8
25	1	33.7	2.6	1.327	0.103			24.8	17.4	28.8	20.2
32	1 1/4	42.4	2.6	1.669	0.102			42.6	29.8	49.4	34.6
40	1 1/2	48.3	2.6	1.902	0.103			45.2	31.6	52.4	36.7
50	2	60.3	2.9	2.37	0.11			80	65	93	76
65	2 1/2	76.1	2.9	3	0.11			120	97	140	113
80	3	88.9	3.2	3.50	0.13			182	152	211	176
100	4	114.3	3.6	4.50	0.14			313	278	363	323
125	5	139.7	4.0	5.50	0.16			514	470	596	545
150	6	168.3	4.5	6.63	0.18			785	597	911	693
200	8	219.1	6.3	8.63	0.25			1168	1024	1355	1188

Size mm	Size in.	OD mm	T mm	OD in.	T in.			k_v -angle m ³ /h	k_v -straight m ³ /h	C_v -angle USgal/min	C_v -straight USgal/min
---------	----------	-------	------	--------	-------	--	--	-----------------------------------	--------------------------------------	---------------------------	------------------------------

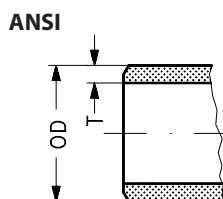
Butt-weld ANSI (B 36.10 Schedule 80)

6	1/4	13.5	3.0	0.531	0.118			2.9	2.03	3.4	2.4
10	3/8	17.2	3.2	0.677	0.126			4.5	3.15	5.2	3.6
15	1/2	21.3	3.7	0.839	0.146			7.0	4.9	8.1	5.7
20	3/4	26.9	4.0	1.059	0.158			14.6	10.2	16.9	11.8
25	1	33.7	4.6	1.327	0.181			24.8	17.4	28.8	20.2
32	1 1/4	42.4	4.9	1.669	0.193			42.6	29.8	49.4	34.6
40	1 1/2	48.3	5.1	1.902	0.201			45.2	31.6	52.4	36.7

Butt-weld ANSI (B 36.10 Schedule 40)

50	2	60.3	3.9	2.37	0.15			80	65	93	76
65	2 1/2	73.0	5.2	2.87	0.20			120	97	140	113
80	3	88.9	5.5	3.50	0.22			182	152	211	176
100	4	114.3	6.0	4.50	0.24			313	278	363	323
125	5	141.3	6.6	5.56	0.26			514	470	596	545
150	6	168.3	7.1	6.63	0.28			785	597	911	693
200	8	219.1	8.2	8.63	0.32			1168	1024	1355	1188

**Connections
SVA-ST, SS and HS**

Size mm	Size in.	ID mm	T mm	ID in.	T in.	L mm	L in.	k_v -angle m ³ /h	k_v -straight m ³ /h	C_v -angle USgal/min	C_v -straight USgal/min
------------	-------------	----------	---------	-----------	----------	---------	----------	-----------------------------------	--------------------------------------	---------------------------	------------------------------

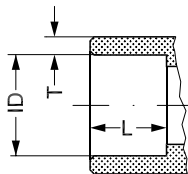
SOC

Socket welding ANSI (B 16.11)

15	½	21.8	6.0	0.858	0.235	10	0.39	7.0	4.9	8.1	5.7
20	¾	27.2	4.6	1.071	0.181	13	0.51	10.0	7.0	11.9	8.1
25	1	33.9	7.2	1.335	0.284	13	0.51	24.8	17.4	28.8	20.2
32	1¼	42.7	6.1	1.743	0.240	13	0.51	42.6	29.8	49.4	34.6
40	1½	48.8	6.6	1.921	0.260	13	0.51	45.2	31.6	52.4	36.7
50	2	61.2	6.2	2.41	0.24	16	0.63	80	65	93	76

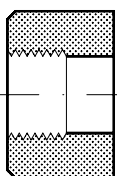
Size mm	Size in.	Inside pipe thread			k_v -angle m ³ /h	k_v -straight m ³ /h	C_v -angle USgal/min	C_v -straight USgal/min
------------	-------------	--------------------	--	--	-----------------------------------	--------------------------------------	---------------------------	------------------------------

FPT

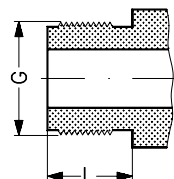
FPT inside pipe thread, NPT (ANSI/ASME B 1.20.1)

15	½	(½ × 14 NPT)			8.5	6.0	9.9	7.0
20	¾	(¾ × 14 NPT)			10	7.0	11.6	8.1
25	1	(1 × 11.5 NPT)			32	22.4	37.1	26.0
32	1¼	(1¼ × 11.5 NPT)			36	25.2	41.8	29.3

Connections - SVA 6 and SVA-ST 15
T

Size mm	Size in.	Outside pipe thread	L mm	L in.	K_v -angle m ³ /h	K_v -str. m ³ /h	C_v -angle USgal/min	C_v -str USgal/min
------------	-------------	---------------------	---------	----------	-----------------------------------	----------------------------------	---------------------------	-------------------------

T outside pipe thread, (ISO 228/1)

6	¼	G ½	16	0.63	2.5	2.0	2.9	2.0
15	¾ - ½	G 7/8	19	0.76	7.0	4.9	8.1	5.7

Nipples for T outside pipe thread, (ISO 228/1)

Size mm	Size in.	OD mm	T mm	OD in.	T in.	L mm	L in.	Inside pipe thread			
------------	-------------	----------	---------	-----------	----------	---------	----------	-----------------------	--	--	--

ND welding nipples, (DIN 2448)

6	¼	13.5	2.3	0.531	0.091	60	2.36	G ½			
10	¾	17.2	2.3	0.677	0.091	50	1.97	G 7/8			
15	½	21.3	2.3	0.852	0.091	50	1.97	G 7/8			

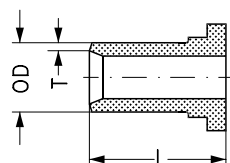
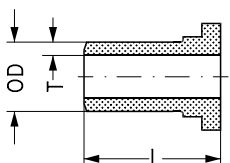
ND

NA

Size mm	Size in.	OD mm	T mm	OD in.	T in.	L mm	L in.	Inside pipe thread			
------------	-------------	----------	---------	-----------	----------	---------	----------	-----------------------	--	--	--

NA welding nipples, ANSI (B 36.10 Schedule 80)

6	¼	13.5	3.0	0.531	0.118	60	2.36	G ½			
10	¾	17.2	3.2	0.677	0.126	50	1.97	G 7/8			
15	½	21.3	3.7	0.852	0.198	50	1.97	G 7/8			

Material specification

SVA-ST 6-10 (1/4 - 3/8 in.)

SVA-ST and SVA-SS 15-20 (1/2 - 3/4 in.)

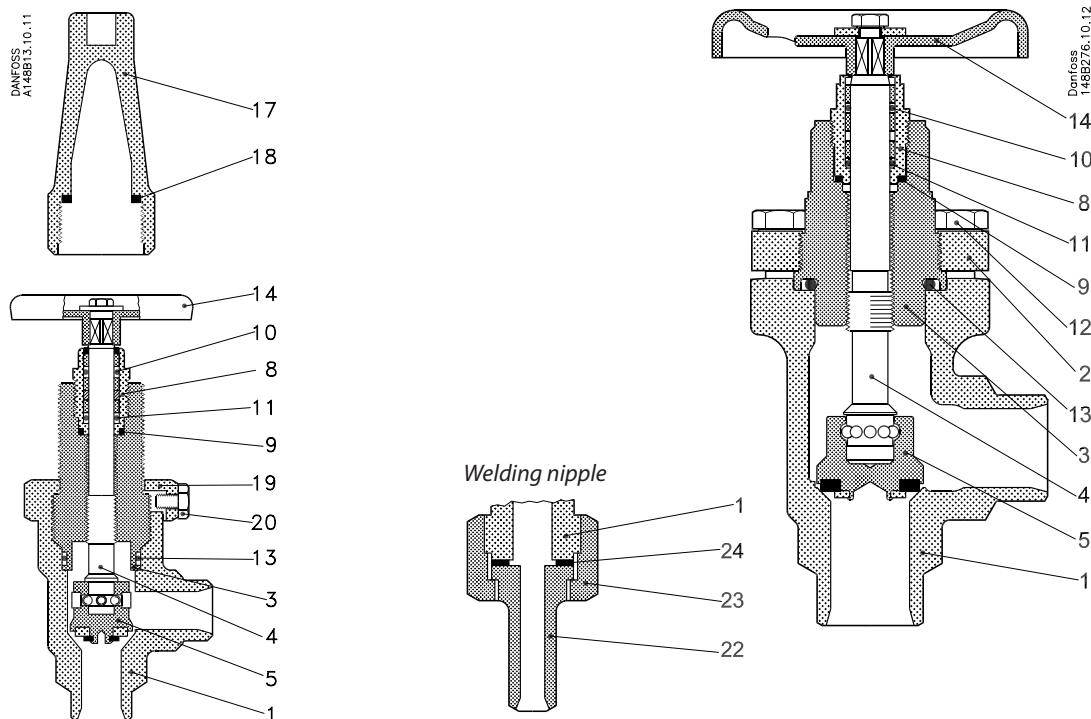

No.	Part	Material	EN	ISO	ASTM
1	Housing	Steel	G20Mn5QT, 10213-3 ----- P285QH+QT, 10222-4		LCC, A352 ----- LF2, A350
		Stainless steel (SVA-SS)	X8CrNi18-10, 10088		AISI 304
2	Bonnet, Flange	Steel	G20Mn5QT, 10213-3 ----- P285QH+QT, 10222-4		LCC, A352 ----- LF2, A350
		Stainless steel (SVA-SS)	X8CrNi18-10, 10088		AISI 304
3	Bonnet, Insert	Steel	11SMn30 10087	Type 2 R 683/9	AISI 1213
		Stainless steel (SVA-SS)			
4	Spindle	Stainless steel	X8CrNi18-9 10088 DIN 17440 (SVA-SS only)	Type 17 683/13	AISI 303
5	Cone	Steel	11SMn30 10087	Type 2 R 683/9	AISI 1213
8	Packing gland	Stainless steel	X8CrNi18-9 10088	Type 17 683/13	AISI 303
9	Packing washer	Aluminium			
10	O-ring	Cloroprene (Neoprene)			
11	O-ring (SVA-ST)	Cloroprene (Neoprene)			
	Spring loaded Teflon ring (SVA-SS)	PTFE			
12	Bolts	Stainless steel	A2-70	A2-70	Type 308
13	O-ring	Cloroprene (Neoprene)			
14	Handwheel	Steel			
17	Cap	Aluminium			
18	Gasket f. cap	Nylon			
19	Locking nut	Steel			
20	Screw	Steel			
22	Welding nipple	Steel	S235JRG2 10025	Fe260B, 630	Grade C, A 283
23	Nut	Steel	11SMn30 10087	Type 2 R 683/9	AISI 1213
24	Packing washer	Non-asbestos			

Material specification

SVA-ST, SS 25-40 (1 - 1½ in.)

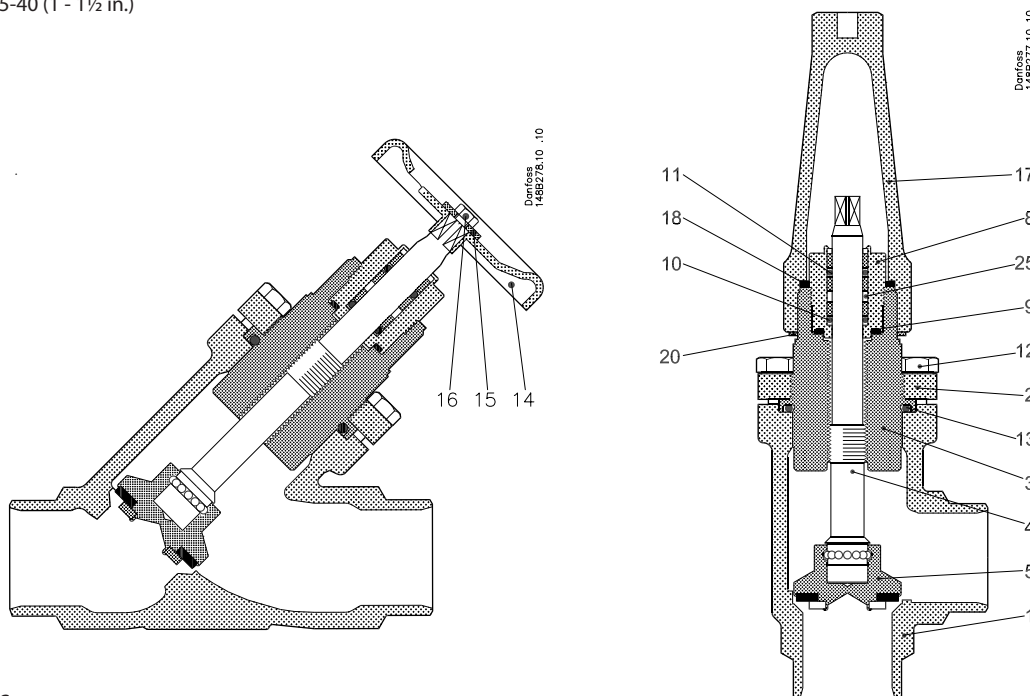

SVA-ST, SS

No.	Part	Material	EN	ISO	ASTM
1	Housing	Steel	G20Mn5QT, 10213-3 ----- P285QH+QT, 10222-4		LCC, A352 ----- LF2, A350
		Stainless steel (SVA-SS)	X5CrNi18-10, 10088		AISI 304
2	Bonnet, flange	Steel	G20Mn5QT, 10213-3 ----- P285QH+QT, 10222-4		LCC, A352 ----- LF2, A350
		Stainless steel (SVA-SS)	X5CrNi18-10, 10088		AISI 304
3	Bonnet, Insert	Steel	115Mn30 10087	Type 2 R 683/9	AISI 1213
		Stainless steel (SVA-SS)			
4	Spindle	Stainless steel	X8CrNiS18-9 10088 DIN 17440 (SVA-SS only)	Type 17 683/13	AISI 303
5	Cone Cone seal	Steel	115Mn30 10087	Type 2, R 683/9	AISI 1213
		Teflon (PTFE)			
8	Packing gland	Stainless steel	X8CrNiS18-9 10088	Type 17 683/13	AISI 303
9	O-ring	Cloroprene (Neoprene)			
10	O-ring (SVA-ST)	Cloroprene (Neoprene)			
	Spring loaded Teflon ring (SVA-SS)	PTFE			
11	O-ring	Cloroprene (Neoprene)			
12	Bolts	Stainless steel	A2-70	A2-70	Type 308
13	O-ring	Cloroprene (Neoprene)			
14	Hand wheel	Steel			
15	Washer	Stainless steel (A2)			
16	Screw	Stainless steel (A2)			
17	Cap	Aluminium			
18	Gasket for cap	Nylon			
20	Identification ring	Stainless steel			

Material specification

SVA-ST, SS 50-65 (2 - 2½ in.)

SVA-ST,SS 50-65 (2-2½ in.) and SVA-SS 80-125 (3 - 5 in.)

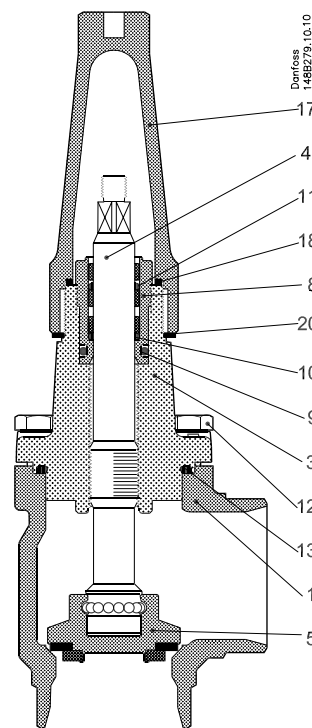
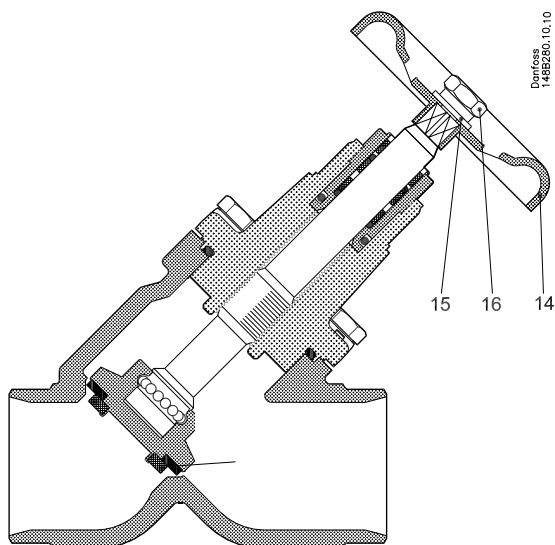

SVA-ST, SS

No.	Part	Material	EN	ISO	ASTM
1	Housing	Steel	G20Mn5QT, 10213-3 ----- P285QH+QT, 10222-4		LCC, A352 ----- LF2, A350
		Stainless steel (SVA-SS 50-65) Stainless steel (SVA-SS 80-125)	X5CrNi18-10, 10088 GX5CrNi 18-10, 10213-4		AISI 304
3	Valve bonnet	Steel	G20Mn5QT, 10213-3 ----- P285QH+QT, 10222-4		LCC, A352 ----- LF2, A350
		Stainless steel (SVA-SS 50-65) Stainless steel (SVA SS 80-125)	X5CrNi18-10, 10088 GX5CrNiMo 19-11, 10213-4		AISI 304
4	Spindle	Stainless steel	X8CrNiS18-9 10088 DIN 17440 (SVA-SS only)	Type 17 R 683/13	AISI 303
5	Cone Cone seal	Steel Teflon (PTFE)	11SMn30 10087	Type 2, R 683/13	AISI 1213
8	Packing gland	Stainless steel	X8CrNiS18-9 10088	Type 17 R 683/13	AISI 303
9	O-ring	Cloroprene (Neoprene)			
10	O-ring (SVA-ST)	Cloroprene (Neoprene)			
	Spring loaded Teflon ring (SVA-SS)	PTFE			
11	O-ring	Cloroprene (Neoprene)			
12	Bolts	Stainless steel	A2-70	A2-70	Type 308
13	O-ring	Cloroprene (Neoprene)			
14	Hand wheel	Steel			
15	Washer	Stainless steel (A2)			
16	Nut	Stainless steel (A2)			
17	Cap	Aluminium			
18	Gasket for cap	Nylon (PA 6)			
20	Identification ring	Stainless steel			

Material specification

SVA-ST 80 - 200 (3 - 8 in.)

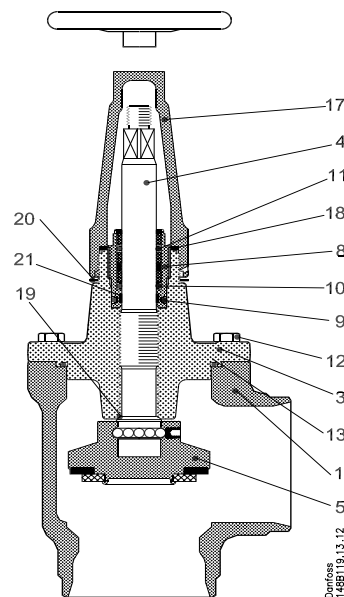
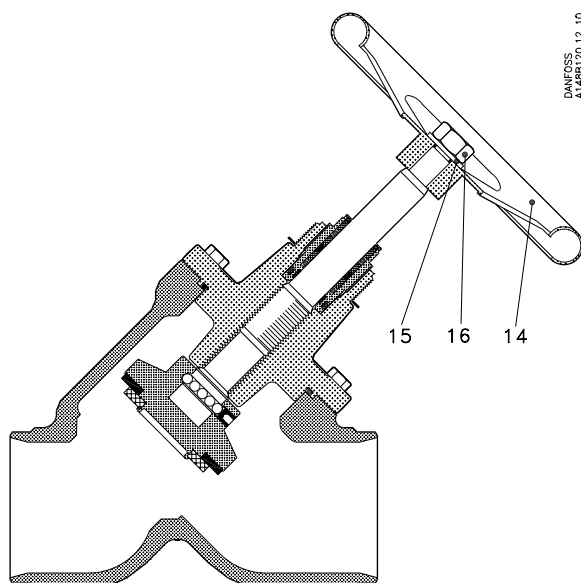

SVA-ST

No.	Part	Material	EN	ISO	ASTM
1	Housing	Steel	G20Mn5QT 10213-3		LCC A352
3	Valve bonnet	Steel	G20Mn5QT, 10213-3 ----- P285QH+QT, 10222-4		LCC, A352 ----- LF2, A350
4	Spindle	Stainless steel	X5CrNi18-10 10088	Type 11, R 683/13	AISI 304, A276
5	Cone Cone seal	Steel Teflon (PTFE)	115Mn30 10087	Type 2, R 683/9	AISI 1213
8	Packing gland	Stainless steel	X8CrNiS18-9 10088	Type 17 R 683/13	AISI 303
9	O-ring	Cloroprene (Neoprene)			
10	O-ring	Cloroprene (Neoprene)			
11	O-ring	Cloroprene (Neoprene)			
12	Bolts	Stainless steel	A2-70	A2-70	Type 308
13	O-ring	Cloroprene (Neoprene)			
14	Hand wheel	Steel			
15	Washer	Stainless steel			
16	Nut	Stainless steel			
17	Cap	Aluminium			
18	Gasket for cap	Nylon (PA 6)			
19	Soft backseat	Teflon (PTFE)			
20	Identification ring	Stainless steel			
21	Wear ring	Teflon (PTFE)			

Material specification

SVA-HS 15 - 65 (½ - 2½ in.)

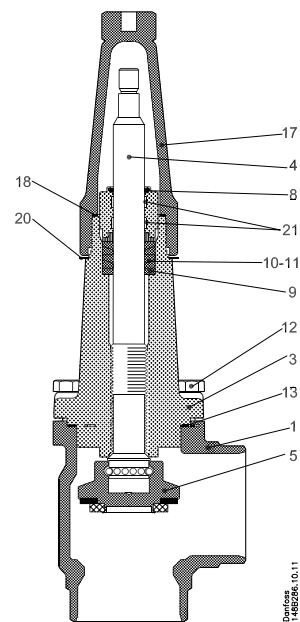
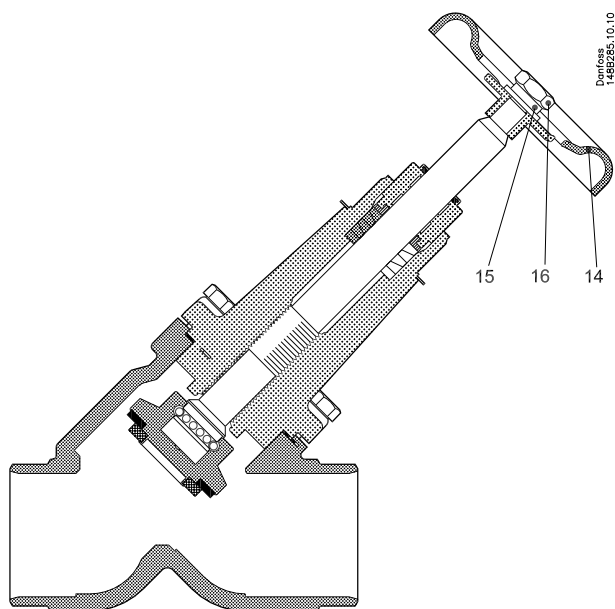

SVA-HS

No.	Part	Material	EN	ISO	ASTM
1	Housing	Steel	G20Mn5QT, 10213-3 ----- P285QH+QT, 10222-4		LCC, A352 ----- LF2, A350
3	Valve bonnet	Steel	G20Mn5QT, 10213-3 ----- P285QH+QT, 10222-4		LCC, A352 ----- LF2, A350
4	Spindle	Stainless steel	X2CrNiMo17-12-2 10088		AISI 316
5	Cone Cone seal	Steel PTFE	115Mn30 10087	Type 2, R 683/9	AISI 1213
8	Packing gland	Stainless steel	X8CrNiS18-9 10088	Type 17 R 683/13	AISI 303
9	Washer	Cast iron			
10-11	Seal ring	PTFE			
12	Bolts	Stainless steel	A2-70	A2-70	Type 308
13	Gasket	Fiber, Non-asbestos			
14	Hand wheel	Steel			
15	Washer	Stainless steel			
16	Screw/Nut	Stainless steel			
17	Cap	Aluminium			
18	Gasket for cap	Nylon (PA6)			
20	Identification ring	Stainless steel			
21	Wear ring	PTFE (Teflon)			

Material specification

SVA-HS 80 - 200 (3 - 8 in.)

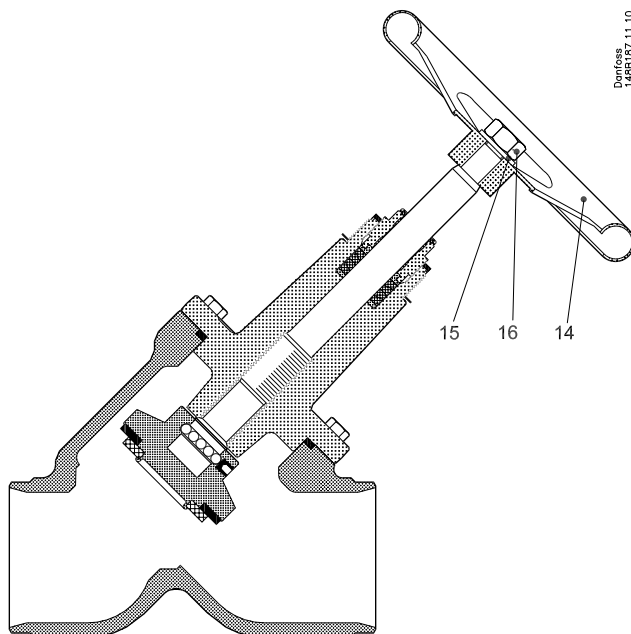

Danfoss
148B187.11.10

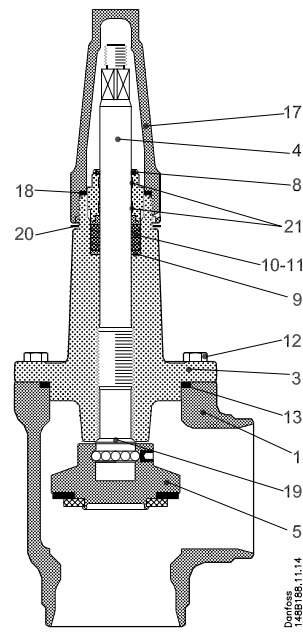

Danfoss
148B188.11.14

SVA-HS

No.	Part	Material	EN	ISO	ASTM
1	Housing	Steel	G20Mn5QT 10213-3		LCC A352
3	Valve bonnet	Steel	G20Mn5QT, 10213-3 ----- P285QH+QT, 10222-4		LCC, A352 ----- LF2, A350
4	Spindle	Stainless steel	X2CrNiMo17-12-2 10088		AISI 316
5	Cone Cone seal	Steel PTFE	115Mn30 10087	Type 2, R 683/9	AISI 1213
8	Packing gland	Stainless steel	X8CrNiS18-9 10088	Type 17 R 683/13	AISI 303
9	Washer	Cast iron			
10-11	Seal ring	PTFE			
12	Bolts	Stainless steel	A2-70	A2-70	Type 308
13	Gasket	Fiber, Non-asbestos			
14	Hand wheel	Steel			
15	Washer	Stainless steel			
16	Screw/Nut	Stainless steel			
17	Cap	Aluminium			
18	Gasket for cap	Nylon (PA6)			
19	Internal soft backseating	PTFE			
20	Identification ring	Stainless steel			
21	Wear ring	PTFE			

Dimensions and weights

SVA 6 - 10 in angle execution with handwheel (SVA 121)

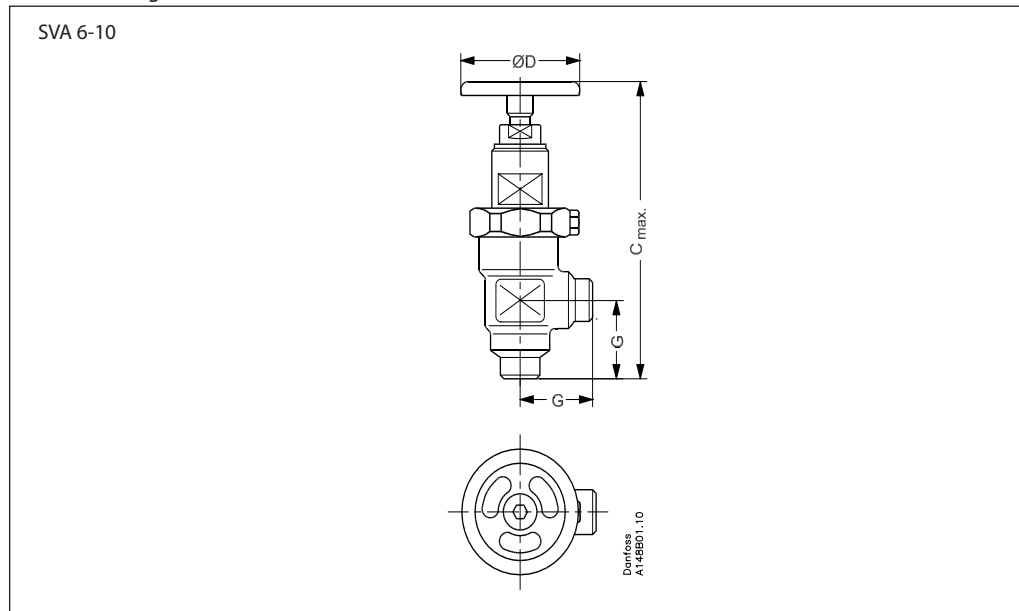

Valve size			C _{max.}	G	ØD	□H	Weight
SVA 6	mm		128	30	50		0.7 kg
	in.		5.04	1.18	1.97		
SVA 10	mm		173	45	60	60	1.4 kg
	in.		6.81	1.77	2.36	2.36	

SVA 6 - 10 in angle execution with cap (SVA 123)
or in angle execution with cap and extended bonnet (SVA 126)

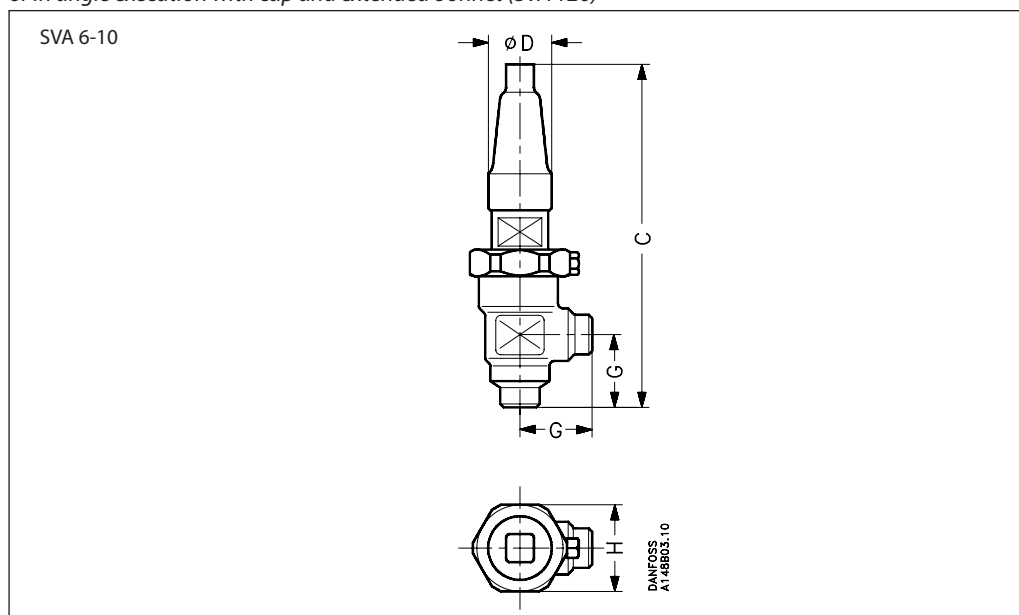

Valve size			C	G	ØD	□H	Weight
SVA 6	mm		139	30	30	48	0.8 kg
	in.		5.47	1.18	1.18	1.89	
SVA 10	mm		182	45	38	60	1.4 kg
	in.		7.17	1.77	1.50	2.36	

Specified weights are approximate values only.

Dimensions and weights

SVA 6 - 10 in straight-way execution with handwheel (SVA 221)

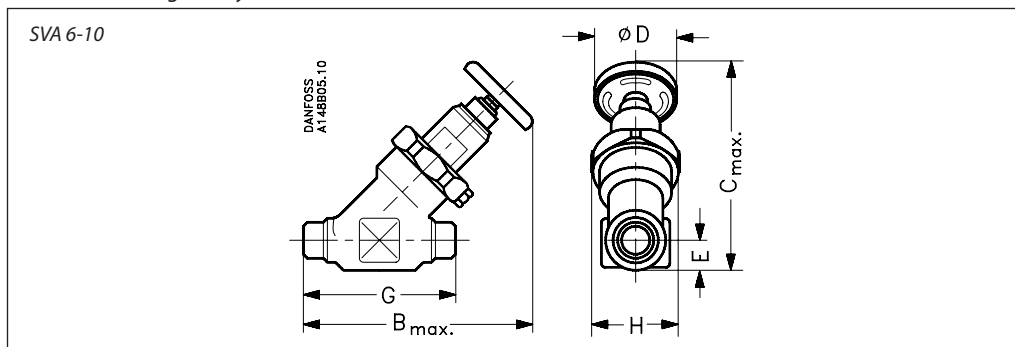

Valve size		C _{max.}	B _{max.}	E	G	ØD	□H	Weight
SVA 6	mm	110	120	13	70	50	48	0.7 kg
	in.	4.33	4.72	0.49	2.76	1.97	1.89	
SVA 10	mm	145	160	20	120	60	60	2.0 kg
	in.	5.71	6.30	0.79	4.72	2.36	2.36	

SVA 6 - 10 in straight-way execution with cap (SVA 223)
or in straight-way execution with cap and extended bonnet (SVA 226)

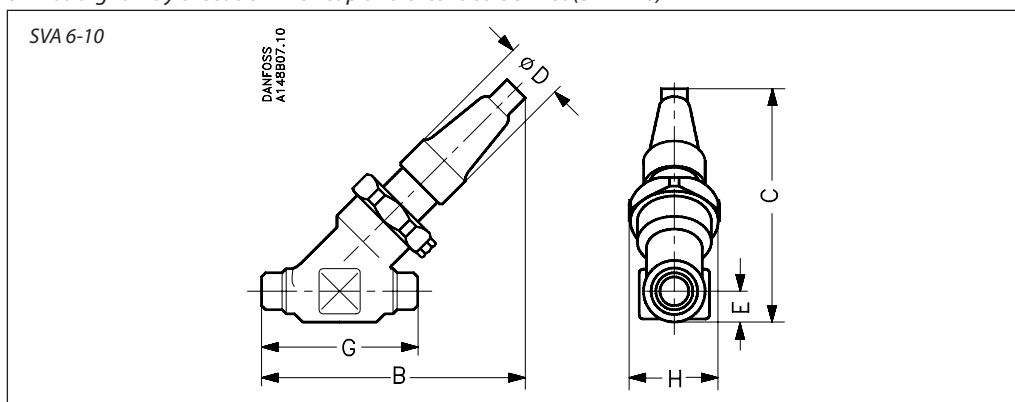

Valve size		C	B	E	G	ØD	□H	Weight
SVA 6	mm	110	120	13	70	30	48	0.8 kg
	in.	4.33	4.72	0.49	2.76	1.16	1.89	
SVA 10	mm	145	155	20	120	38	60	2.0 kg
	in.	5.71	6.10	0.79	4.72	1.50	2.36	

Specified weights are approximate values only.

Dimensions and weights

SVA 15 - 40 (½ - 1½ in.) in angleway version with cap / hand wheel

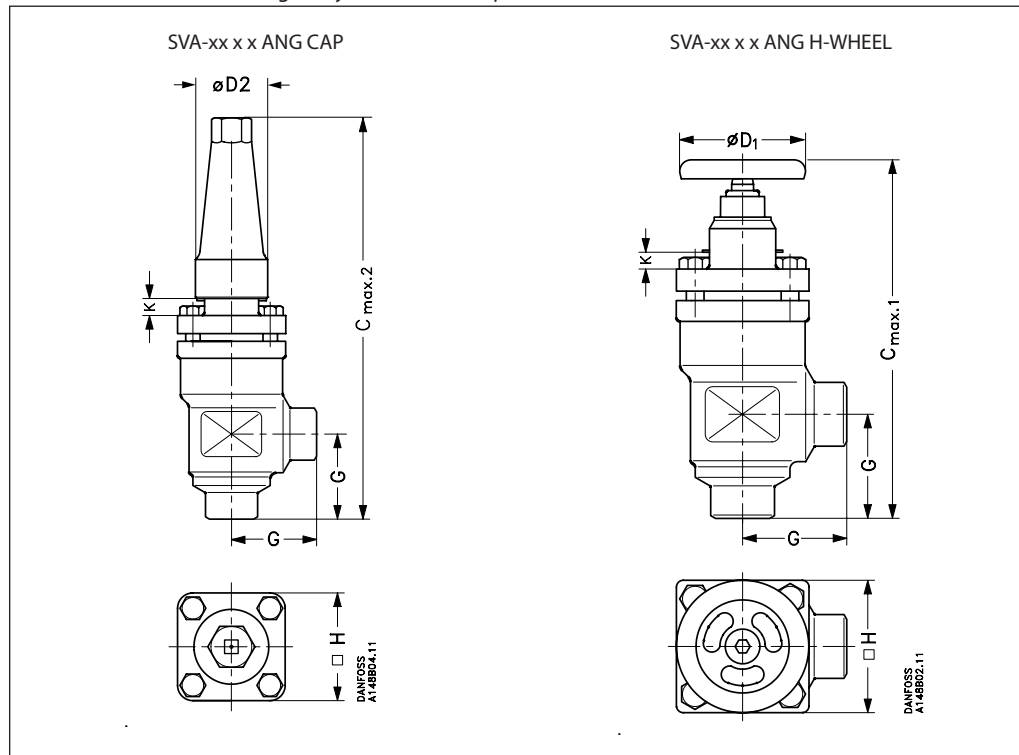

Valve size	K	C _{max.1}	C _{max.2}	G	ØD ₁	ØD ₂	□H	Weight
SVA-ST, SS								
SVA 15 - 20 mm	4	178	189	45	60	38	60	1.4 kg
SVA (½ - ¾) in.	0.16	7.00	7.44	1.77	2.36	1.5	2.36	3.1 lb
SVA 25 - 40 mm	12	234	268	55	80	50	70	2.4 kg
SVA (1 - 1½) in.	0.47	9.21	10.55	2.17	3.15	1.97	2.76	5.3 lb
SVA-ST, Socket weld								
SVA 32 - 40 mm	12	241	275	62	80	50	70	2.9 kg
SVA (1¼ - 1½) in.	0.47	9.49	10.83	2.44	3.15	1.97	2.76	6.4 lb
SVA-HS								
SVA 15 - 20 mm	63	237	248	45	60	38	60	1.4 kg
SVA (½ - ¾) in.	2.48	9.33	9.76	1.77	2.36	1.5	2.36	3.1 lb
SVA 25 - 40 mm	74	296	330	55	80	50	70	2.4 kg
SVA (1 - 1½) in.	2.91	11.65	12.99	2.17	3.15	1.97	2.76	5.3 lb
SVA-HS, Socket weld								
SVA 32 - 40 mm	74	303	337	62	80	50	70	2.9 kg
SVA (1¼ - 1½) in.	2.91	11.93	13.27	2.44	3.15	1.97	2.76	6.4 lb

Specified weights are approximate values only.

Dimensions and weights

SVA 15 - 40 (½ - 1½ in.) straightway version with cap / hand wheel

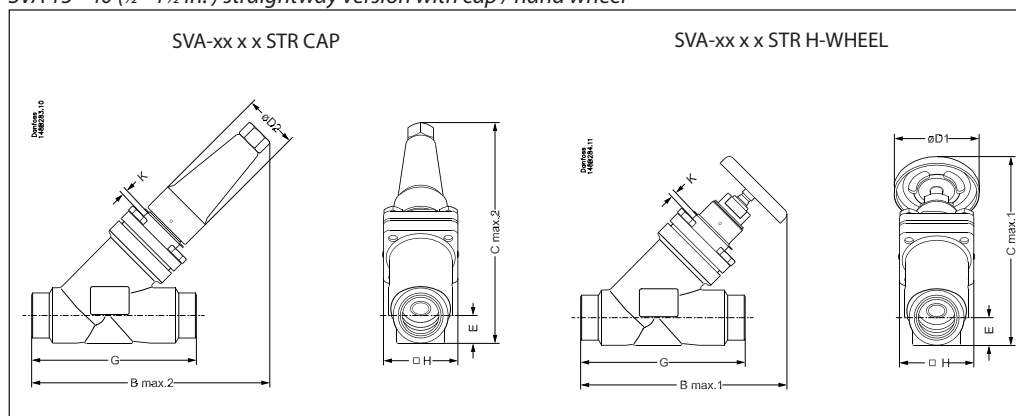

Valve size	K	C _{max.1}	C _{max.2}	B _{max.1}	B _{max.2}	E	G	ØD ₁	ØD ₂	□H	Weight
------------	---	--------------------	--------------------	--------------------	--------------------	---	---	-----------------	-----------------	----	--------

SVA-ST, SS

SVA 15 - 20	mm	4	146	141	160	156	20	120	60	38	60	2.0 kg
SVA (½ - ¾)	in.	0.16	5.74	5.55	6.30	6.14	0.79	4.72	2.36	1.50	2.36	4.4 lb
SVA 25 - 40	mm	12	199	208	212	222	26	155	80	50	70	3.0 kg
SVA (1 - 1½)	in.	0.47	7.83	8.19	8.35	8.74	1.02	6.10	3.15	1.97	2.76	6.6 lb

SVA-ST, Socket weld

SVA 32	mm	12	200	209	212	222	27.4	155	80	50	70	3.0 kg
SVA (1¼)	in.	0.47	7.87	8.23	8.35	8.74	1.08	6.10	3.15	1.97	2.76	6.6 lb
SVA 40	mm	12	204	213	212	222	31.0	155	80	50	70	3.0 kg
SVA (1½)	in.	0.47	8.03	8.39	8.35	8.74	1.22	6.10	3.15	1.97	2.76	6.6 lb

SVA-HS

SVA 15 - 20	mm	63	188	184	202	198	20	120	60	38	60	2.0 kg
SVA (½ - ¾)	in.	2.48	7.40	7.24	7.95	7.80	0.79	4.72	2.36	1.50	2.36	4.4 lb
SVA 25 - 40	mm	74	243	252	256	265	26	155	80	50	70	3.0 kg
SVA (1 - 1½)	in.	2.91	9.57	9.92	10.08	10.43	1.02	6.10	3.15	1.97	2.76	6.6 lb

SVA-HS, Socket weld

SVA 32	mm	74	244	253	256	265	27.4	155	80	50	70	3.0 kg
SVA (1¼)	in.	2.91	9.61	9.96	10.08	10.43	1.08	6.10	3.15	1.97	2.76	6.6 lb
SVA 40	mm	74	248	257	256	265	31.0	155	80	50	70	3.0 kg
SVA (1½)	in.	2.91	9.76	10.12	10.08	10.43	1.22	6.10	3.15	1.97	2.76	6.6 lb

Specified weights are approximate values only.

Dimensions and weights

SVA 50 - 65 (2 - 2½ in.) in angleway version with cap / hand wheel

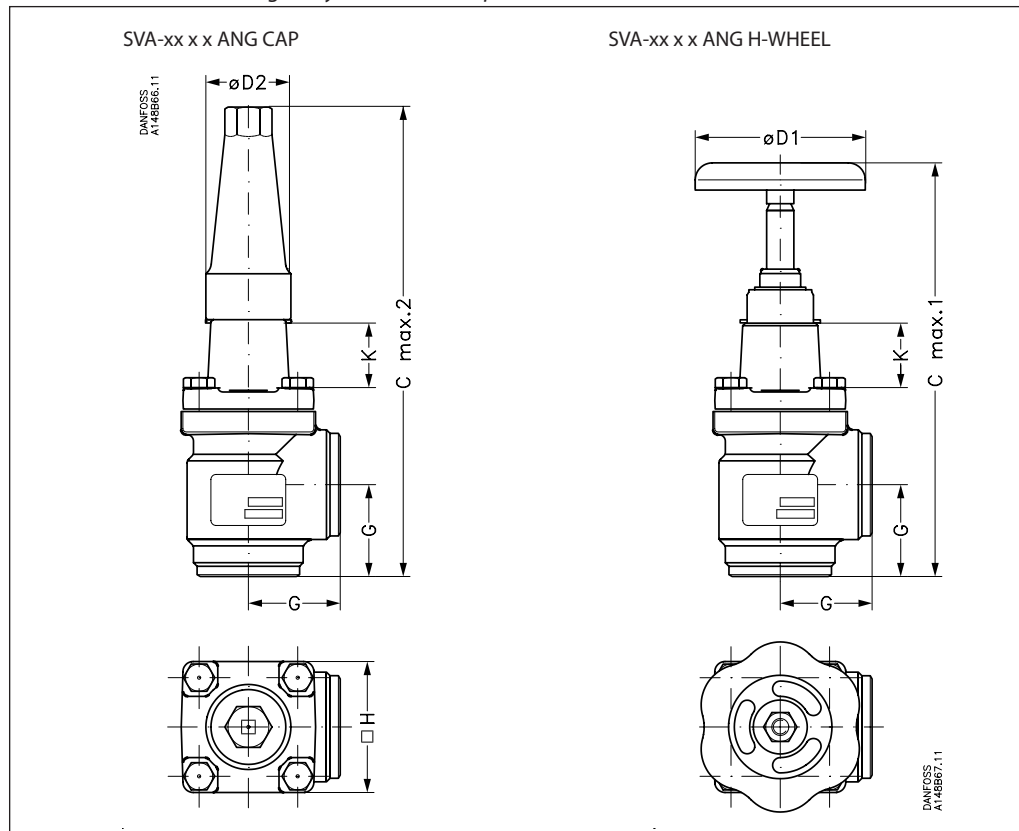

Valve size		K	C _{max.1}	C _{max.2}	G	ØD ₁	ØD ₂	□H	Weight
------------	--	---	--------------------	--------------------	---	-----------------	-----------------	----	--------

SVA-ST, SS

SVA 50	mm	35	249	280	60	100	50	77	3.2 kg
SVA (2)	in.	1.38	9.80	11.02	2.36	3.94	1.97	3.03	7.1 lb
SVA 65	mm	40	280	305	70	100	50	90	4.8 kg
SVA (2½)	in.	1.57	11.02	12.01	2.76	3.94	1.97	3.54	10.6 lb

SVA-ST, Socket weld

SVA 50	mm	35	254	285	65	100	50	77	4.1 kg
SVA (2)	in.	1.38	10.00	11.22	2.56	3.94	1.97	3.03	9.0 lb

SVA-HS

SVA 50	mm	70	284	315	60	100	50	77	3.2 kg
SVA (2)	in.	2.76	11.18	12.40	2.36	3.94	1.97	3.03	7.1 lb
SVA 65	mm	70	310	335	70	100	50	90	4.8 kg
SVA (2½)	in.	2.76	12.20	13.19	2.76	3.94	1.97	3.54	10.6 lb

SVA-HS, Socket weld

SVA 50	mm	70	289	320	65	100	50	77	4.1 kg
SVA (2)	in.	2.76	11.38	12.60	2.56	3.94	1.97	3.03	9.0 lb

Specified weights are approximate values only.

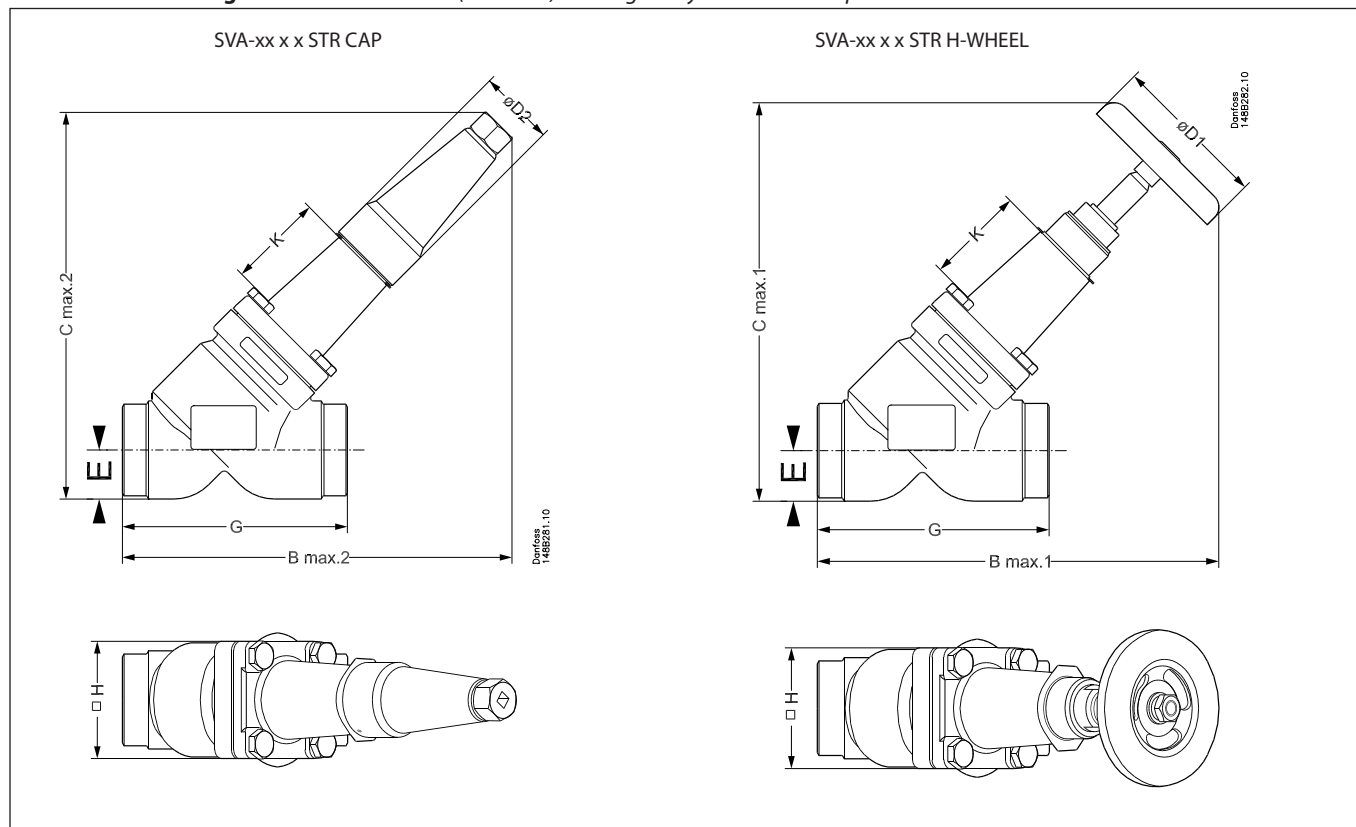
Dimensions and weights SVA 50 - 65 (2 - 2½ in.) in straightway version with cap / hand wheel

Valve size		K	B _{max.1}	B _{max.2}	C _{max.1}	C _{max.2}	E	G	ØD ₁	ØD ₂	□H	Weight
SVA-ST, SS												
SVA 50	mm	35	234	234	232	232	32	148	100	50	77	4.2 kg
SVA (2)	in.	1.38	9.21	9.21	9.13	9.13	1.26	5.83	3.94	1.97	3.03	9.3 lb
SVA 65	mm	40	262	258	262	258	40	176	100	50	90	6.3 kg
SVA (2½)	in.	1.57	10.31	10.16	10.31	10.16	1.57	6.93	3.94	1.97	3.54	13.9 lb
SVA-ST, Socket weld												
SVA 50	mm	35	241	241	236	236	37	162	100	50	77	5.1 kg
SVA (2)	in.	1.38	9.49	9.49	9.29	9.29	1.46	6.38	3.94	1.97	3.03	11.2 lb
SVA-HS												
SVA 50	mm	70	259	259	257	257	32	148	100	50	77	4.2 kg
SVA (2)	in.	2.76	10.20	10.20	10.12	10.12	1.26	5.83	3.94	1.97	3.03	9.3 lb
SVA 65	mm	70	284	280	284	280	40	176	100	50	90	6.3 kg
SVA (2½)	in.	2.76	11.18	11.02	11.18	11.02	1.57	6.93	3.94	1.97	3.54	13.9 lb
SVA-HS, Socket weld												
SVA 50	mm	70	266	266	261	261	37	62	100	50	77	5.1 kg
SVA (2)	in.	2.76	10.47	10.47	10.28	10.28	1.26	6.38	3.94	1.97	3.03	11.2 lb

Specified weights are approximate values only.

Dimensions and weights

SVA 80 - 200 (3 - 8 in.) angleway version with cap / hand wheel

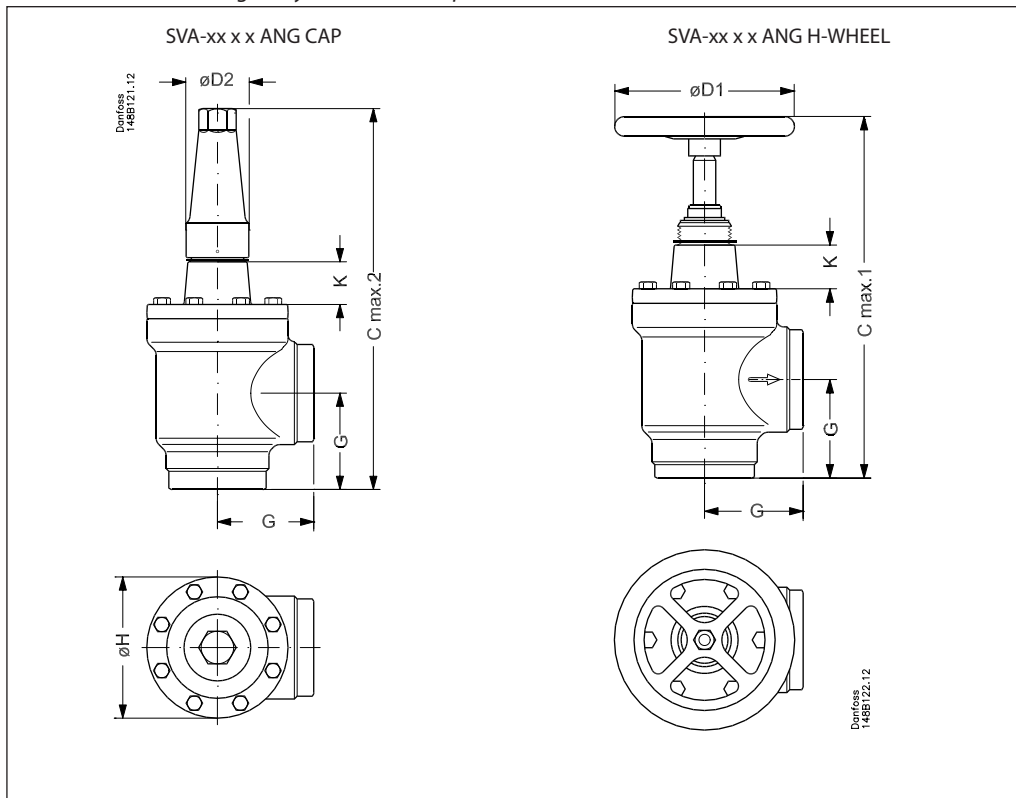

Valve size	K	C _{max.1}	C _{max.2}	G	ØD ₁	ØD ₂	ØH	Weight
------------	---	--------------------	--------------------	---	-----------------	-----------------	----	--------

SVA-ST, SS

SVA 80	mm	41	338	353	90	200	58	129	9.2 kg
SVA (3)	in.	1.61	13.31	13.90	3.54	7.87	2.28	5.08	20.3 lb
SVA 100	mm	43	382	388	106	250	58	156	14.8 kg
SVA (4)	in.	1.69	15.04	15.28	4.17	9.84	2.28	6.14	32.6 lb
SVA 125	mm	90	517	533	128	315	74	193	28.1 kg
SVA (5)	in.	3.54	20.35	20.98	5.04	12.40	2.91	7.60	61.9 lb
SVA 150	mm	90	564	568	145	315	74	219	39.7 kg
SVA (6)	in.	3.54	22.20	22.36	5.71	12.40	2.91	8.62	87.5 lb
SVA 200	mm	90	675	678	180	400	86	276	79.5 kg
SVA (8)	in.	3.54	26.57	26.69	7.09	15.75	3.39	10.87	175.3 lb

SVA-HS

SVA 80	mm	76	373	388	90	200	58	129	9.7 kg
SVA (3)	in.	3.00	14.69	15.28	3.54	7.87	2.28	5.08	21.4 lb
SVA 100	mm	90	432	437	106	250	58	156	15.3 kg
SVA (4)	in.	3.54	17.00	17.20	4.17	9.84	2.28	6.14	33.7 lb
SVA 125	mm	90	517	533	128	315	74	193	28.1 kg
SVA (5)	in.	3.54	20.35	20.98	5.04	12.40	2.91	7.60	61.9 lb
SVA 150	mm	90	564	568	145	315	74	219	39.7 kg
SVA (6)	in.	3.54	22.20	22.36	5.71	12.40	2.91	8.62	87.5 lb
SVA 200	mm	90	675	678	180	400	86	276	79.5 kg
SVA (8)	in.	3.54	26.57	26.69	7.09	15.75	3.39	10.87	175.3 lb

Specified weights are approximate values only.

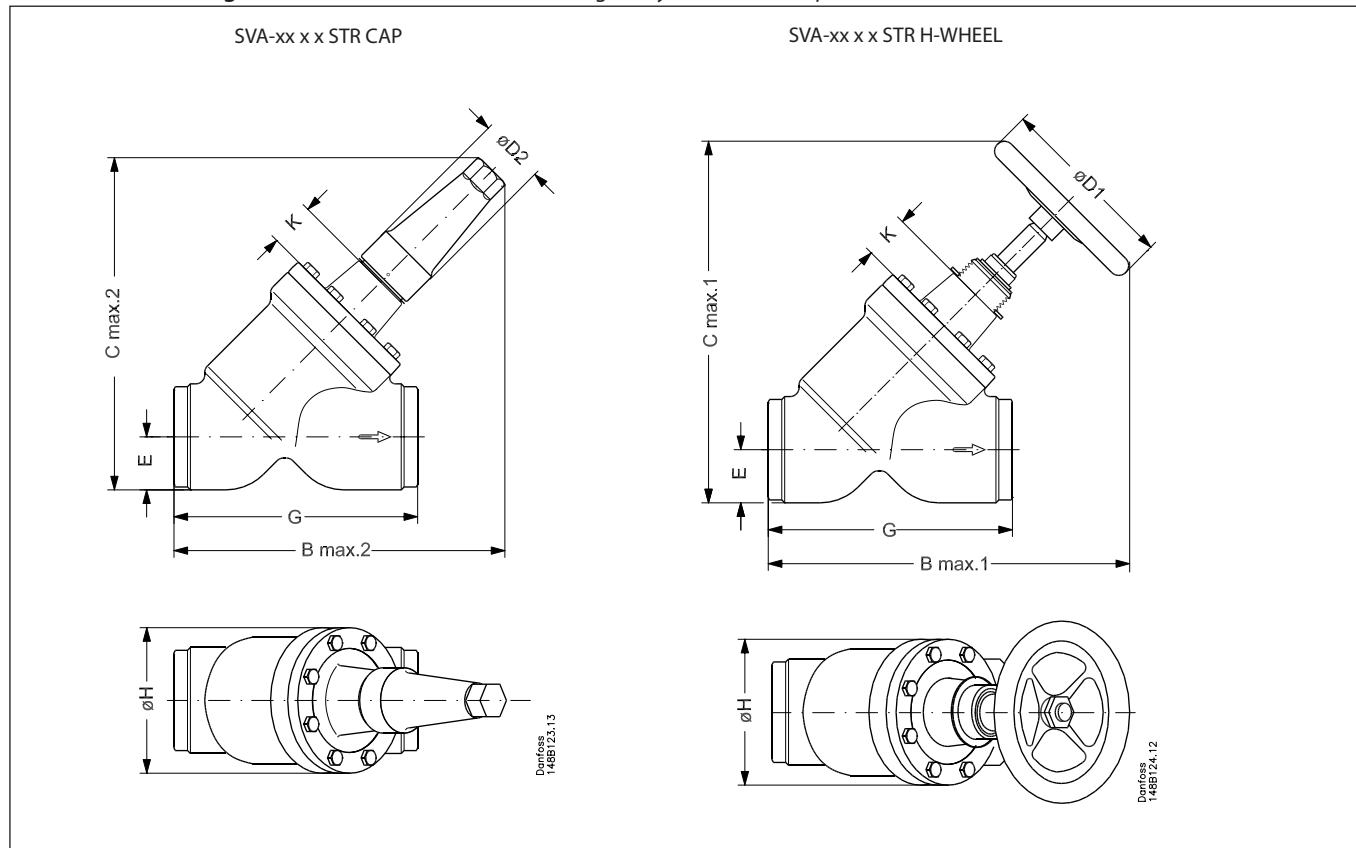
Dimensions and weights SVA 80 - 200 (3 - 8 in.) straightway version with cap / hand wheel

Valve size		K	B _{max.1}	B _{max.2}	C _{max.1}	C _{max.2}	E	G	ØD ₁	ØD ₂	ØH	Weight
SVA-ST												
SVA 80	mm	41	340	296	342	298	48	216	200	58	129	10.4 kg
SVA (3)	in.	1.61	13.38	11.65	13.46	11.73	1.89	8.50	7.87	2.28	5.08	22.9 lb
SVA 100	mm	43	400	331	408	339	60	264	250	58	156	17.7 kg
SVA (4)	in.	1.69	15.75	13.03	16.06	13.35	2.36	10.39	9.84	2.28	6.14	39.0 lb
SVA 125	mm	90	526	444	538	456	74	322	315	74	193	32.8 kg
SVA (5)	in.	3.54	20.71	17.48	21.18	17.95	2.91	12.68	12.40	2.91	7.60	72.3 lb
SVA 150	mm	90	572	483	594	505	91	370	315	74	219	60.0 kg
SVA (6)	in.	3.54	22.52	19.02	23.39	19.88	3.58	14.57	12.40	2.91	8.62	132.3 lb
SVA 200	mm	90	692	579	726	613	117	464	400	86	276	111.5 kg
SVA (8)	in.	3.54	27.24	22.80	28.58	24.13	4.61	18.27	15.75	3.39	10.87	245.8 lb
SVA-HS												
SVA 80	mm	76	365	321	367	232	48	216	200	58	129	10.9 kg
SVA (3)	in.	3.00	14.37	12.64	14.45	12.72	1.89	8.50	7.87	2.28	5.08	24.0 lb
SVA 100	mm	90	435	367	443	375	60	264	250	58	156	18.2 kg
SVA (4)	in.	3.54	17.13	14.45	17.44	14.76	2.36	10.39	9.84	2.28	6.14	40.1 lb
SVA 125	mm	90	526	444	538	456	74	322	315	74	193	32.8 kg
SVA (5)	in.	3.54	20.71	17.48	21.18	17.95	2.91	12.68	12.40	2.91	7.60	72.3 lb
SVA 150	mm	90	572	483	594	505	91	370	315	74	219	60.0 kg
SVA (6)	in.	3.54	22.52	19.02	23.39	19.88	3.58	14.57	12.40	2.91	8.62	132.3 lb
SVA 200	mm	90	692	579	726	613	117	464	400	86	276	111.5 kg
SVA (8)	in.	3.54	27.24	22.80	28.58	24.13	4.61	18.27	15.75	3.39	10.87	245.8 lb

Specified weights are approximate values only.

Ordering

Please note that the type codes only serve to identify the valves, some of which may not form part of the standard product range. For further information please contact your local Danfoss Sales Company.

Type codes

Valve type	SVA	Stop valve	Available connections				
			A/D	SOC	FPT	T	
Nominal size in mm (valve size measured on the connection diameter)	6	DN 6 (1/4)	x			x	
	10	DN 10 (3/8)	x			x	
	15	DN 15 (1/2)	x	x	x		
	20	DN 20 (3/4)	x	x	x		
	25	DN 25 (1)	x	x	x		
	32	DN 32 (1 1/4)	x	x	x		
	40	DN 40 (1 1/2)	x	x			
	50	DN 50 (2)	x	x			
	65	DN 65 (2 1/2)	x				
	80	DN 80 (3)	x				
	100	DN 100 (4)	x				
	125	DN 125 (5)	x				
	150	DN 150 (6)	x				
	200	DN 200 (8)	x				
	Connections	A D SOC FPT T	Butt-weld connection: ANSI B 36.10 schedule 80, DN 15 - 40 (1/2 - 1 1/2 in.) Butt-weld connection: ANSI B 36.10 schedule 40, DN 50 - 200 (2 - 8 in.) Butt-weld connection: DIN 2448 Socket weld: ANSI B 16.11 Female Pipe Thread NPT: ANSI/ASME B 1.20.1 Outside threaded connections ISO 228/1 Pipe thread				
	Valve housing	ANG STR	Angle flow Straight flow				
Other equipment	H-WHEEL CAP	Hand wheel Cap					

Important!

Where products need to be certified according to specific certification societies or where higher pressures are required, the relevant information should be included at the time of order.

Ordering
(cont.)

Example:
SVA 6 ANSI angleway with cap =
2412+336

Important!

Where products need to be certified according to specific certification societies or where higher pressures are required, the relevant information should be included at the time of order.

D = Butt-weld DIN
A = Butt-weld ANSI

The table below is used to identify the valve required.

Size		Type	Code number
mm	in.		

DIN

6	1/4	SVA 6 D ANG H-WHEEL	2412+308
6	1/4	SVA 6 D ANG CAP	2412+315
10	3/8	SVA 10 D ANG H-WHEEL	2412+309
10	3/8	SVA 10 D ANG CAP	2412+316

ANSI

6	1/4	SVA 6 A ANG H-WHEEL	2412+350
6	1/4	SVA 6 A ANG CAP	2412+357
10	3/8	SVA 10 A ANG H-WHEEL	2412+351
10	3/8	SVA 10 A ANG CAP	2412+358

Size		Type	Code number
mm	in.		

DIN

6	1/4	SVA 6 D STR H-WHEEL	2412+329
6	1/4	SVA 6 D STR CAP	2412+336
10	3/8	SVA 10 D STR H-WHEEL	2412+330
10	3/8	SVA 10 D STR CAP	2412+337

ANSI

6	1/4	SVA 6 A STR H-WHEEL	2412+371
6	1/4	SVA 6 A STR CAP	2412+378
10	3/8	SVA 10 A STR H-WHEEL	2412+372
10	3/8	SVA 10 A STR CAP	2412+379

SVA 6T and SVA-ST 10-15 T

Type	Code number
SVA-ST 10-15 T STOPVALVE STR H-WHEEL	148B3969
SVA-ST 10-15 T STOPVALVE STR CAP	148B3970
SVA-ST 10-15 T STOPVALVE ANG H-WHEEL	148B3818
SVA-ST 10-15 T STOPVALVE ANG CAP	148B3819
SVA-ST 6 T STOPVALVE ANG H-WHEEL	2413+123
SVA-ST 6 T STOPVALVE ANG CAP	2413+125

Accessories
6T and 10-15T Nipple Kit solution

Code no.	
148B4244	ACCESSORY WELD.NIPPLE DN10 D + UNION NUT
148B4245	ACCESSORY WELD.NIPPLE DN6 A + UNION NUT
148B4246	ACCESSORY WELD.NIPPLE DN10 A + UNION NUT
148B4247	ACCESSORY WELD.NIPPLE DN15 A + UNION NUT
148B4184	ACCESSORY WELD.NIPPLE DN6 D + UNION NUT
148B4185	ACCESSORY WELD.NIPPLE DN15 D + UNION NUT

DN6 nipples are used with SVA 6 T.
DN10 and DN15 nipples are used with SVA-ST 10-15 T.

Lock washers for the stop valves, subjected to extreme vibrations/pulsations

Code no.	
148B4238	I-PACK(10) ACC.LOCK WASHER SVA 15-20
148B4239	I-PACK(10) ACC.LOCK WASHER SVA 25-40
148B4240	I-PACK(10) ACC.LOCK WASHER SVA 50-65
148B4241	I-PACK(10) ACC.LOCK WASHER SVA 80-100
148B4242	I-PACK(10) ACC.LOCK WASHER SVA 125-150
148B4243	I-PACK(10) ACC.LOCK WASHER SVA 200

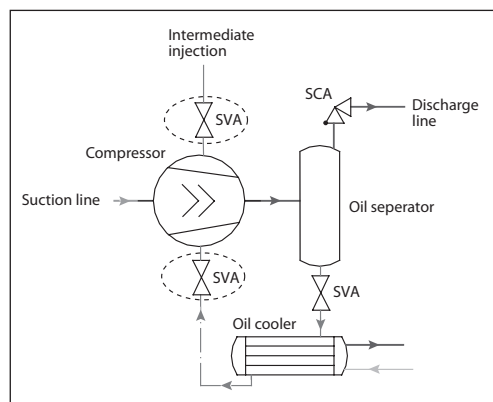

Indication of a pipe line, where stop valves with lock washers are recommended.

Technical leaflet

Stop valves for industrial refrigeration, type SVA, SVA-ST, SVA-HS and SVA-SS

Ordering - SVA-ST (cont.)

Example: SVA-ST 20 DIN angleyway with hand wheel = 148B3441

Important!

Where products need to be certified according to specific certification societies or where higher pressures are required, the relevant information should be included at the time of order.

The table below is used to identify the valve required.

Standard version Angleyway table with columns: Size (mm, in.), Type, MWP (bar, psi), Code number

Standard version Straightway table with columns: Size (mm, in.), Type, MWP (bar, psi), Code number

DIN table listing valve specifications for sizes 15 to 200, including type (e.g., 15 D ANG H-WHEEL), MWP, and code numbers.

DIN table listing valve specifications for sizes 15 to 200, including type (e.g., 15 D STR H-WHEEL), MWP, and code numbers.

ANSI table listing valve specifications for sizes 15 to 200, including type (e.g., 15 A ANG H-WHEEL), MWP, and code numbers.

ANSI table listing valve specifications for sizes 15 to 200, including type (e.g., 15 STR H-WHEEL), MWP, and code numbers.

SOC table listing valve specifications for sizes 15 to 50, including type (e.g., 15 SOC ANG H-WHEEL), MWP, and code numbers.

SOC table listing valve specifications for sizes 15 to 50, including type (e.g., 15 SOC STR H-WHEEL), MWP, and code numbers.

FPT table listing valve specifications for sizes 15 to 32, including type (e.g., 15 FPT ANG H-WHEEL), MWP, and code numbers.

FPT table listing valve specifications for sizes 15 to 32, including type (e.g., 15 FPT STR H-WHEEL), MWP, and code numbers.

D = Butt-weld DIN
A = Butt-weld ANSI
SOC = Socket welding
FPT = Inside pipe thread

ANG = Angle-way
STR = Straight-way

CAP = Cap
H-WHEEL = Hand wheel

Ordering SVA-ST (high pressure)
(continued)

Important!

Where products need to be certified according to specific certification societies or where higher pressures are required, the relevant information should be included at the time of order.

The table below is used to identify the valve required.

Standard version (high pressure)					
Angleway					
Size		Type	MWP		Code number
mm	in.		bar	psi	

DIN

10	3/8	SVA-ST 10 D ANG STOP VALVE CAP 52BAR	52	754	148B3829
10	3/8	SVA-ST 10 D ANG STOP VALVE H-WHEEL 52BAR	52	754	148B3830
15	1/2	SVA-ST 15 D ANG STOP VALVE CAP 52BAR	52	754	148B3831
15	1/2	SVA-ST 15 D ANG STOP VALVE H-WHEEL 52BAR	52	754	148B3832
20	3/4	SVA-ST 20 D ANG STOP VALVE CAP 52BAR	52	754	148B3815
20	3/4	SVA-ST 20 D ANG STOP VALVE H-WHEEL 52BAR	52	754	148B3833
25	1	SVA-ST 25 D ANG STOP VALVE CAP 52BAR	52	754	148B3834
25	1	SVA-ST 25 D ANG STOP VALVE H-WHEEL 52BAR	52	754	148B3835
32	1 1/4	SVA-ST 32 D ANG STOP VALVE CAP 52BAR	52	754	148B3836
32	1 1/4	SVA-ST 32 D ANG STOP VALVE H-WHEEL 52BAR	52	754	148B3837
40	1 1/2	SVA-ST 40 D ANG STOP VALVE CAP 52BAR	52	754	148B3838
40	1 1/2	SVA-ST 40 D ANG STOP VALVE H-WHEEL 52BAR	52	754	148B3839
50	2	SVA-ST 50 D ANG STOP VALVE CAP 52BAR	52	754	148B3840
50	2	SVA-ST 50 D ANG STOP VALVE H-WHEEL 52BAR	52	754	148B3841
65	2 1/2	SVA-ST 65 D ANG STOP VALVE CAP 52BAR	52	754	148B3791
65	2 1/2	SVA-ST 65 D ANG STOP VALVE H-WHEEL 52BAR	52	754	148B3842
80	3	SVA-ST 80 D ANG STOP VALVE CAP 50BAR	50	725	148B4293
100	4	SVA-ST100 D ANG STOP VALVE CAP 50BAR	50	725	148B3779
125	5	SVA-ST125 D ANG STOP VALVE CAP 50BAR	50	725	148B3995
150	6	SVA-ST150 D ANG STOP VALVE CAP 50BAR	50	725	148B4294
200	8	SVA-ST200 D ANG STOP VALVE CAP 50BAR	50	725	148B3998

Standard version (high pressure)					
Straightway					
Size		Type	MWP		Code number
mm	in.		bar	psi	

DIN

10	3/8	SVA-ST 10 D STR STOP VALVE CAP 52BAR	52	754	148B3859
15	1/2	SVA-ST 15 D STR STOP VALVE CAP 52BAR	52	754	148B3862
20	3/4	SVA-ST 20 D STR STOP VALVE CAP 52BAR	52	754	148B3897
25	1	SVA-ST 25 D STR STOP VALVE CAP 52BAR	52	754	148B3898
32	1 1/4	SVA-ST 32 D STR STOP VALVE CAP 52BAR	52	754	148B3899
40	1 1/2	SVA-ST 40 D STR STOP VALVE CAP 52BAR	52	754	148B3991
50	2	SVA-ST 50 D STR STOP VALVE CAP 52BAR	52	754	148B3992
65	2 1/2	SVA-ST 65 D STR STOP VALVE CAP 52BAR	52	754	148B3993
80	3	SVA-ST 80 D STR STOP VALVE CAP 50BAR	50	725	148B4248
100	4	SVA-ST100 D STR STOP VALVE CAP 50BAR	50	725	148B3994
125	5	SVA-ST125 D STR STOP VALVE CAP 50BAR	50	725	148B3996
150	6	SVA-ST150 D STR STOP VALVE CAP 50BAR	50	725	148B3997
200	8	SVA-ST200 D STR STOP VALVE CAP 50BAR	50	725	148B4295

D = Butt-weld DIN

ANG = Angle-way

STR = Straight-way

CAP = Cap

H-WHEEL = Hand wheel

Ordering - SVA-SS

Example:
SVA-SS 32 DIN angleway with hand wheel = **148B3850**

Important!

Where products need to be certified according to specific certification societies or where higher pressures are required, the relevant information should be included at the time of order.

The table below is used to identify the valve required.

Stainless Steel version (high pressure)					
Angleway					
Size		Type	MWP		Code number
mm	in.		bar	psi	

DIN

15	½	SVA-SS 15 D ANG CAP 52 BAR	52	754	148B3843
15	½	SVA-SS 15 D ANG H-WHEEL 52 BAR	52	754	148B3844
20	¾	SVA-SS 20 D ANG CAP 52 BAR	52	754	148B3845
20	¾	SVA-SS 20 D ANG H-WHEEL 52 BAR	52	754	148B3846
25	1	SVA-SS 25 D ANG CAP 52 BAR	52	754	148B3847
25	1	SVA-SS 25 D ANG H-WHEEL 52 BAR	52	754	148B3848
32	1¼	SVA-SS 32 D ANG CAP 52 BAR	52	754	148B3849
32	1¼	SVA-SS 32 D ANG H-WHEEL 52 BAR	52	754	148B3850
40	1½	SVA-SS 40 D ANG CAP 52 BAR	52	754	148B3851
40	1½	SVA-SS 40 D ANG H-WHEEL 52 BAR	52	754	148B3852
50	2	SVA-SS 50 D ANG CAP 52 BAR	52	754	148B3853
50	2	SVA-SS 50 D ANG H-WHEEL 52 BAR	52	754	148B3854
65	2½	SVA-SS 65 D ANG CAP 52 BAR	52	754	148B3855
65	2½	SVA-SS 65 D ANG H-WHEEL 52 BAR	52	754	148B3856
80	3	SVA-SS 80 D ANG CAP 50 BAR	50	725	148B4451
100	4	SVA-SS 100 D ANG CAP 50 BAR	50	725	148B4452
125	5	SVA-SS 125 D ANG CAP 50 BAR	50	725	148B4453

Stainless Steel version (high pressure)					
Straightway					
Size		Type	MWP		Code number
mm	in.		bar	psi	

DIN

15	½	SVA-SS 15 D STR CAP 52 BAR	52	754	148B4249
15	½	SVA-SS 15 D STR H-WHEEL 52 BAR	52	754	148B4250
20	¾	SVA-SS 20 D STR CAP 52 BAR	52	754	148B4251
20	¾	SVA-SS 20 D STR H-WHEEL 52 BAR	52	754	148B4252
25	1	SVA-SS 25 D STR CAP 52 BAR	52	754	148B4253
25	1	SVA-SS 25 D STR H-WHEEL 52 BAR	52	754	148B4254
32	1¼	SVA-SS 32 D STR CAP 52 BAR	52	754	148B4255
32	1¼	SVA-SS 32 D STR H-WHEEL 52 BAR	52	754	148B4256
40	1½	SVA-SS 40 D STR CAP 52 BAR	52	754	148B4257
40	1½	SVA-SS 40 D STR H-WHEEL 52 BAR	52	754	148B4258
50	2	SVA-SS 50 D STR CAP 52 BAR	52	754	148B4259
50	2	SVA-SS 50 D STR H-WHEEL 52 BAR	52	754	148B4260
65	2½	SVA-SS 65 D STR CAP 52 BAR	52	754	148B4261
65	2½	SVA-SS 65 D STR H-WHEEL 52 BAR	52	754	148B4262

D = Butt-weld DIN

ANG = Angle-way

STR = Straight-way

CAP = Cap

H-WHEEL = Hand wheel

