

Data sheet

Thermostatic expansion valves

Type T2 / TE2



Thermostatic expansion valves regulate the injection of refrigerant liquid into evaporators.

Injection is controlled by the refrigerant superheat.

Therefore the valves are especially suitable for liquid injection in "dry" evaporators where the superheat at the evaporator outlet is proportional to the evaporator load.

Features

- Large temperature range
 - Equally applicable to freezing, refrigeration and air conditioning applications.
- Interchangeable orifice assembly
 - easy storage
 - easy capacity matching
 - better service.
 - easy cleaning and replacement of filter
- Rated capacities from 1 to 20.5 kW / 0.3 to 5.8 TR for R407C
- Can be supplied with MOP (Max. Operating Pressure).
 - Protects the compressor motor against excessive evaporating pressure during normal operation
- Stainless steel bulb and Danfoss patented bulb strap
 - Fast and easy to install
 - Good temperature transfer from pipe to bulb
- Valves for special temperature ranges can be supplied
- Design protected

Identification

The thermostatic element has laser engraved data on top of the diaphragm. This engraving gives valve type (with code number), evaporating temperature range, MOP point, refrigerant, and max. working pressure. PS/MWP.

T2 = internal equalization
TE2 = external equalization

Production place and date
N4511A =
N = Nordborg, Denmark
(BE = Wuqing, China)
45 = week
11 = 2011
A = Monday

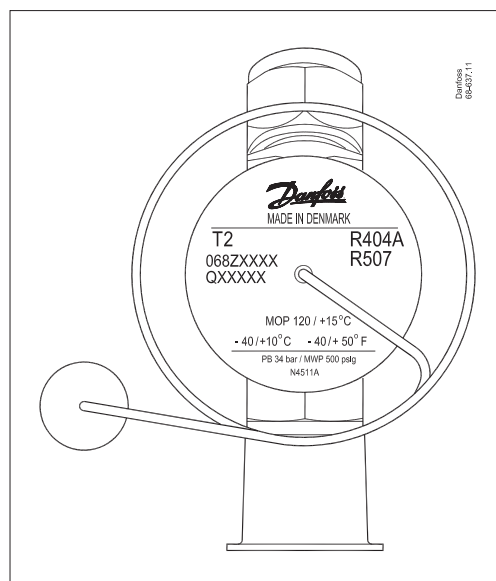

Orifice assembly for T2 and TE2

The orifice assembly is marked with the orifice size (e.g. 06) and week stamp + last number in the year (e.g. 174).
The orifice assembly number is also given on the lid of its plastic container.

Orifice assembly and filter for flare x flare version for T2 and TE2

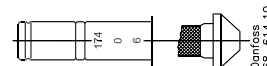

Capillary tube label for T2 and TE2

The label gives the orifice size (04) and consists of the lid of the orifice assembly plastic container. It can easily be fastened around the expansion valve capillary tube to clearly identify the valve size.

Capillary tube label T2 and TE2



Technical data

Max. temperature
Bulb, when valve is installed: 100 °C
Bulb, element not mounted: 60 °C

Max. test pressure
PT = 38 bar

Min. temperature
T2 – TE2: -60 °C

Max. working pressure
PS/MWP = 34 bar

MOP-points

Refrigerant	Range N	Range NM	Range NL	Range B
	-40 °C – 10 °C	-40 °C – -5 °C	-40 °C – -15 °C	-60 °C – -25 °C
	MOP-point in evaporating temperature t_e and evaporating pressure p_e ¹⁾			
	15 °C / 60 °F	0 °C / 32 °F	-10 °C / 15 °F	-20 °C / -4 °F
R22	100 psig / 6.9 bar (abs)	60 psig / 4.0 bar (abs)	35 psig / 2.4 bar (abs)	20 psig / 1.4 bar (abs)
R407C	95 psig / 6.6 bar (abs)	–	–	–
R134a	55 psig / 3.8 bar (abs)	30 psig / 2.0 bar (abs)	15 psig / 1.0 bar (abs)	–
R404A/R507	120 psig / 8.3 bar (abs)	75 psig / 5.2 bar (abs)	50 psig / 3.4 bar (abs)	30 psig / 2.1 bar (abs)

¹⁾ Pe in bar gauge

Superheat

SS = static superheat
OS = opening superheat
SH = SS + OS = total superheat
 Q_{nom} = rated capacity
 Q_{max} = maximum capacity

Standard superheat setting SS is 4K for all standard valves.
The opening superheat OS is 6 K from when opening begins to where the valve gives its rated capacity Q_{nom} .

Static superheat SS can be adjusted with setting spindle.

Example
Static superheat SS = 5 K
Opening superheat OS = 6 K
Total superheat SH = 5 + 6 = 11 K

Design Function

General

T2 and TE2 valves have an interchangeable orifice assembly.

The orifice assembly is suitable for all versions of valve body and refrigerants and in all evaporating temperature ranges.

The charge in the thermostatic element depends on the refrigerant and evaporating temperature range.

The valves are available with internal (T2) or external (TE2) pressure equalization.

External pressure equalization should always be used on systems with liquid distributors.

The bulb gives fast and precise reaction to temperature changes in the evaporator. The bulb is fixed with a Danfoss patented bulb strap for quick, easy and reliable connection. The valves are able to withstand the effects that normally occur with hot gas defrosting.

To ensure long operating life, the valve cone and seat are made of a special alloy with particularly good wear qualities.

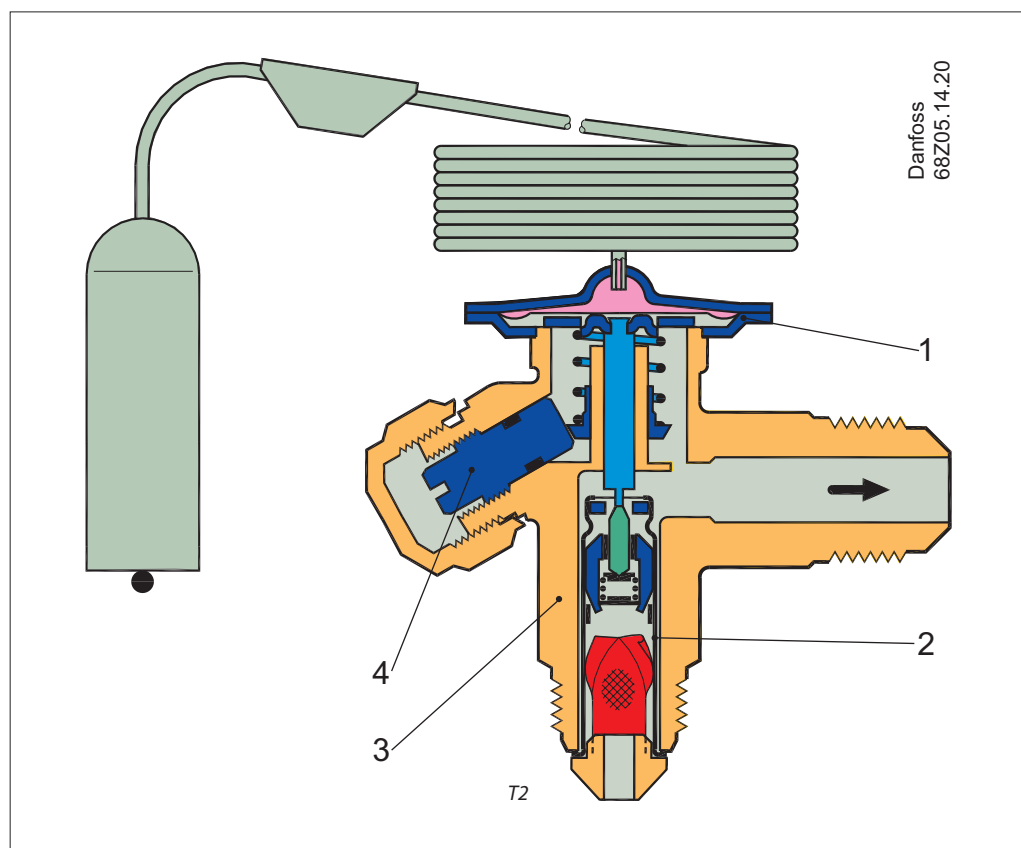

- 1. Thermostatic element (diaphragm)
- 2. Interchangeable orifice assembly
- 3. Valve body
- 4. Superheat setting spindle (see instructions)

Technical data and ordering

 T2/TE2 Thermostatic element with bulb strap
 Flare x flare

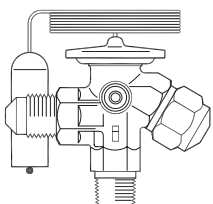
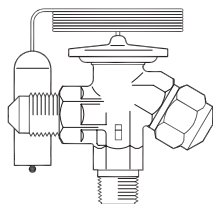
 Capillary tube: 1.5 m
 Range N = -40 – 10 °C
 Range B = -60 – -25 °C
 Range NM = -40 – -5 °C MOP 0 °C
 Range NL = -40 – -15 °C MOP -10 °C

Refrigerant	Type	Range	MOP	Pressure equalization Flare	Connection flare inlet x outlet		Code no. Multi pack
		[°C]	[°C]		[in.]	[mm]	
R22/R407C ¹⁾	T2	-40 – 10	–	–	3/8 x 1/2	10x12	068Z3206
	T2	-40 – 10	15	–	3/8 x 1/2	10x12	068Z3208
	T2	-40 – -5	0	–	3/8 x 1/2	10x12	068Z3224
	T2	-40 – -15	-10	–	3/8 x 1/2	10x12	068Z3226
	T2	-60 – -25	–	–	3/8 x 1/2	10x12	068Z3207
	T2	-60 – -25	-20	–	3/8 x 1/2	10x12	068Z3228
	TE2	-40 – 10	–	1/4 in / 6mm	3/8 x 1/2	10x12	068Z3209
	TE2	-40 – 10	15	1/4 in / 6mm	3/8 x 1/2	10x12	068Z3211
	TE2	-40 – -5	0	1/4 in / 6mm	3/8 x 1/2	10x12	068Z3225
	TE2	-40 – -15	-10	1/4 in / 6mm	3/8 x 1/2	10x12	068Z3227
R407C	T2	-40 – 10	–	–	3/8 x 1/2	10x12	068Z3496
	T2	-40 – 10	15	–	3/8 x 1/2	10x12	068Z3516
	TE2	-40 – 10	–	1/4 in / 6mm	3/8 x 1/2	10x12	068Z3501
	TE2	-40 – 10	15	1/4 in / 6mm	3/8 x 1/2	10x12	068Z3517
R134a/R513A	T2	-40 – 10	–	–	3/8 x 1/2	10x12	068Z3346
	T2	-40 – 10	15	–	3/8 x 1/2	10x12	068Z3347
	T2	-40 – -5	0	–	3/8 x 1/2	10x12	068Z3393
	T2	-40 – -15	-10	–	3/8 x 1/2	10x12	068Z3369
	TE2	-40 – 10	–	1/4 in / 6mm	3/8 x 1/2	10x12	068Z3348
	TE2	-40 – 10	15	1/4 in / 6mm	3/8 x 1/2	10x12	068Z3349
	TE2	-40 – -5	0	1/4 in / 6mm	3/8 x 1/2	10x12	068Z3392
R404A/R507	TE2	-40 – -15	-10	–	3/8 x 1/2	10x12	068Z3370
	T2	-40 – 10	–	–	3/8 x 1/2	10x12	068Z3400
	T2	-40 – 10	15	–	3/8 x 1/2	10x12	068Z3402
	T2	-40 – -5	0	–	3/8 x 1/2	10x12	068Z3406
	T2	-40 – -15	-10	–	3/8 x 1/2	10x12	068Z3408
	T2	-60 – -25	–	–	3/8 x 1/2	10x12	068Z3401
	T2	-60 – -25	-20	–	3/8 x 1/2	10x12	068Z3410
	TE2	-40 – 10	–	1/4 in / 6mm	3/8 x 1/2	10x12	068Z3403
	TE2	-40 – 10	15	1/4 in / 6mm	3/8 x 1/2	10x12	068Z3405
	TE2	-40 – -5	0	1/4 in / 6mm	3/8 x 1/2	10x12	068Z3407
	TE2	-40 – -15	-10	1/4 in / 6mm	3/8 x 1/2	10x12	068Z3409
	TE2	-60 – -25	–	1/4 in / 6mm	3/8 x 1/2	10x12	068Z3404
R407F/R407A	TE2	-60 – -25	-20	1/4 in / 6mm	3/8 x 1/2	10x12	068Z3411
	T2	-40 – 10	–	–	3/8 x 1/2	10x12	068Z3715
R448A/R449A	TE2	-40 – 10	–	1/4 in / 6mm	3/8 x 1/2	10x12	068Z3714
	T2	-40 – 10	–	–	3/8 x 1/2	–	068Z3727
	TE2	-40 – 10	–	1/4 in / 6mm	3/8 x 1/2	10x12	068Z3728
	T2	-40 – -15	-10	–	3/8 x 1/2	10x12	068Z3675
	T2	-60 – -25	-20	–	3/8 x 1/2	10x12	068Z3735
TE2	-60 – -25	-20	1/4 in / 6mm	3/8 x 1/2	10x12	068Z3736	

¹⁾ For R407C plants. Please select valves from the dedicated R407C program

Technical data and ordering
T2/TE2 Thermostatic element with bulb strap
 Flare x solder

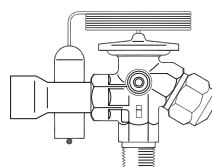
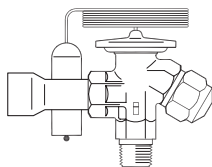
 Capillary tube: 1.5 m
 Range N = -40 – 10 °C
 Range NL = -40 – -15 °C
 Range B = -60 – -25 °C

Refrigerant	Type	Range	MOP	Pressure equalization solder	Connection		Code no. Multi pack
		[°C]	[°C]		inlet (Flare) × outlet (Solder)	[in.] [mm]	
R22/R407C ¹⁾	T2	-40 – 10	–	–	3/8 × 1/2	–	068Z3281
	T2	-40 – 10	–	–	–	10×12	068Z3302
	T2	-40 – 10	15	–	3/8 × 1/2	–	068Z3287
	T2	-40 – 10	15	–	–	10×12	068Z3308
	T2	-40 – -15	-10	–	–	10×12	068Z3366
	T2	-60 – -25	–	–	3/8 × 1/2	–	068Z3357
	T2	-60 – -25	–	–	–	10×12	068Z3361
	T2	-60 – -25	-20	–	3/8 × 1/2	–	068Z3319
	TE2	-40 – 10	–	1/4 in.	3/8 × 1/2	–	068Z3284
	TE2	-40 – 10	–	6 mm	–	10×12	068Z3305
	TE2	-40 – 10	15	1/4 in.	3/8 × 1/2	–	068Z3290
	TE2	-40 – 10	15	6 mm	–	10×12	068Z3311
	TE2	-40 – -15	-10	6 mm	–	10×12	068Z3367
	TE2	-60 – -25	–	1/4 in.	3/8 × 1/2	–	068Z3359
R407C	TE2	-60 – -25	–	6 mm	–	10×12	068Z3363
	TE2	-60 – -25	-20	–	3/8 × 1/2	–	068Z3320
	T2	-40 – 10	–	–	–	10×12	068Z3502
	T2	-40 – 10	15	–	3/8 × 1/2	–	068Z3329
	T2	-40 – 10	15	–	–	10×12	068Z3514
	TE2	-40 – 10	–	1/4 in.	3/8 × 1/2	1/2 in.	068Z3446
R134a/R513A	TE2	-40 – 10	–	6 mm	–	10×12	068Z3503
	TE2	-40 – 10	15	1/4 in.	3/8 × 1/2	–	068Z3447
	TE2	-40 – 10	15	6 mm	–	10×12	068Z3515
	T2	-40 – 10	–	–	3/8 × 1/2	–	068Z3383
	T2	-40 – 10	–	–	–	10×12	068Z3384
	T2	-40 – 10	15	–	3/8 × 1/2	–	068Z3387
R404A/R507	T2	-40 – 10	15	–	–	10×12	068Z3388
	TE2	-40 – 10	–	1/4 in.	3/8 × 1/2	–	068Z3385
	TE2	-40 – 10	–	6 mm	–	10×12	068Z3386
	TE2	-40 – 10	15	1/4 in.	3/8 × 1/2	–	068Z3389
	TE2	-40 – 10	15	6 mm	–	10×12	068Z3390
	T2	-40 – 10	–	–	3/8 × 1/2	–	068Z3414
R407F/R407A	T2	-40 – 10	–	–	–	10×12	068Z3435
	T2	-40 – 10	15	–	3/8 × 1/2	–	068Z3416
	T2	-40 – 10	15	–	–	10×12	068Z3423
	T2	-40 – -15	-10	–	3/8 × 1/2	–	068Z3429
	T2	-40 – -15	-10	–	–	10×12	068Z3436
	T2	-60 – -25	–	–	3/8 × 1/2	–	068Z3418
	T2	-60 – -25	–	–	–	10×12	068Z3425
	T2	-60 – -25	-20	–	3/8 × 1/2	–	068Z3420
	T2	-60 – -25	-20	–	–	10×12	068Z3427
	TE2	-40 – 10	–	1/4 in.	3/8 × 1/2	–	068Z3415
	TE2	-40 – 10	–	6 mm	–	10×12	068Z3422
	TE2	-40 – 10	15	6 mm	–	10×12	068Z3424
	TE2	-40 – 10	15	1/4 in.	3/8 × 1/2	–	068Z3417
	TE2	-40 – -15	-10	1/4 in.	3/8 × 1/2	–	068Z3430
	TE2	-40 – -15	-10	6 mm	–	10×12	068Z3437
	TE2	-60 – -25	–	1/4 in.	3/8 × 1/2	–	068Z3419
R448A/R449A	TE2	-60 – -25	–	6 mm	–	10×12	068Z3426
	TE2	-60 – -25	-20	1/4 in.	3/8 × 1/2	–	068Z3421
R452A	TE2	-60 – -25	-20	6 mm	–	10×12	068Z3428
	T2	-40 – 10	–	–	3/8 × 1/2	–	068Z3716
R452A	TE2	-40 – 10	–	1/4 in.	3/8 × 1/2	–	068Z3713
	T2	-40 – 10	–	–	3/8 × 1/2	–	068Z3729
	TE2	-40 – 10	–	1/4 in.	3/8 × 1/2	–	068Z3730
	T2	-40 – -15	-10	–	3/8 × 1/2	–	068Z3664
	T2	-60 – -25	-20	–	3/8 × 1/2	–	068Z3737
	TE2	-40 – -15	-10	1/4 in.	3/8 × 1/2	–	068Z3665
	TE2	-60 – -25	-20	1/4 in.	3/8 × 1/2	–	068Z3738
R452A	TE2	-40 – -15	-10	–	–	10×12	068Z3674
	TE2	-60 – -25	-20	6 mm	–	10×12	068Z3672
	T2	-40 – 10	–	–	3/8 × 1/2	–	068Z3806
	TE2	-40 – 10	–	1/4 in.	3/8 × 1/2	–	068Z3807
R452A	T2	-40 – 10	–	–	–	10×12	068Z3808
	TE2	-40 – 10	–	6 mm	–	10×12	068Z3809

¹⁾ For R407C plants, please select valves from the dedicated R407C program

Data sheet | Thermostatic expansion valves, type T2 / TE2

Flare connections

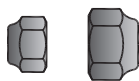

Connection for copper tubing with outside diameter		Reducer for copper tubing with outside diameter		Code no.
[in.]	[mm]	[in.]	[mm]	
1/4	6	–	–	011L1101
3/8	10	–	–	011L1135
1/2	12	–	–	011L1103
–	–	1/4	6	011L1107

Example :

A TE2 thermostatic expansion valve consists of two elements + flare nuts if required:

- 1 thermostatic element
- 1 orifice assembly and flare nuts

When ordering one thermostatic expansion valve, TE2 with orifice 01, five code numbers are required:

- 1-off thermostatic element **068Z3209**
- 1-off orifice assembly 01 **068-2010**
- 1-off 3/8 in. flare nut **011L1135**
- 1-off 1/2 in. flare nut **011L1103**
- 1-off 1/4 in. flare nut **011L1101**

The rated capacity is based on:
 Evaporating temperature $t_e = 40\text{ °F}$
 Condensing temperature $t_c = 100\text{ °F}$
 Refrigerant temperature ahead of valve $t_i = 98\text{ °F}$

Range N: -40 to 50 °F

Orifice no.	Rated capacity in tons (TR)								
	R22	R407C	R134a	R513A	R404A R507	R407A	R407F	R448A	R449A
0X	0.25	0.26	0.19	0.16	0.18	0.25	0.28	0.26	0.25
00	0.51	0.51	0.34	0.29	0.37	0.49	0.56	0.51	0.49
01	1.0	1.0	0.59	0.51	0.75	1.0	1.1	1.0	0.97
02	1.3	1.4	0.73	0.62	1.0	1.3	1.5	1.4	1.3
03	2.3	2.3	1.2	1.0	1.8	2.3	2.6	2.3	2.3
04	3.4	3.5	1.8	1.5	2.8	3.5	4.1	3.6	3.5
05	4.8	4.7	2.4	2.0	3.7	4.6	5.4	4.6	4.5
06	5.6	5.6	2.9	2.5	4.4	5.6	6.5	5.7	5.5

The rated capacity is based on:
 Evaporating temperature $t_e = 4.4\text{ °C}$
 Condensing temperature $t_c = 38\text{ °C}$
 Refrigerant temperature ahead of valve $t_i = 37\text{ °C}$

Range N: -40 to 10 °C

Orifice no.	Rated capacity in kW								
	R22	R407C	R134a	R513A	R404A R507	R407A	R407F	R448A	R449A
0X	0.90	0.92	0.68	0.58	0.64	0.88	1.0	0.90	0.88
00	1.8	1.8	1.2	1.0	1.3	1.7	2.0	1.8	1.7
01	3.5	3.5	2.1	1.8	2.6	3.4	3.9	3.5	3.4
02	4.7	4.8	2.6	2.2	3.7	4.7	5.4	4.8	4.6
03	8.0	8.1	4.3	3.7	6.3	8.0	9.2	8.1	7.9
04	12.1	12.4	6.4	5.4	9.9	12.4	14.3	12.6	12.1
05	16.7	16.5	8.4	6.9	13.0	16.3	19.0	16.3	15.7
06	19.7	19.7	10.1	8.6	15.5	19.6	22.9	19.8	19.1

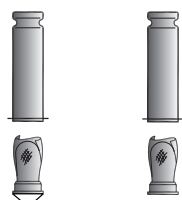

1. Orifice assembly with filter
2. Orifice assembly with filter for solder adaptor

Orifice assembly with filter

Orifice no.	Code no.
0X	068-2002
00	068-2003
01	068-2010
02	068-2015
03	068-2006
04	068-2007
05	068-2008
06	068-2009

Orifice assembly with filter for solder adaptor

Orifice no.	Code no.
0X	068-2089
00	068-2090
01	068-2091
02	068-2092
03	068-2093
04	068-2094
05	068-2095
06	068-2096



Filter

Filter type	Code no. Multi pack
For flare connection	068-0003
For solder adaptor	068-0015

The adaptor is for use with thermostatic expansion valves T2 and TE2. When the adaptor is fitted correctly it meets the sealing requirements of DIN 8964. The flare orifice in T2 and TE2 can be used with a solder adaptor when the orifice filter

is replaced with a specific filter intended for solder adaptors.

Only in this way the sealing requirements of DIN 8964 can be fulfilled. Solder adaptors for filter driers (FSA) **must not be used** on the T2 inlet.

Data sheet | Thermostatic expansion valves, type T2 / TE2

Solder adaptor



The adaptor is for use with thermostatic expansion valves T2 and TE2 with flare x solder connections. When the adaptor is fitted correctly it meets the sealing requirements of DIN 8964.

The adaptor offers the following advantages:

- The orifice assembly can be replaced.
- The filter can be cleaned or replaced.

When using the solder adapter, a special orifice assembly is required. Please use the following tables to select both the appropriate adapter and orifice assembly.

Only in this way can the sealing requirements of DIN 8964 be fulfilled.

Solder adaptor for filter drier (FSA) may not be used in the T2 inlet.

Solder adaptor without orifice assembly and filter

Connection ODF solder	Code no.
1/4 in.	068-2062
6 mm	068-2063
3/8 in.	068-2060
10 mm	068-2061

Filter for solder adaptor

Description	Code no.
Filter excl. orifice assembly	068-0015

Bulb strap (Danfoss patented)

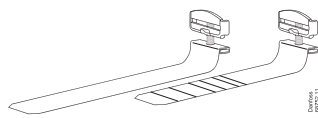

Each valve is delivered with a Danfoss patented bulb strap. Spares can be ordered.

Description	Pack mode	Quantity / pack	Code no.
Bulb strap 0.4 mm Max. 28 mm tube	I	45	068U3505
Bulb strap 0.4 mm Max. 50 mm tube	I	45	068U3506
Bulb strap 0.4 mm Max. 28 mm tube	M	25	068U3507
Bulb strap 0.4 mm Max. 50 mm tube	M	25	068U3508

How to select a valve

Example:

Refrigerant = R407C
 Q (capacity) = 1.1kW
 T_{cond} (condensing temperature) = 25 °C
 T_{evap} (evaporator temperature) = -30 °C
 T_{sub} (subcooling temperature) = 2 K
 D_{pd} (distributer pressure drop) = 1 bar

Q (capacity) = 1.1kW
 f_{sub} (subcooling correction factor) = 0.98
 f_p (distribution correction factor) = 0.96

$$\frac{Q}{f_{sub} \times f_p} = \text{Selected capacity}$$

$$\frac{1.1}{0.98 \times 0.96} = 1.17 \text{ kW}$$

The selection will be:
 TE2 orifice 00 (1.21 kW > 1.17 kW)

Capacity in kW, range N -40 °C to 10 °C. Opening superheat sh= 6 K

Valve type	Orifice no.	Cond. temp. [°C]	Evaporating [°C]			
			-40	-30	-20	-10
T2 / TE2	0X	25	0.76	0.83	0.88	0.90
T2 / TE2	00		0.99	1.21	1.42	1.60
T2 / TE2	01		1.41	1.80	2.27	2.77

Subcooling correction factor 'fsub'

Subcooling [K]	2	4	10	15
Correction factor	0.98	1.00	1.07	1.12

*Distributer correction factor 'fp' *)*

Pressure drop [bar]		Evaporating temp. [°C]			
		-40	-35	-30	-25
"Pressure drop [bar]"	0	1	1	1	1
	1	0.96	0.96	0.96	0.96
	1.5	0.94	0.94	0.94	0.94
	2	0.92	0.92	0.92	0.92

*) calculated at 32 °C condensing temperature

Capacity

Capacity in kW, range N -40 °C to 10 °C. Opening superheat sh= 6 K

R22

Valve type	Orifice no.	Cond. temp. [°C]	Evaporating [°C]					
			-40	-30	-20	-10	0	10
			Capacity [kW]					
T2 / TE2	0X	25	0.75	0.82	0.86	0.86	0.81	0.68
T2 / TE2	00		0.95	1.18	1.39	1.53	1.55	1.37
T2 / TE2	01		1.32	1.72	2.18	2.63	2.91	2.78
T2 / TE2	02		1.49	1.98	2.57	3.24	3.82	3.88
T2 / TE2	03		2.49	3.32	4.32	5.43	6.40	6.57
T2 / TE2	04		3.59	4.79	6.35	8.16	9.72	9.88
T2 / TE2	05		4.69	6.25	8.30	10.80	13.10	13.50
T2 / TE2	06		5.53	7.36	9.73	12.70	15.40	16.00

Valve type	Orifice no.	Cond. temp. [°C]	Evaporating [°C]					
			-40	-30	-20	-10	0	10
			Capacity [kW]					
T2 / TE2	0X	35	0.78	0.86	0.91	0.93	0.92	0.85
T2 / TE2	00		0.99	1.23	1.47	1.67	1.77	1.72
T2 / TE2	01		1.37	1.80	2.31	2.86	3.33	3.50
T2 / TE2	02		1.56	2.08	2.74	3.54	4.38	4.92
T2 / TE2	03		2.62	3.51	4.62	5.96	7.39	8.35
T2 / TE2	04		3.85	5.12	6.83	8.98	11.20	12.70
T2 / TE2	05		5.03	6.68	8.93	11.90	15.30	17.50
T2 / TE2	06		5.89	7.82	10.40	13.90	17.90	20.70

Valve type	Orifice no.	Cond. temp. [°C]	Evaporating [°C]					
			-40	-30	-20	-10	0	10
			Capacity [kW]					
T2 / TE2	0X	45	0.80	0.88	0.94	0.97	0.98	0.95
T2 / TE2	00		1.01	1.26	1.52	1.75	1.90	1.94
T2 / TE2	01		1.41	1.85	2.39	3.00	3.59	3.96
T2 / TE2	02		1.61	2.14	2.84	3.72	4.74	5.60
T2 / TE2	03		2.71	3.64	4.82	6.32	8.08	9.63
T2 / TE2	04		4.06	5.37	7.14	9.47	12.20	14.50
T2 / TE2	05		5.30	7.01	9.37	12.60	16.70	20.30
T2 / TE2	06		6.19	8.18	10.90	14.70	19.50	24.00

Valve type	Orifice no.	Cond. temp. [°C]	Evaporating [°C]					
			-40	-30	-20	-10	0	10
			Capacity [kW]					
T2 / TE2	0X	55	0.79	0.88	0.94	0.98	1.00	0.99
T2 / TE2	00		1.01	1.26	1.53	1.77	1.95	2.04
T2 / TE2	01		1.42	1.87	2.42	3.06	3.71	4.19
T2 / TE2	02		1.63	2.18	2.89	3.81	4.92	5.95
T2 / TE2	03		2.76	3.70	4.93	6.51	8.46	10.30
T2 / TE2	04		4.23	5.53	7.32	9.68	12.50	15.30
T2 / TE2	05		5.52	7.24	9.64	13.00	17.30	21.70
T2 / TE2	06		6.42	8.43	11.20	15.10	20.30	25.80

Subcooling correction factor 'fsub'

Subcooling [K]	2	4	10	15	20	25	30	35	40	45	50
Correction factor	0.98	1.00	1.05	1.10	1.14	1.19	1.23	1.28	1.32	1.36	1.41

Distributor correction factor 'fp' *)

Pressure drop [bar]	Evaporating temp. [°C]											
	-40	-35	-30	-25	-20	-15	-10	-5	0	5	10	15
0	1	1	1	1	1	1	1	1	1	1	1	1
1	0.96	0.95	0.95	0.95	0.95	0.95	0.94	0.94	0.93	0.92	0.91	0.89
1.5	0.93	0.93	0.93	0.93	0.92	0.92	0.91	0.91	0.90	0.88	0.86	0.82
2	0.91	0.91	0.90	0.90	0.90	0.89	0.88	0.87	0.86	0.84	0.81	0.76

*) calculated at 32 °C condensing temperature

Capacity

Capacity in kW, range B -60 °C to -25 °C. Opening superheat sh= 6 K

R22

Valve type	Orifice no.	Cond. temp. [°C]	Evaporating [°C]			
			-60	-50	-40	-30
			Capacity [kW]			
T2 / TE2	0X	25	0.54	0.67	0.78	0.84
T2 / TE2	00		0.55	0.77	1.03	1.28
T2 / TE2	01		0.72	1.06	1.47	1.95
T2 / TE2	02		0.80	1.17	1.66	2.26
T2 / TE2	03		1.32	1.94	2.76	3.77
T2 / TE2	04		1.87	2.76	3.95	5.45
T2 / TE2	05		2.45	3.60	5.15	7.14
T2 / TE2	06		2.91	4.26	6.10	8.50

Valve type	Orifice no.	Cond. temp. [°C]	Evaporating [°C]			
			-60	-50	-40	-30
			Capacity [kW]			
T2 / TE2	0X	35	0.56	0.69	0.80	0.88
T2 / TE2	00		0.56	0.79	1.06	1.34
T2 / TE2	01		0.74	1.08	1.52	2.04
T2 / TE2	02		0.82	1.20	1.72	2.36
T2 / TE2	03		1.35	1.99	2.85	3.93
T2 / TE2	04		1.90	2.81	4.04	5.63
T2 / TE2	05		2.50	3.66	5.26	7.36
T2 / TE2	06		2.96	4.33	6.21	8.71

Valve type	Orifice no.	Cond. temp. [°C]	Evaporating [°C]			
			-60	-50	-40	-30
			Capacity [kW]			
T2 / TE2	0X	45	0.56	0.70	0.82	0.91
T2 / TE2	00		0.57	0.80	1.08	1.37
T2 / TE2	01		0.75	1.10	1.55	2.09
T2 / TE2	02		0.82	1.22	1.74	2.41
T2 / TE2	03		1.36	2.01	2.88	4.00
T2 / TE2	04		1.91	2.82	4.06	5.70
T2 / TE2	05		2.52	3.68	5.29	7.42
T2 / TE2	06		2.98	4.35	6.23	8.75

Valve type	Orifice no.	Cond. temp. [°C]	Evaporating [°C]			
			-60	-50	-40	-30
			Capacity [kW]			
T2 / TE2	0X	55	0.56	0.70	0.82	0.91
T2 / TE2	00		0.57	0.80	1.08	1.38
T2 / TE2	01		0.75	1.10	1.55	2.10
T2 / TE2	02		0.82	1.21	1.74	2.41
T2 / TE2	03		1.36	2.00	2.87	4.01
T2 / TE2	04		1.89	2.79	4.03	5.66
T2 / TE2	05		2.52	3.67	5.25	7.37
T2 / TE2	06		2.98	4.32	6.17	8.66

Subcooling correction factor 'fsub'

Subcooling [K]	2	4	10	15	20	25	30	35	40	45	50
Correction factor	0.98	1.00	1.07	1.12	1.18	1.23	1.28	1.34	1.39	1.45	1.50

Distributor correction factor 'fp'*)

Pressure drop [bar]	Evaporating temp. [°C]											
	-40	-35	-30	-25	-20	-15	-10	-5	0	5	10	15
0	1	1	1	1	1	1	1	1	1	1	1	1
1	0.96	0.96	0.96	0.96	0.96	0.96	0.95	0.95	0.95	0.94	0.93	0.92
1.5	0.94	0.94	0.94	0.94	0.94	0.93	0.93	0.93	0.92	0.91	0.90	0.88
2	0.92	0.92	0.92	0.92	0.91	0.91	0.91	0.90	0.89	0.88	0.86	0.84

*) calculated at 32 °C condensing temperature

Capacity

Capacity in kW, range N -40 °C to 10 °C. Opening superheat sh= 6 K

R407C

Valve type	Orifice no.	Cond. temp. [°C]	Evaporating [°C]					
			-40	-30	-20	-10	0	10
			Capacity [kW]					
T2 / TE2	0X	25	0.76	0.83	0.88	0.90	0.88	0.81
T2 / TE2	00		0.99	1.21	1.42	1.60	1.69	1.63
T2 / TE2	01		1.41	1.80	2.27	2.77	3.19	3.31
T2 / TE2	02		1.59	2.06	2.67	3.40	4.18	4.64
T2 / TE2	03		2.65	3.44	4.46	5.73	7.07	7.85
T2 / TE2	04		3.86	4.98	6.44	8.35	10.60	12.50
T2 / TE2	05		5.04	6.52	8.46	11.00	14.00	16.30
T2 / TE2	06		5.94	7.71	10.10	13.20	16.80	19.40

Valve type	Orifice no.	Cond. temp. [°C]	Evaporating [°C]					
			-40	-30	-20	-10	0	10
			Capacity [kW]					
T2 / TE2	0X	35	0.76	0.84	0.90	0.94	0.95	0.92
T2 / TE2	00		0.99	1.22	1.45	1.67	1.81	1.85
T2 / TE2	01		1.40	1.81	2.32	2.88	3.43	3.76
T2 / TE2	02		1.59	2.08	2.72	3.54	4.48	5.28
T2 / TE2	03		2.66	3.48	4.57	5.98	7.62	8.98
T2 / TE2	04		3.93	5.10	6.65	8.74	11.40	14.20
T2 / TE2	05		5.13	6.66	8.73	11.50	15.10	18.60
T2 / TE2	06		6.01	7.85	10.40	13.80	18.10	22.20

Valve type	Orifice no.	Cond. temp. [°C]	Evaporating [°C]					
			-40	-30	-20	-10	0	10
			Capacity [kW]					
T2 / TE2	0X	45	0.73	0.82	0.89	0.94	0.97	0.97
T2 / TE2	00		0.95	1.19	1.43	1.67	1.85	1.94
T2 / TE2	01		1.36	1.77	2.28	2.88	3.50	3.97
T2 / TE2	02		1.55	2.04	2.69	3.54	4.58	5.58
T2 / TE2	03		2.60	3.42	4.53	6.01	7.82	9.52
T2 / TE2	04		3.89	5.07	6.66	8.83	11.70	15.00
T2 / TE2	05		5.06	6.62	8.73	11.70	15.60	19.80
T2 / TE2	06		5.90	7.76	10.30	13.90	18.70	23.60

Valve type	Orifice no.	Cond. temp. [°C]	Evaporating [°C]					
			-40	-30	-20	-10	0	10
			Capacity [kW]					
T2 / TE2	0X	55	0.68	0.77	0.85	0.91	0.95	0.96
T2 / TE2	00		0.89	1.12	1.37	1.61	1.81	1.93
T2 / TE2	01		1.27	1.67	2.18	2.78	3.43	3.96
T2 / TE2	02		1.46	1.93	2.57	3.42	4.49	5.58
T2 / TE2	03		2.46	3.27	4.36	5.84	7.71	9.60
T2 / TE2	04		3.74	4.90	6.48	8.65	11.60	15.10
T2 / TE2	05		4.85	6.39	8.49	11.40	15.40	20.00
T2 / TE2	06		5.61	7.45	9.99	13.60	18.50	24.00

Subcooling correction factor 'fsub'

Subcooling [K]	2	4	10	15	20	25	30	35	40	45	50
Correction factor	0.98	1.00	1.07	1.12	1.18	1.23	1.28	1.34	1.39	1.45	1.50

Distributor correction factor 'fp' *)

Pressure drop [bar]	Evaporating temp. [°C]											
	-40	-35	-30	-25	-20	-15	-10	-5	0	5	10	15
0	1	1	1	1	1	1	1	1	1	1	1	1
1	0.96	0.96	0.96	0.96	0.96	0.96	0.95	0.95	0.95	0.94	0.93	0.92
1.5	0.94	0.94	0.94	0.94	0.94	0.93	0.93	0.93	0.92	0.91	0.90	0.88
2	0.92	0.92	0.92	0.92	0.91	0.91	0.91	0.90	0.89	0.88	0.86	0.84

*) calculated at 32 °C condensing temperature

Capacity

Capacity in kW, range N -40 °C to 10 °C. Opening superheat sh= 6 K

R134a

Valve type	Orifice no.	Cond. temp. [°C]	Evaporating [°C]					
			-40	-30	-20	-10	0	10
			Capacity [kW]					
T2 / TE2	0X	25	0.48	0.54	0.59	0.62	0.61	0.54
T2 / TE2	00		0.52	0.67	0.82	0.95	1.03	0.98
T2 / TE2	01		0.70	0.92	1.19	1.48	1.72	1.77
T2 / TE2	02		0.78	1.03	1.35	1.73	2.08	2.24
T2 / TE2	03		1.31	1.72	2.27	2.89	3.49	3.76
T2 / TE2	04		1.89	2.49	3.28	4.21	5.15	5.69
T2 / TE2	05		2.50	3.28	4.33	5.57	6.80	7.48
T2 / TE2	06		2.98	3.93	5.20	6.69	8.16	8.96

Valve type	Orifice no.	Cond. temp. [°C]	Evaporating [°C]					
			-40	-30	-20	-10	0	10
			Capacity [kW]					
T2 / TE2	0X	35	0.49	0.57	0.63	0.67	0.69	0.66
T2 / TE2	00		0.54	0.69	0.86	1.03	1.17	1.22
T2 / TE2	01		0.72	0.96	1.25	1.60	1.95	2.20
T2 / TE2	02		0.81	1.07	1.43	1.87	2.36	2.79
T2 / TE2	03		1.36	1.80	2.40	3.14	3.96	4.69
T2 / TE2	04		2.02	2.64	3.51	4.60	5.85	7.07
T2 / TE2	05		2.66	3.48	4.62	6.06	7.72	9.31
T2 / TE2	06		3.15	4.14	5.51	7.24	9.24	11.10

Valve type	Orifice no.	Cond. temp. [°C]	Evaporating [°C]					
			-40	-30	-20	-10	0	10
			Capacity [kW]					
T2 / TE2	0X	45	0.49	0.57	0.64	0.69	0.73	0.74
T2 / TE2	00		0.54	0.70	0.88	1.07	1.25	1.36
T2 / TE2	01		0.73	0.97	1.28	1.66	2.08	2.46
T2 / TE2	02		0.82	1.09	1.46	1.93	2.51	3.11
T2 / TE2	03		1.38	1.83	2.45	3.25	4.22	5.24
T2 / TE2	04		2.10	2.73	3.63	4.80	6.24	7.89
T2 / TE2	05		2.76	3.59	4.76	6.31	8.23	10.40
T2 / TE2	06		3.25	4.24	5.64	7.51	9.82	12.40

Valve type	Orifice no.	Cond. temp. [°C]	Evaporating [°C]					
			-40	-30	-20	-10	0	10
			Capacity [kW]					
T2 / TE2	0X	55	0.47	0.56	0.63	0.69	0.74	0.76
T2 / TE2	00		0.53	0.69	0.87	1.07	1.27	1.43
T2 / TE2	01		0.72	0.95	1.26	1.65	2.11	2.57
T2 / TE2	02		0.81	1.08	1.45	1.94	2.55	3.24
T2 / TE2	03		1.38	1.82	2.44	3.27	4.30	5.50
T2 / TE2	04		2.14	2.77	3.66	4.85	6.38	8.25
T2 / TE2	05		2.81	3.63	4.80	6.37	8.40	10.90
T2 / TE2	06		3.30	4.26	5.65	7.54	10.00	13.00

Subcooling correction factor 'fsub'

Subcooling [K]	2	4	10	15	20	25	30	35	40	45	50
Correction factor	0.98	1.00	1.07	1.12	1.18	1.23	1.29	1.34	1.40	1.45	1.50

Distributor correction factor 'fp' *)

Pressure drop [bar]	Evaporating temp. [°C]											
	-40	-35	-30	-25	-20	-15	-10	-5	0	5	10	15
0	1	1	1	1	1	1	1	1	1	1	1	1
1	0.93	0.93	0.93	0.93	0.92	0.92	0.92	0.91	0.90	0.89	0.87	0.83
1.5	0.90	0.89	0.89	0.89	0.88	0.88	0.87	0.86	0.84	0.82	0.79	0.74
2	0.86	0.86	0.85	0.85	0.84	0.83	0.82	0.81	0.79	0.76	0.71	0.62

*) calculated at 32 °C condensing temperature

Capacity

Capacity in kW, range N -40 °C to 10 °C. Opening superheat sh= 6 K

R404A

Valve type	Orifice no.	Cond. temp. [°C]	Evaporating [°C]					
			-40	-30	-20	-10	0	10
			Capacity [kW]					
T2 / TE2	0X	25	0.55	0.61	0.64	0.65	0.62	0.54
T2 / TE2	00		0.72	0.92	1.09	1.21	1.22	1.08
T2 / TE2	01		1.00	1.38	1.81	2.20	2.40	2.25
T2 / TE2	02		1.12	1.58	2.17	2.79	3.25	3.22
T2 / TE2	03		1.86	2.65	3.65	4.72	5.49	5.42
T2 / TE2	04		2.68	3.83	5.36	7.12	8.53	8.69
T2 / TE2	05		3.51	5.04	7.06	9.38	11.20	11.30
T2 / TE2	06		4.15	5.99	8.43	11.20	13.40	13.30

Valve type	Orifice no.	Cond. temp. [°C]	Evaporating [°C]					
			-40	-30	-20	-10	0	10
			Capacity [kW]					
T2 / TE2	0X	35	0.52	0.59	0.64	0.67	0.68	0.64
T2 / TE2	00		0.67	0.88	1.08	1.25	1.34	1.29
T2 / TE2	01		0.95	1.33	1.79	2.28	2.64	2.70
T2 / TE2	02		1.07	1.53	2.15	2.90	3.59	3.89
T2 / TE2	03		1.78	2.57	3.64	4.93	6.11	6.57
T2 / TE2	04		2.60	3.75	5.37	7.45	9.53	10.60
T2 / TE2	05		3.40	4.93	7.07	9.82	12.50	13.70
T2 / TE2	06		4.00	5.83	8.40	11.70	14.90	16.30

Valve type	Orifice no.	Cond. temp. [°C]	Evaporating [°C]					
			-40	-30	-20	-10	0	10
			Capacity [kW]					
T2 / TE2	0X	45	0.46	0.54	0.60	0.65	0.68	0.67
T2 / TE2	00		0.61	0.81	1.01	1.20	1.34	1.38
T2 / TE2	01		0.86	1.22	1.68	2.19	2.66	2.87
T2 / TE2	02		0.97	1.41	2.02	2.81	3.64	4.16
T2 / TE2	03		1.63	2.38	3.43	4.80	6.23	7.06
T2 / TE2	04		2.43	3.50	5.08	7.26	9.74	11.40
T2 / TE2	05		3.17	4.60	6.69	9.58	12.90	14.90
T2 / TE2	06		3.71	5.41	7.92	11.40	15.40	17.70

Valve type	Orifice no.	Cond. temp. [°C]	Evaporating [°C]					
			-40	-30	-20	-10	0	10
			Capacity [kW]					
T2 / TE2	0X	55	0.39	0.47	0.54	0.59	0.62	0.64
T2 / TE2	00		0.52	0.70	0.89	1.07	1.23	1.30
T2 / TE2	01		0.74	1.06	1.47	1.96	2.44	2.73
T2 / TE2	02		0.85	1.23	1.78	2.52	3.35	3.96
T2 / TE2	03		1.43	2.09	3.03	4.32	5.78	6.76
T2 / TE2	04		2.17	3.10	4.50	6.51	8.98	10.90
T2 / TE2	05		2.83	4.07	5.92	8.61	11.90	14.40
T2 / TE2	06		3.29	4.77	6.99	10.30	14.30	17.20

Subcooling correction factor 'fsub'

Subcooling [K]	2	4	10	15	20	25	30	35	40	45	50
Correction factor	0.97	1.00	1.09	1.16	1.23	1.30	1.38	1.45	1.52	1.59	1.65

Distributor correction factor 'fp' *)

Pressure drop [bar]	Evaporating temp. [°C]											
	-40	-35	-30	-25	-20	-15	-10	-5	0	5	10	15
0	1	1	1	1	1	1	1	1	1	1	1	1
1	0.96	0.96	0.96	0.96	0.96	0.96	0.95	0.95	0.94	0.94	0.92	0.91
1.5	0.94	0.94	0.94	0.94	0.94	0.93	0.93	0.92	0.91	0.90	0.88	0.86
2	0.92	0.92	0.92	0.92	0.91	0.91	0.90	0.89	0.88	0.87	0.84	0.80

*) calculated at 32 °C condensing temperature

Capacity

Capacity in kW, range B, -60 °C to -25 °C, opening superheat sh= 6 K

R404A

Valve type	Orifice no.	Cond. temp. [°C]	Evaporating [°C]			
			-60	-50	-40	-30
			Capacity [kW]			
T2 / TE2	0X	25	0.44	0.51	0.58	0.63
T2 / TE2	00		0.50	0.65	0.83	1.02
T2 / TE2	01		0.68	0.90	1.22	1.62
T2 / TE2	02		0.75	1.00	1.39	1.91
T2 / TE2	03		1.22	1.64	2.30	3.22
T2 / TE2	04		1.69	2.31	3.23	4.46
T2 / TE2	05		2.20	3.02	4.22	5.82
T2 / TE2	06		2.60	3.55	4.98	6.92

Valve type	Orifice no.	Cond. temp. [°C]	Evaporating [°C]			
			-60	-50	-40	-30
			Capacity [kW]			
T2 / TE2	0X	35	0.41	0.49	0.56	0.62
T2 / TE2	00		0.47	0.61	0.80	1.00
T2 / TE2	01		0.64	0.86	1.18	1.59
T2 / TE2	02		0.70	0.96	1.34	1.88
T2 / TE2	03		1.16	1.58	2.24	3.18
T2 / TE2	04		1.72	2.31	3.22	4.47
T2 / TE2	05		2.23	3.01	4.19	5.83
T2 / TE2	06		2.63	3.51	4.90	6.87

Valve type	Orifice no.	Cond. temp. [°C]	Evaporating [°C]			
			-60	-50	-40	-30
			Capacity [kW]			
T2 / TE2	0X	45	0.36	0.44	0.52	0.58
T2 / TE2	00		0.41	0.55	0.73	0.93
T2 / TE2	01		0.56	0.77	1.08	1.48
T2 / TE2	02		0.63	0.86	1.23	1.76
T2 / TE2	03		1.04	1.44	2.07	2.99
T2 / TE2	04		1.68	2.20	3.04	4.23
T2 / TE2	05		2.16	2.84	3.94	5.52
T2 / TE2	06		2.57	3.30	4.57	6.46

Valve type	Orifice no.	Cond. temp. [°C]	Evaporating [°C]			
			-60	-50	-40	-30
			Capacity [kW]			
T2 / TE2	0X	55	0.29	0.36	0.44	0.50
T2 / TE2	00		0.33	0.46	0.62	0.81
T2 / TE2	01		0.46	0.64	0.92	1.29
T2 / TE2	02		0.51	0.73	1.06	1.54
T2 / TE2	03		0.86	1.22	1.80	2.65
T2 / TE2	04		1.56	1.96	2.67	3.73
T2 / TE2	05		1.98	2.50	3.44	4.85
T2 / TE2	06		2.39	2.93	3.97	5.63

Subcooling correction factor 'fsub'

Subcooling [K]	2	4	10	15	20	25	30	35	40	45	50
Correction factor	0.97	1.00	1.10	1.19	1.27	1.35	1.43	1.52	1.60	1.68	1.76

Distributor correction factor 'fp' *)

Pressure drop [bar]		Evaporating temp. [°C]							
		-60	-55	-50	-45	-40	-35	-30	-25
"Pressure drop [bar]"	0	1	1	1	1	1	1	1	1
	1	0.97	0.96	0.96	0.96	0.96	0.96	0.96	0.96
	1.5	0.95	0.95	0.95	0.94	0.94	0.94	0.94	0.94
	2	0.93	0.93	0.93	0.93	0.92	0.92	0.92	0.92

*) calculated at 32 °C condensing temperature

Capacity

Capacity in kW, range N -40 °C to 10 °C. Opening superheat sh= 6 K

R407F

Valve type	Orifice no.	Cond. temp. [°C]	Evaporating [°C]					
			-40	-30	-20	-10	0	10
			Capacity [kW]					
T2 / TE2	0X	25	0.84	0.92	0.96	0.98	0.95	0.86
T2 / TE2	00		1.1	1.4	1.6	1.8	1.8	1.7
T2 / TE2	01		1.6	2.0	2.6	3.1	3.6	3.6
T2 / TE2	02		1.8	2.3	3.0	3.9	4.8	5.1
T2 / TE2	03		2.9	3.9	5.1	6.6	8.1	8.7
T2 / TE2	04		4.3	5.6	7.4	9.6	12.2	14.0
T2 / TE2	05		5.6	7.4	9.7	12.7	16.1	18.1
T2 / TE2	06		6.6	8.7	11.6	15.2	19.3	21.5

Valve type	Orifice no.	Cond. temp. [°C]	Evaporating [°C]					
			-40	-30	-20	-10	0	10
			Capacity [kW]					
T2 / TE2	0X	35	0.85	0.93	0.99	1.0	1.0	0.98
T2 / TE2	00		1.1	1.4	1.6	1.9	2.0	2.0
T2 / TE2	01		1.6	2.1	2.7	3.3	3.9	4.1
T2 / TE2	02		1.8	2.4	3.1	4.1	5.2	5.9
T2 / TE2	03		3.0	4.0	5.3	7.0	8.8	10.0
T2 / TE2	04		4.4	5.8	7.7	10.2	13.3	16.0
T2 / TE2	05		5.8	7.6	10.1	13.5	17.5	20.9
T2 / TE2	06		6.7	9.0	12.0	16.1	21.0	24.8

Valve type	Orifice no.	Cond. temp. [°C]	Evaporating [°C]					
			-40	-30	-20	-10	0	10
			Capacity [kW]					
T2 / TE2	0X	45	0.83	0.92	0.99	1.0	1.1	1.0
T2 / TE2	00		1.1	1.4	1.6	1.9	2.0	2.1
T2 / TE2	01		1.5	2.0	2.6	3.3	4.0	4.4
T2 / TE2	02		1.8	2.3	3.1	4.1	5.3	6.3
T2 / TE2	03		3.0	4.0	5.3	7.1	9.1	10.7
T2 / TE2	04		4.4	5.9	7.8	10.4	13.8	17.1
T2 / TE2	05		5.8	7.6	10.2	13.8	18.3	22.4
T2 / TE2	06		6.7	8.9	12.1	16.4	21.9	26.6

Valve type	Orifice no.	Cond. temp. [°C]	Evaporating [°C]					
			-40	-30	-20	-10	0	10
			Capacity [kW]					
T2 / TE2	0X	55	0.79	0.89	0.96	1.0	1.0	1.0
T2 / TE2	00		1.0	1.3	1.6	1.8	2.0	2.1
T2 / TE2	01		1.5	2.0	2.6	3.3	3.9	4.4
T2 / TE2	02		1.7	2.3	3.0	4.1	5.3	6.4
T2 / TE2	03		2.9	3.8	5.2	7.0	9.1	10.9
T2 / TE2	04		4.3	5.7	7.7	10.3	13.8	17.4
T2 / TE2	05		5.6	7.5	10.1	13.7	18.4	22.9
T2 / TE2	06		6.5	8.7	11.9	16.3	22.1	27.4

Subcooling correction factor 'fsub'

Subcooling [K]	1	4	10	15	20	25	30	35	40	45	50
Correction factor	0.96	1.00	1.07	1.14	1.20	1.26	1.33	1.40	1.47	1.54	1.65

Distributor correction factor 'fp'*)

Pressure drop [bar]	Evaporating temp. [°C]											
	-40	-35	-30	-25	-20	-15	-10	-5	0	5	10	15
0	1	1	1	1	1	1	1	1	1	1	1	1
1	1.00	0.93	0.91	0.88	0.87	0.82	0.79	0.76	0.73	0.69	0.65	0.91
1.5	1.04	0.91	0.88	0.84	0.82	0.77	0.74	0.69	0.64	0.60	0.57	0.86
2	1.07	0.93	0.85	0.81	0.77	0.72	0.67	0.63	0.58	0.54	0.50	0.80

*) calculated at 32 °C condensing temperature

Capacity

Capacity in kW, range N -40 °C to 10 °C. Opening superheat sh= 6 K

R407A

Valve type	Orifice no.	Cond. temp. [°C]	Evaporating [°C]					
			-40	-30	-20	-10	0	10
			Capacity [kW]					
T2 / TE2	0X	25	0.74	0.81	0.86	0.87	0.85	0.77
T2 / TE2	00		0.97	1.2	1.4	1.6	1.7	1.6
T2 / TE2	01		1.4	1.8	2.3	2.8	3.2	3.2
T2 / TE2	02		1.6	2.1	2.7	3.5	4.3	4.6
T2 / TE2	03		2.6	3.4	4.6	5.9	7.3	7.8
T2 / TE2	04		3.8	5.0	6.6	8.6	11.0	12.6
T2 / TE2	05		5.0	6.5	8.6	11.4	14.5	16.4
T2 / TE2	06		5.8	7.7	10.3	13.6	17.3	19.4

Valve type	Orifice no.	Cond. temp. [°C]	Evaporating [°C]					
			-40	-30	-20	-10	0	10
			Capacity [kW]					
T2 / TE2	0X	35	0.74	0.82	0.88	0.91	0.91	0.88
T2 / TE2	00		0.97	1.2	1.4	1.7	1.8	1.8
T2 / TE2	01		1.4	1.8	2.3	2.9	3.4	3.7
T2 / TE2	02		1.6	2.1	2.8	3.6	4.6	5.3
T2 / TE2	03		2.6	3.5	4.7	6.2	7.8	9.0
T2 / TE2	04		3.9	5.1	6.8	9.0	11.9	14.4
T2 / TE2	05		5.0	6.7	8.9	12.0	15.7	18.7
T2 / TE2	06		5.9	7.9	10.6	14.3	18.8	22.2

Valve type	Orifice no.	Cond. temp. [°C]	Evaporating [°C]					
			-40	-30	-20	-10	0	10
			Capacity [kW]					
T2 / TE2	0X	45	0.72	0.80	0.87	0.91	0.93	0.92
T2 / TE2	00		0.94	1.2	1.4	1.7	1.8	1.9
T2 / TE2	01		1.3	1.8	2.3	2.9	3.5	3.9
T2 / TE2	02		1.5	2.0	2.7	3.7	4.7	5.6
T2 / TE2	03		2.6	3.4	4.6	6.2	8.1	9.5
T2 / TE2	04		3.8	5.1	6.8	9.2	12.2	15.2
T2 / TE2	05		5.0	6.6	8.9	12.1	16.2	19.9
T2 / TE2	06		5.8	7.8	10.6	14.5	19.4	23.7

Valve type	Orifice no.	Cond. temp. [°C]	Evaporating [°C]					
			-40	-30	-20	-10	0	10
			Capacity [kW]					
T2 / TE2	0X	55	0.67	0.76	0.83	0.88	0.91	0.92
T2 / TE2	00		0.88	1.1	1.4	1.6	1.8	1.9
T2 / TE2	01		1.3	1.7	2.2	2.8	3.5	3.9
T2 / TE2	02		1.4	1.9	2.6	3.5	4.6	5.6
T2 / TE2	03		2.4	3.3	4.5	6.1	8.0	9.6
T2 / TE2	04		3.7	4.9	6.6	9.0	12.1	15.4
T2 / TE2	05		4.8	6.4	8.7	11.9	16.1	20.3
T2 / TE2	06		5.5	7.5	10.3	14.2	19.4	24.2

Subcooling correction factor 'fsub'

Subcooling [K]	1	4	10	15	20	25	30	35	40	45	50
Correction factor	0.96	1.00	1.08	1.14	1.21	1.28	1.35	1.42	1.50	1.57	1.65

Distributor correction factor 'fp'*)

Pressure drop [bar]		Evaporating temp. [°C]											
		-40	-35	-30	-25	-20	-15	-10	-5	0	5	10	15
"Pressure drop [bar]"	0	1	1	1	1	1	1	1	1	1	1	1	
	1	0.97	0.93	0.92	0.89	0.86	0.83	0.80	0.78	0.74	0.72	0.67	0.91
	1.5	1.01	0.92	0.88	0.85	0.81	0.78	0.73	0.71	0.67	0.63	0.59	0.86
	2	1.01	0.90	0.86	0.82	0.77	0.74	0.69	0.63	0.59	0.56	0.52	0.80

*) calculated at 32 °C condensing temperature

Capacity

Capacity in kW, range N -40 °C to 10 °C. Opening superheat sh= 6 K

R448A

Valve type	Orifice no.	Cond. temp. [°C]	Evaporating [°C]					
			-40	-30	-20	-10	0	10
			Capacity [kW]					
T2 / TE2	0X	25	0.77	0.83	0.87	0.88	0.86	0.79
T2 / TE2	00		1.05	1.25	1.44	1.60	1.67	1.59
T2 / TE2	01		1.51	1.90	2.35	2.82	3.19	3.25
T2 / TE2	02		1.72	2.19	2.78	3.50	4.22	4.58
T2 / TE2	03		2.86	3.65	4.67	5.90	7.14	7.73
T2 / TE2	04		4.17	5.30	6.77	8.67	10.9	12.4
T2 / TE2	05		5.45	6.93	8.87	11.3	14.1	15.8
T2 / TE2	06		6.45	8.26	10.6	13.7	17.1	19.1

Valve type	Orifice no.	Cond. temp. [°C]	Evaporating [°C]					
			-40	-30	-20	-10	0	10
			Capacity [kW]					
T2 / TE2	0X	35	0.77	0.84	0.89	0.92	0.93	0.90
T2 / TE2	00		1.05	1.26	1.48	1.67	1.79	1.81
T2 / TE2	01		1.51	1.91	2.40	2.94	3.43	3.70
T2 / TE2	02		1.72	2.21	2.84	3.64	4.54	5.23
T2 / TE2	03		2.88	3.70	4.78	6.16	7.70	8.87
T2 / TE2	04		4.24	5.42	6.99	9.08	11.7	14.1
T2 / TE2	05		5.53	7.08	9.15	11.9	15.2	18.1
T2 / TE2	06		6.52	8.40	10.9	14.3	18.5	22.0

Valve type	Orifice no.	Cond. temp. [°C]	Evaporating [°C]					
			-40	-30	-20	-10	0	10
			Capacity [kW]					
T2 / TE2	0X	45	0.75	0.82	0.88	0.93	0.95	0.94
T2 / TE2	00		1.01	1.23	1.46	1.67	1.83	1.90
T2 / TE2	01		1.47	1.87	2.37	2.94	3.51	3.90
T2 / TE2	02		1.67	2.16	2.81	3.65	4.64	5.52
T2 / TE2	03		2.82	3.64	4.75	6.20	7.91	9.41
T2 / TE2	04		4.20	5.39	6.99	9.18	12.0	14.9
T2 / TE2	05		5.47	7.03	9.16	12.0	15.7	19.2
T2 / TE2	06		6.41	8.31	10.9	14.5	19.0	23.4

Valve type	Orifice no.	Cond. temp. [°C]	Evaporating [°C]					
			-40	-30	-20	-10	0	10
			Capacity [kW]					
T2 / TE2	0X	55	0.70	0.78	0.84	0.89	0.93	0.94
T2 / TE2	00		0.95	1.17	1.39	1.61	1.79	1.89
T2 / TE2	01		1.38	1.77	2.26	2.84	3.44	3.90
T2 / TE2	02		1.58	2.06	2.70	3.54	4.56	5.54
T2 / TE2	03		2.68	3.49	4.59	6.04	7.82	9.51
T2 / TE2	04		4.06	5.23	6.82	9.01	11.9	15.1
T2 / TE2	05		5.26	6.81	8.92	11.8	15.6	19.4
T2 / TE2	06		6.13	8.00	10.6	14.2	19.0	23.8

Subcooling correction factor 'fsub'

Subcooling [K]	2	4	10	15	20	25	30	35	40	45	50
Correction factor	0.98	1.00	1.07	1.13	1.19	1.25	1.31	1.37	1.42	1.48	1.54

Distributor correction factor 'fp' *)

Pressure drop [bar]		Evaporating temp. [°C]											
		-40	-35	-30	-25	-20	-15	-10	-5	0	5	10	15
"Pressure drop [bar]"	0	1	1	1	1	1	1	1	1	1	1	1	1
	1	0.96	0.96	0.96	0.96	0.96	0.96	0.96	0.95	0.95	0.94	0.94	0.93
	1.5	0.95	0.94	0.94	0.94	0.94	0.94	0.93	0.93	0.92	0.92	0.90	0.89
	2	0.93	0.93	0.92	0.92	0.92	0.92	0.91	0.90	0.90	0.89	0.87	0.85

*) calculated at 32 °C condensing temperature

Capacity

Capacity in kW, range N -40 °C to 10 °C. Opening superheat sh= 6 K

R449A

Valve type	Orifice no.	Cond. temp. [°C]	Evaporating [°C]					
			-40	-30	-20	-10	0	10
			Capacity [kW]					
T2 / TE2	0X	25	0.76	0.82	0.85	0.87	0.85	0.78
T2 / TE2	00		1.05	1.24	1.42	1.57	1.63	1.56
T2 / TE2	01		1.53	1.90	2.32	2.76	3.12	3.17
T2 / TE2	02		1.74	2.19	2.76	3.43	4.11	4.45
T2 / TE2	03		2.91	3.66	4.63	5.79	6.95	7.52
T2 / TE2	04		4.24	5.33	6.75	8.54	10.6	12.0
T2 / TE2	05		5.55	6.98	8.84	11.2	13.7	15.3
T2 / TE2	06		6.59	8.32	10.6	13.5	16.6	18.5

Valve type	Orifice no.	Cond. temp. [°C]	Evaporating [°C]					
			-40	-30	-20	-10	0	10
			Capacity [kW]					
T2 / TE2	0X	35	0.76	0.82	0.87	0.90	0.91	0.88
T2 / TE2	00		1.05	1.25	1.45	1.63	1.75	1.77
T2 / TE2	01		1.53	1.91	2.36	2.87	3.34	3.61
T2 / TE2	02		1.74	2.20	2.81	3.56	4.40	5.07
T2 / TE2	03		2.92	3.70	4.73	6.03	7.48	8.60
T2 / TE2	04		4.30	5.43	6.93	8.92	11.4	13.6
T2 / TE2	05		5.61	7.10	9.09	11.67	14.8	17.4
T2 / TE2	06		6.63	8.43	10.9	14.1	17.9	21.2

Valve type	Orifice no.	Cond. temp. [°C]	Evaporating [°C]					
			-40	-30	-20	-10	0	10
			Capacity [kW]					
T2 / TE2	0X	45	0.74	0.81	0.87	0.91	0.93	0.93
T2 / TE2	00		1.01	1.22	1.43	1.63	1.79	1.86
T2 / TE2	01		1.48	1.86	2.33	2.87	3.41	3.80
T2 / TE2	02		1.69	2.15	2.77	3.56	4.49	5.35
T2 / TE2	03		2.84	3.63	4.68	6.05	7.66	9.10
T2 / TE2	04		4.23	5.37	6.91	8.99	11.6	14.4
T2 / TE2	05		5.51	7.02	9.06	11.8	15.2	18.5
T2 / TE2	06		6.49	8.31	10.8	14.2	18.4	22.6

Valve type	Orifice no.	Cond. temp. [°C]	Evaporating [°C]					
			-40	-30	-20	-10	0	10
			Capacity [kW]					
T2 / TE2	0X	55	0.69	0.76	0.82	0.87	0.91	0.92
T2 / TE2	00		0.95	1.15	1.36	1.57	1.74	1.85
T2 / TE2	01		1.39	1.76	2.22	2.76	3.34	3.80
T2 / TE2	02		1.59	2.04	2.64	3.44	4.41	5.36
T2 / TE2	03		2.69	3.46	4.49	5.87	7.54	9.15
T2 / TE2	04		4.06	5.18	6.71	8.78	11.5	14.5
T2 / TE2	05		5.27	6.76	8.78	11.5	15.0	18.7
T2 / TE2	06		6.17	7.96	10.4	13.9	18.3	22.9

Subcooling correction factor 'fsub'

Subcooling [K]	2	4	10	15	20	25	30	35	40	45	50
Correction factor	0.98	1.00	1.07	1.13	1.19	1.25	1.31	1.37	1.43	1.49	1.55

Distributor correction factor 'fp'*)

Pressure drop [bar]	Evaporating temp. [°C]											
	-40	-35	-30	-25	-20	-15	-10	-5	0	5	10	15
"Pressure drop [bar]"	0	1	1	1	1	1	1	1	1	1	1	1
	1	0.96	0.96	0.96	0.96	0.96	0.96	0.95	0.95	0.94	0.94	0.93
	1.5	0.95	0.94	0.94	0.94	0.94	0.94	0.93	0.93	0.92	0.91	0.89
	2	0.93	0.93	0.92	0.92	0.92	0.91	0.91	0.90	0.90	0.88	0.84

*) calculated at 32 °C condensing temperature

Capacity

Capacity in kW, range N -40 °C to 10 °C. Opening superheat sh= 6 K

R452A

Valve type	Orifice no.	Cond. temp. [°C]	Evaporating [°C]					
			-40	-30	-20	-10	0	10
			Capacity [kW]					
T2 / TE2	0X	25	0.57	0.63	0.68	0.70	0.68	0.60
T2 / TE2	00		0.75	0.96	1.15	1.29	1.32	1.22
T2 / TE2	01		1.05	1.45	1.91	2.35	2.60	2.53
T2 / TE2	02		1.17	1.66	2.29	2.98	3.53	3.64
T2 / TE2	03		1.94	2.78	3.85	5.04	5.97	6.11
T2 / TE2	04		2.79	4.01	5.66	7.60	9.27	9.80
T2 / TE2	05		3.66	5.28	7.45	10.0	12.2	12.7
T2 / TE2	06		4.33	6.27	8.89	12.0	14.5	15.0

Valve type	Orifice no.	Cond. temp. [°C]	Evaporating [°C]					
			-40	-30	-20	-10	0	10
			Capacity [kW]					
T2 / TE2	0X	35	0.54	0.62	0.68	0.71	0.73	0.69
T2 / TE2	00		0.70	0.93	1.14	1.33	1.44	1.41
T2 / TE2	01		0.99	1.40	1.89	2.42	2.83	2.95
T2 / TE2	02		1.12	1.61	2.27	3.08	3.86	4.26
T2 / TE2	03		1.86	2.70	3.84	5.24	6.56	7.18
T2 / TE2	04		2.72	3.94	5.67	7.92	10.2	11.6
T2 / TE2	05		3.56	5.17	7.46	10.4	13.4	15.0
T2 / TE2	06		4.19	6.12	8.87	12.5	16.1	17.8

Valve type	Orifice no.	Cond. temp. [°C]	Evaporating [°C]					
			-40	-30	-20	-10	0	10
			Capacity [kW]					
T2 / TE2	0X	45	0.49	0.57	0.64	0.69	0.73	0.73
T2 / TE2	00		0.64	0.85	1.07	1.28	1.44	1.49
T2 / TE2	01		0.91	1.29	1.78	2.34	2.85	3.11
T2 / TE2	02		1.03	1.49	2.14	2.99	3.90	4.51
T2 / TE2	03		1.72	2.52	3.64	5.11	6.68	7.65
T2 / TE2	04		2.56	3.70	5.39	7.73	10.4	12.4
T2 / TE2	05		3.35	4.86	7.09	10.2	13.8	16.2
T2 / TE2	06		3.91	5.72	8.40	12.2	16.5	19.2

Valve type	Orifice no.	Cond. temp. [°C]	Evaporating [°C]					
			-40	-30	-20	-10	0	10
			Capacity [kW]					
T2 / TE2	0X	55	0.42	0.51	0.58	0.63	0.67	0.69
T2 / TE2	00		0.56	0.75	0.95	1.15	1.32	1.42
T2 / TE2	01		0.79	1.14	1.58	2.11	2.63	2.97
T2 / TE2	02		0.91	1.32	1.91	2.71	3.62	4.31
T2 / TE2	03		1.53	2.24	3.25	4.65	6.24	7.35
T2 / TE2	04		2.33	3.33	4.82	7.00	9.70	11.9
T2 / TE2	05		3.04	4.36	6.35	9.26	12.9	15.7
T2 / TE2	06		3.53	5.11	7.50	11.0	15.5	18.7

Subcooling correction factor 'fsub'

Subcooling [K]	2	4	10	15	20	25	30	35	40	45	50
Correction factor	0.97	1.00	1.09	1.16	1.23	1.30	1.38	1.45	1.52	1.59	1.66

Distributor correction factor 'fp'*)

Pressure drop [bar]		Evaporating temp. [°C]											
		-40	-35	-30	-25	-20	-15	-10	-5	0	5	10	15
"Pressure drop [bar]"	0	1	1	1	1	1	1	1	1	1	1	1	1
	1	0.96	0.96	0.96	0.96	0.96	0.96	0.96	0.95	0.95	0.94	0.94	0.92
	1.5	0.95	0.95	0.94	0.94	0.94	0.94	0.93	0.93	0.92	0.91	0.90	0.88
	2	0.93	0.93	0.93	0.92	0.92	0.92	0.91	0.90	0.90	0.88	0.87	0.84

*) calculated at 32 °C condensing temperature

Capacity

Capacity in kW, range N, -40°C to 10°C, opening superheat sh= 6 K

R513A

Valve type	Orifice no.	Cond. temp. [°C]	Evaporating [°C]					
			-40	-30	-20	-10	0	10
			Capacity [kW]					
T2 / TE2	0X	25	0.39	0.46	0.51	0.54	0.53	0.47
T2 / TE2	00		0.42	0.55	0.70	0.83	0.91	0.86
T2 / TE2	01		0.55	0.76	1.0	1.3	1.5	1.6
T2 / TE2	02		0.62	0.85	1.1	1.5	1.8	2.0
T2 / TE2	03		1.0	1.4	1.9	2.5	3.1	3.3
T2 / TE2	04		1.5	2.1	2.8	3.6	4.5	5.0
T2 / TE2	05		1.9	2.6	3.5	4.6	5.7	6.4
T2 / TE2	06		2.4	3.2	4.4	5.7	7.1	7.9

Valve type	Orifice no.	Cond. temp. [°C]	Evaporating [°C]					
			-40	-30	-20	-10	0	10
			Capacity [kW]					
T2 / TE2	0X	35	0.39	0.46	0.52	0.57	0.59	0.58
T2 / TE2	00		0.41	0.56	0.72	0.88	1.0	1.1
T2 / TE2	01		0.55	0.77	1.0	1.4	1.7	1.9
T2 / TE2	02		0.61	0.86	1.2	1.6	2.0	2.4
T2 / TE2	03		1.0	1.4	2.0	2.6	3.4	4.1
T2 / TE2	04		1.5	2.1	2.9	3.9	5.0	6.2
T2 / TE2	05		2.0	2.7	3.7	4.9	6.4	7.8
T2 / TE2	06		2.4	3.3	4.5	6.1	7.9	9.8

Valve type	Orifice no.	Cond. temp. [°C]	Evaporating [°C]					
			-40	-30	-20	-10	0	10
			Capacity [kW]					
T2 / TE2	0X	45	0.37	0.45	0.51	0.57	0.61	0.62
T2 / TE2	00		0.40	0.54	0.71	0.88	1.0	1.2
T2 / TE2	01		0.54	0.75	1.0	1.4	1.7	2.1
T2 / TE2	02		0.60	0.84	1.2	1.6	2.1	2.6
T2 / TE2	03		1.0	1.4	2.0	2.7	3.5	4.5
T2 / TE2	04		1.5	2.1	2.9	3.9	5.2	6.7
T2 / TE2	05		2.0	2.7	3.7	5.0	6.7	8.5
T2 / TE2	06		2.4	3.3	4.6	6.2	8.3	10.7

Valve type	Orifice no.	Cond. temp. [°C]	Evaporating [°C]					
			-40	-30	-20	-10	0	10
			Capacity [kW]					
T2 / TE2	0X	55	0.35	0.42	0.49	0.55	0.59	0.63
T2 / TE2	00		0.38	0.52	0.68	0.85	1.0	1.2
T2 / TE2	01		0.51	0.72	0.99	1.3	1.7	2.1
T2 / TE2	02		0.57	0.81	1.1	1.6	2.1	2.7
T2 / TE2	03		0.98	1.4	1.9	2.6	3.5	4.6
T2 / TE2	04		1.5	2.1	2.9	3.9	5.2	6.8
T2 / TE2	05		1.9	2.7	3.7	5.0	6.6	8.7
T2 / TE2	06		2.3	3.2	4.5	6.1	8.2	10.8

Subcooling correction factor 'fsub'

Subcooling [K]	2	4	10	15	20	25	30	35	40	45	50
Correction factor	0.98	1.00	1.07	1.13	1.18	1.24	1.31	1.37	1.43	1.49	1.55

Distributor correction factor 'fp' *)

Pressure drop [bar]		Evaporating temp. [°C]											
		-40	-35	-30	-25	-20	-15	-10	-5	0	5	10	15
"Pressure drop [bar]"	0	1.00	1.00	1.00	1.00	1.00	1.00	1.00	1.00	1.00	1.00	1.00	1.00
	1	0.94	0.93	0.93	0.93	0.93	0.92	0.92	0.91	0.90	0.89	0.87	0.84
	1.5	0.90	0.90	0.90	0.89	0.89	0.88	0.88	0.86	0.85	0.83	0.80	0.75
	2	0.87	0.86	0.86	0.85	0.85	0.84	0.83	0.81	0.79	0.77	0.72	0.64

*) calculated at 32 °C condensing temperature

Dimensions and weights

T2 and TE2

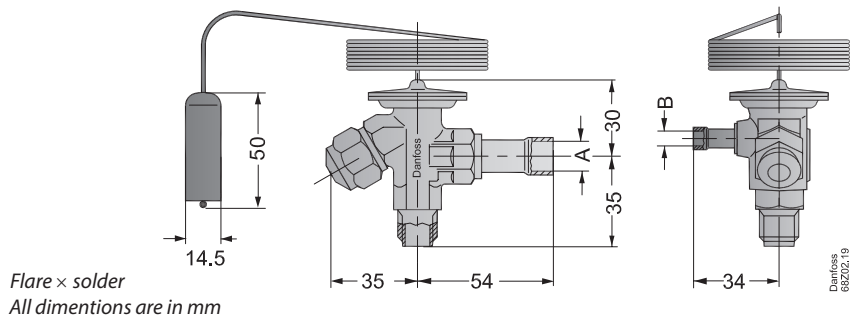
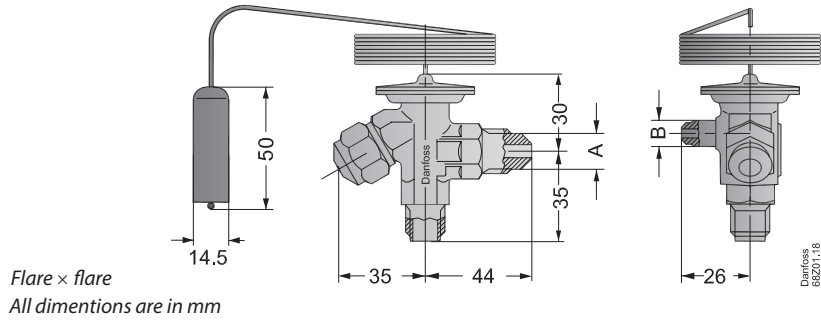

	Outlet	Equalization	Weight
	A	B	[kg / lb]
Flare x flare	1/2" flare	1/4" flare	0.3 / 0.7
Flare x solder	1/2" solder 12 mm solder	1/4" solder 6 mm solder	0.3 / 0.7

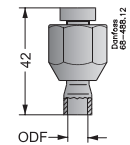

Solder adaptor

Solder ODF		Weight
[in.]	[mm]	[kg / lb]
1/4	6	0.05 / 0.11
3/8	10	0.05 / 0.11

Danfoss can accept no responsibility for possible errors in catalogues, brochures and other printed material. Danfoss reserves the right to alter its products without notice. This also applies to products already on order provided that such alterations can be made without subsequential changes being necessary in specifications already agreed. All trademarks in this material are property of the respective companies. Danfoss and the Danfoss logotype are trademarks of Danfoss A/S. All rights reserved.