



Compressor
Voltage Code : TZ

TAG4568Z

High Temp. Commercial (HP)

400V 3~ 50Hz / 440V 3~ 60 Hz

R452A / R404A / R448A / R449A

AGB4568ZTZ

Conditions	Frequency	Nominal Cooling Capacity		Sound Power ISO3745 / ISO 3743-1
		Watts	BTU/h	
EN12900 / R452A	50 Hz / 60 Hz	14480 / 17479	49377 / 59605	81 dBA
EN12900 / R404A	50 Hz / 60 Hz	14444 / 17438	49253 / 59463	81 dBA
EN12900 / R448A	50 Hz / 60 Hz	14496 / 17494	49430 / 59655	81 dBA
EN12900 / R449A	50 Hz / 60 Hz	14496 / 17494	49430 / 59655	81 dBA

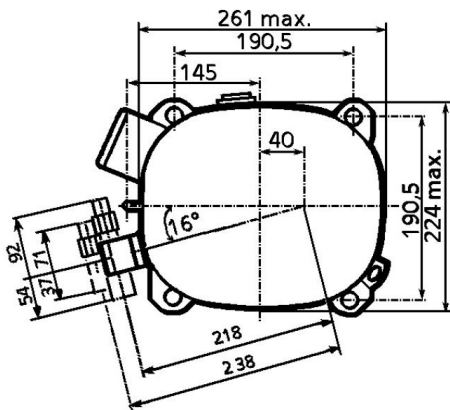
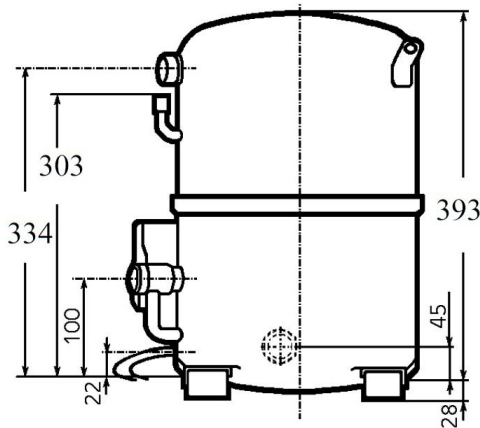

Displacement (cc)	124.4
Net Weight (Kg)	47.2
Oil Quantity (cc)	1760.0
Oil Type	Polyolester
Expansion Device	Capillary_Tube/Expansion_Valve
Cooling	Fan
Main Winding (Ohm)	2.6
Current	
RLA (A)	10.3 10.8
MCC (A)	17.8 17.5
LRA (A)	56 58
Electrical Equipment	TRI
Overload	Interne
Refrigerating connection for OD	
Suction Tube	28.6 (1"1/8)
Discharge Tube	15.9 (5/8")
Process Tube	6.35 (1/4")

* EN12900 : T°Cond. 50.0°C / T°Evap. 5.0°C / T°Return gas temp.. 20.0°C
T°Subcooling. 0.0K

Certificates :



Note : Tecumseh reserves the right to change information contained in this document without notification.



Tecumseh

TAG4568Z	Tension TZ : 400V 3~ 50Hz / 440V 3~ 60 Hz
-----------------	--

Les performances sont données dans les **conditions EN12900** :
 Condition Dew
 The performance data are in **EN12900 conditions** :
 Dew Condition

Gaz aspirés : 20.0 °C
 Sous refroidissement : 0.0 K
 Return gas : 20.0 °C
 Subcooling : 0.0 K

© 2019 Tecumseh Products Company
All rights reserved

50 Hz R452A

N°2150

4 T condensation	5 T évaporation	(°C)	-25	-20	-15	-10	-5	0	5	10	15
30	1 P frigorifique	(Watt)	5091	6791	8801	11169	13941	17166	20890	25160	30025
	2 P absorbée	(W)	2594	2983	3351	3717	4101	4523	5002	5557	6209
	3 I absorbée	(A)	4.75	5.28	5.79	6.31	6.82	7.32	7.83	8.33	8.83
40	1 P frigorifique	(Watt)		5322	7131	9229	11664	14483	17734	21463	25718
	2 P absorbée	(W)		3024	3496	3940	4376	4822	5299	5827	6425
	3 I absorbée	(A)		5.28	5.93	6.58	7.23	7.87	8.51	9.15	9.78
50	1 P frigorifique	(Watt)			5431	7243	9324	11720	14480	17651	21279
	2 P absorbée	(W)			3531	4109	4652	5179	5712	6268	6868
	3 I absorbée	(A)			5.97	6.75	7.53	8.31	9.09	9.87	10.6
60	1 P frigorifique	(Watt)				5225	6934	8891	11144	13739	16724
	2 P absorbée	(W)				4156	4863	5529	6172	6813	7472
	3 I absorbée	(A)				6.80	7.73	8.65	9.57	10.5	11.4

60 Hz R452A

N°2150

4 T condensation	5 T évaporation	(°C)	-25	-20	-15	-10	-5	0	5	10	15
30	1 P frigorifique	(Watt)	6239	8331	10887	13834	17102	20618	24310	28105	31933
	2 P absorbée	(W)	3221	3795	4341	4874	5407	5954	6530	7147	7819
	3 I absorbée	(A)	5.40	6.13	6.88	7.63	8.39	9.16	9.94	10.7	11.5
40	1 P frigorifique	(Watt)		6653	8842	11448	14401	17627	21056	24614	28230
	2 P absorbée	(W)		3820	4494	5131	5745	6351	6960	7589	8250
	3 I absorbée	(A)		6.13	7.01	7.89	8.78	9.68	10.6	11.5	12.5
50	1 P frigorifique	(Watt)			6839	9013	11560	14406	17479	20709	24022
	2 P absorbée	(W)			4470	5265	6014	6731	7429	8122	8825
	3 I absorbée	(A)			7.01	8.03	9.06	10.1	11.1	12.2	13.3
60	1 P frigorifique	(Watt)				6411	8460	10834	13462	16272	19191
	2 P absorbée	(W)				5155	6092	6974	7813	8625	9423
	3 I absorbée	(A)				8.05	9.22	10.4	11.6	12.8	14.0

1 = cooling capacity 2 = power input 3 = current 4 = condensing temperature 5 = evaporating temperature

Nota : Tecumseh se réserve le droit de modifier les informations contenues dans ce document sans préavis.

Note : Tecumseh reserves the right to change information contained in this document without notification.



Tecumseh

TAG4568Z	Tension TZ : 400V 3~ 50Hz / 440V 3~ 60 Hz
-----------------	--

Les performances sont données dans les conditions EN12900 :	Gaz aspirés :	20.0 °C
Condition Dew	Sous refroidissement :	0.0 K
The performance data are in EN12900 conditions :	Return gas :	20.0 °C
Dew Condition	Subcooling :	0.0 K

50 Hz R404A											
 N°227JU-T											
4 T condensation	5 T évaporation	(°C)	-25	-20	-15	-10	-5	0	5	10	15
30	1 P frigorifique	(Watt)	5428	7159	9193	11574	14348	17558	21248	25463	30248
	2 P absorbée	(W)	2748	3147	3523	3895	4284	4707	5186	5739	6385
	3 I absorbée	(A)	5.04	5.57	6.09	6.61	7.12	7.62	8.12	8.60	9.08
40	1 P frigorifique	(Watt)	4015	5606	7425	9519	11931	14705	17887	21520	25649
	2 P absorbée	(W)	2674	3205	3686	4135	4573	5018	5491	6011	6597
	3 I absorbée	(A)	4.93	5.60	6.26	6.91	7.55	8.19	8.82	9.44	10.0
50	1 P frigorifique	(Watt)		4049	5639	7429	9463	11787	14444	17478	20935
	2 P absorbée	(W)		3101	3742	4325	4868	5392	5916	6459	7041
	3 I absorbée	(A)		5.53	6.32	7.11	7.88	8.65	9.41	10.2	10.9
60	1 P frigorifique	(Watt)			3857	5327	6969	8825	10941	13362	16131
	2 P absorbée	(W)			3627	4399	5105	5764	6395	7018	7653
	3 I absorbée	(A)			6.28	7.20	8.11	9.02	9.91	10.8	11.7

60 Hz R404A											
 N°227JU-T											
4 T condensation	5 T évaporation	(°C)	-25	-20	-15	-10	-5	0	5	10	15
30	1 P frigorifique	(Watt)	6649	8787	11375	14337	17599	21088	24729	28446	32167
	2 P absorbée	(W)	3412	4004	4564	5107	5647	6197	6770	7380	8040
	3 I absorbée	(A)	5.72	6.47	7.23	7.99	8.76	9.53	10.3	11.1	11.9
40	1 P frigorifique	(Watt)	5277	7007	9208	11807	14728	17897	21239	24682	28149
	2 P absorbée	(W)	3304	4048	4737	5385	6004	6609	7213	7829	8472
	3 I absorbée	(A)	5.61	6.50	7.39	8.28	9.18	10.1	11.0	11.9	12.8
50	1 P frigorifique	(Watt)		5381	7103	9244	11730	14486	17438	20511	23632
	2 P absorbée	(W)		3866	4737	5541	6294	7007	7694	8370	9048
	3 I absorbée	(A)		6.41	7.43	8.45	9.48	10.5	11.5	12.6	13.6
60	1 P frigorifique	(Watt)			4952	6542	8499	10749	13216	15828	18508
	2 P absorbée	(W)			4443	5458	6396	7271	8096	8884	9650
	3 I absorbée	(A)			7.36	8.52	9.68	10.8	12.0	13.2	14.3

1 = cooling capacity 2 = power input 3 = current 4 = condensing temperature 5 = evaporating temperature

Nota : Tecumseh se réserve le droit de modifier les informations contenues dans ce document sans préavis.
Note : Tecumseh reserves the right to change information contained in this document without notification.

© 2019 Tecumseh Products Company
All rights reserved



Tecumseh

TAG4568Z	Tension TZ : 400V 3~ 50Hz / 440V 3~ 60 Hz
-----------------	--

Les performances sont données dans les conditions EN12900 :	Gaz aspirés :	20.0 °C
Condition Dew	Sous refroidissement :	0.0 K
The performance data are in EN12900 conditions :	Return gas :	20.0 °C
Dew Condition	Subcooling :	0.0 K

50 Hz R448A (*)											
											N°2873
4 T condensation	5 T évaporation	(°C)	-25	-20	-15	-10	-5	0	5	10	15
30	1 P frigorifique	(Watt)	4486	6135	8097	10423	13166	16380	20116	24428	29368
	2 P absorbée	(W)	2419	2776	3122	3471	3841	4247	4706	5233	5846
	3 I absorbée	(A)	4.43	4.91	5.40	5.89	6.39	6.88	7.37	7.84	8.31
40	1 P frigorifique	(Watt)		4832	6609	8694	11139	13996	17319	21159	25570
	2 P absorbée	(W)		2840	3280	3700	4115	4542	4997	5495	6054
	3 I absorbée	(A)		4.96	5.57	6.18	6.80	7.41	8.03	8.63	9.22
50	1 P frigorifique	(Watt)			5110	6950	9093	11590	14496	17861	21739
	2 P absorbée	(W)			3335	3889	4414	4925	5440	5973	6542
	3 I absorbée	(A)			5.64	6.39	7.15	7.90	8.66	9.40	10.1
60	1 P frigorifique	(Watt)				5235	7072	9207	11691	14578	17920
	2 P absorbée	(W)				3947	4646	5306	5945	6577	7220
	3 I absorbée	(A)				6.47	7.38	8.30	9.21	10.1	11.0

60 Hz R448A (*)											
											N°2873
4 T condensation	5 T évaporation	(°C)	-25	-20	-15	-10	-5	0	5	10	15
30	1 P frigorifique	(Watt)	5503	7517	10009	12910	16154	19676	23408	27284	31237
	2 P absorbée	(W)	3004	3531	4043	4551	5064	5592	6144	6730	7361
	3 I absorbée	(A)	5.03	5.71	6.41	7.12	7.86	8.60	9.35	10.1	10.8
40	1 P frigorifique	(Watt)		6038	8191	10787	13758	17039	20562	24262	28071
	2 P absorbée	(W)		3587	4216	4818	5404	5983	6564	7158	7774
	3 I absorbée	(A)		5.76	6.57	7.41	8.26	9.12	9.99	10.9	11.7
50	1 P frigorifique	(Watt)			6429	8650	11279	14249	17494	20948	24543
	2 P absorbée	(W)			4222	4983	5706	6400	7075	7740	8406
	3 I absorbée	(A)			6.63	7.60	8.60	9.60	10.6	11.6	12.7
60	1 P frigorifique	(Watt)				6418	8634	11224	14122	17260	20572
	2 P absorbée	(W)				4896	5820	6693	7526	8327	9106
	3 I absorbée	(A)				7.65	8.80	9.98	11.2	12.3	13.5

1 = cooling capacity 2 = power input 3 = current 4 = condensing temperature 5 = evaporating temperature

(*) Veuillez vous référer strictement aux Recommandations d'Utilisation et Bulletins Marketing Tecumseh du fait de la température de reflux élevée pour les applications LBP.
 (*) Due to very high discharge temperature especially on LBP conditions, please strictly refer to Tecumseh Guidelines & Marketing Bulletin when using this refrigerant.

Nota : Tecumseh se réserve le droit de modifier les informations contenues dans ce document sans préavis.

Note : Tecumseh reserves the right to change information contained in this document without notification.

© 2019 Tecumseh Products Company
All rights reserved



Tecumseh

TAG4568Z	Tension TZ : 400V 3~ 50Hz / 440V 3~ 60 Hz
-----------------	--

Les performances sont données dans les conditions EN12900 :	Gaz aspirés :	20.0 °C
Condition Dew	Sous refroidissement :	0.0 K
The performance data are in EN12900 conditions :	Return gas :	20.0 °C
Dew Condition	Subcooling :	0.0 K

50 Hz R449A (*)											
											N°2266
4 T condensation	5 T évaporation	(°C)	-25	-20	-15	-10	-5	0	5	10	15
30	1 P frigorifique	(Watt)	4486	6135	8097	10423	13166	16380	20116	24428	29368
	2 P absorbée	(W)	2419	2776	3122	3471	3841	4247	4706	5233	5846
	3 I absorbée	(A)	4.43	4.91	5.40	5.89	6.39	6.88	7.37	7.84	8.31
40	1 P frigorifique	(Watt)		4832	6609	8694	11139	13996	17319	21159	25570
	2 P absorbée	(W)		2840	3280	3700	4115	4542	4997	5495	6054
	3 I absorbée	(A)		4.96	5.57	6.18	6.80	7.41	8.03	8.63	9.22
50	1 P frigorifique	(Watt)			5110	6950	9093	11590	14496	17861	21739
	2 P absorbée	(W)			3335	3889	4414	4925	5440	5973	6542
	3 I absorbée	(A)			5.64	6.39	7.15	7.90	8.66	9.40	10.1
60	1 P frigorifique	(Watt)				5235	7072	9207	11691	14578	17920
	2 P absorbée	(W)				3947	4646	5306	5945	6577	7220
	3 I absorbée	(A)				6.47	7.38	8.30	9.21	10.1	11.0

60 Hz R449A (*)											
											N°2266
4 T condensation	5 T évaporation	(°C)	-25	-20	-15	-10	-5	0	5	10	15
30	1 P frigorifique	(Watt)	5503	7517	10009	12910	16154	19676	23408	27284	31237
	2 P absorbée	(W)	3004	3531	4043	4551	5064	5592	6144	6730	7361
	3 I absorbée	(A)	5.03	5.71	6.41	7.12	7.86	8.60	9.35	10.1	10.8
40	1 P frigorifique	(Watt)		6038	8191	10787	13758	17039	20562	24262	28071
	2 P absorbée	(W)		3587	4216	4818	5404	5983	6564	7158	7774
	3 I absorbée	(A)		5.76	6.57	7.41	8.26	9.12	9.99	10.9	11.7
50	1 P frigorifique	(Watt)			6429	8650	11279	14249	17494	20948	24543
	2 P absorbée	(W)			4222	4983	5706	6400	7075	7740	8406
	3 I absorbée	(A)			6.63	7.60	8.60	9.60	10.6	11.6	12.7
60	1 P frigorifique	(Watt)				6418	8634	11224	14122	17260	20572
	2 P absorbée	(W)				4896	5820	6693	7526	8327	9106
	3 I absorbée	(A)				7.65	8.80	9.98	11.2	12.3	13.5

1 = cooling capacity 2 = power input 3 = current 4 = condensing temperature 5 = evaporating temperature

(*) Veuillez vous référer strictement aux Recommandations d'Utilisation et Bulletins Marketing Tecumseh du fait de la température de reflux élevée pour les applications LBP.
 (*) Due to very high discharge temperature especially on LBP conditions, please strictly refer to Tecumseh Guidelines & Marketing Bulletin when using this refrigerant.

Nota : Tecumseh se réserve le droit de modifier les informations contenues dans ce document sans préavis.
Note : Tecumseh reserves the right to change information contained in this document without notification.

© 2019 Tecumseh Products Company
All rights reserved