

Condensing unit
Voltage Code : TZ

TAGT4581ZHR-TZ

High Temp. Commercial (HP)
400V 3~ 50Hz / 440V 3~ 60 Hz
R452A / R404A / R448A / R449A
TAGT4581ZHR-TZ

Conditions	Frequency	Nominal Cooling Capacity		Sound Power ISO3745 / ISO 3743-1
		Watts	BTU/h	
EN13215 / R452A	50 Hz / 60 Hz	17118 / 19023	58372 / 64868	86 dBA
EN13215 / R404A	50 Hz / 60 Hz	17661 / 19263	60225 / 65688	86 dBA
EN13215 / R448A	50 Hz / 60 Hz	16787 / 18803	57243 / 64119	86 dBA
EN13215 / R449A	50 Hz / 60 Hz	16798 / 18815	57281 / 64160	86 dBA

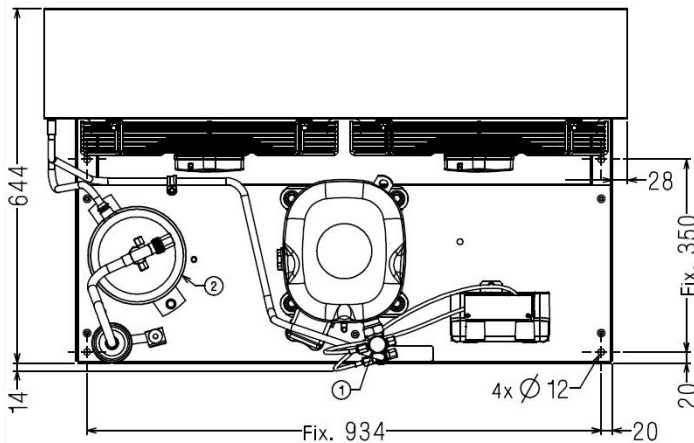
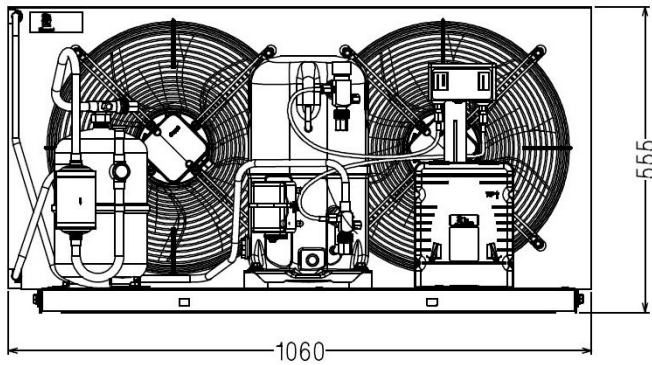

* EN13215 : T°Ambient 32.0°C / T°Evap. 5.0°C / T°Return gas temp.. 20.0°C
 T°Subcooling. 3.0K

Net Weight (Kg)	107.0
Expansion device	Expansion_Valve
Air Flow (m³/h)	6000 / 6800
Compo Data Sheet	227MU-T
Elec Comp Type	TRI
Current (Amp)	
Load Rated Amp	15.3 16.9
Max Cont Current	23.1 24.4
Lock Rotor Amp	89 91
Fan	
Speed (rpm)	1360 / 1520
Power (W)	280.0
Diameter (mm)	420
Protection	Overload
IP Level	IP54
Condenser	B420P/45000
Liquid Receiver	
Capacity (L)	6.0
Maximum Pressure (Bars)	32.0
Suction Line	
Suction Type	Vanne Orientable
For Tubing Out Diam	28.6 (1"1/8)
Suction Connection Type	Brased
Liquid Line	
Liquid Line Type	Vanne Orientable
For Tubing Out Diam	15.9 (5/8")
Liquid Connecton Type	Brased
Connection Type	VR
Fan Guard	maille < à 8mm

Note : Tecumseh reserves the right to change information contained in this document without notification.



Tecumseh

TAGT4581ZHR-TZ	Tension TZ : 400V 3~ 50Hz / 440V 3~ 60 Hz
-----------------------	--

Les performances sont données dans les conditions EN13215 :	Gaz aspirés :	20.0 °C
Condition Dew	Sous refroidissement :	3.0 K
The performance data are in EN13215 conditions :	Return gas :	20.0 °C
Dew Condition	Subcooling :	3.0 K

50 Hz R452A											
											N°6724
5 T ambience	6 T évaporation	(°C)	-25	-20	-15	-10	-5	0	5	10	15
25	1 P frigorifique	(Watt)	6028	7763	9691	11795	14047	16416	18873	21408	24046
	2 P absorbée	(W)	3816	4357	4906	5481	6098	6769	7505	8315	9208
	3 I absorbée	(A)	9.26	9.80	10.4	11.1	11.9	12.9	13.9	15.1	16.4
	4 Tc	(°C)	27.9	29.3	31.2	33.4	35.9	38.7	41.5	44.5	47.5
32	1 P frigorifique	(Watt)		6837	8669	10636	12715	14883	17118	19420	21838
	2 P absorbée	(W)		4390	4994	5613	6264	6964	7724	8555	9466
	3 I absorbée	(A)		9.85	10.5	11.3	12.2	13.1	14.2	15.4	16.7
	4 Tc	(°C)		35.4	37.0	39.0	41.3	43.8	46.5	49.4	52.2
43	1 P frigorifique	(Watt)			6972	8734	10559	12436	14364	16376	18600
	2 P absorbée	(W)			5031	5745	6471	7231	8040	8912	9857
	3 I absorbée	(A)			10.6	11.5	12.4	13.5	14.6	15.9	17.3
	4 Tc	(°C)			46.4	47.9	49.9	52.0	54.4	56.9	59.5

60 Hz R452A											
											N°6724
5 T ambience	6 T évaporation	(°C)	-25	-20	-15	-10	-5	0	5	10	15
25	1 P frigorifique	(Watt)		8695	10882	13228	15714	18318	21024	23836	26811
	2 P absorbée	(W)		5498	6224	6993	7824	8737	9746	10866	12107
	3 I absorbée	(A)		10.7	11.6	12.5	13.6	14.8	16.1	17.6	19.2
	4 Tc	(°C)		32.4	34.2	36.3	38.7	41.4	44.2	47.1	50.0
32	1 P frigorifique	(Watt)		7613	9704	11901	14195	16571	19023	21574	24322
	2 P absorbée	(W)		5521	6321	7147	8023	8972	10011	11157	12421
	3 I absorbée	(A)		10.7	11.7	12.7	13.8	15.1	16.5	17.9	19.6
	4 Tc	(°C)		38.7	40.2	42.1	44.3	46.8	49.4	52.1	54.9
43	1 P frigorifique	(Watt)			7710	9681	11689	13741	15860	18134	
	2 P absorbée	(W)			6314	7271	8251	9281	10385	11583	
	3 I absorbée	(A)			11.8	12.9	14.1	15.5	16.9	18.4	
	4 Tc	(°C)			49.9	51.4	53.2	55.3	57.6	60.0	

1 = cooling capacity 2 = power input 3 = current 4 = condensing temperature 5 = ambient temperature 6 = evaporating temperature

Nota : Tecumseh se réserve le droit de modifier les informations contenues dans ce document sans préavis.

Note : Tecumseh reserves the right to change information contained in this document without notification.

© 2019 Tecumseh Products Company
All rights reserved



Tecumseh

TAGT4581ZHR-TZ	Tension TZ : 400V 3~ 50Hz / 440V 3~ 60 Hz
-----------------------	--

Les performances sont données dans les conditions EN13215 :	Gaz aspirés :	20.0 °C
Condition Dew	Sous refroidissement :	3.0 K
The performance data are in EN13215 conditions :	Return gas :	20.0 °C
Dew Condition	Subcooling :	3.0 K

50 Hz R404A											
											N°6723
5 T ambience	6 T évaporation	(°C)	-25	-20	-15	-10	-5	0	5	10	15
25	1 P frigorifique	(Watt)	6870	8595	10520	12619	14859	17195	19580	21973	24350
	2 P absorbée	(W)	3719	4270	4831	5413	6031	6696	7419	8209	9078
	3 I absorbée	(A)	9.67	10.2	10.8	11.5	12.3	13.3	14.3	15.4	16.7
	4 Tc	(°C)	30.1	31.9	34.0	36.2	38.6	41.3	44.1	47.0	50.1
32	1 P frigorifique	(Watt)	6002	7651	9453	11386	13422	15526	17661	19799	21940
	2 P absorbée	(W)	3709	4322	4935	5560	6213	6906	7650	8457	9337
	3 I absorbée	(A)	9.68	10.3	11.0	11.7	12.6	13.5	14.6	15.7	17.0
	4 Tc	(°C)	36.1	37.8	39.7	41.8	44.1	46.5	49.1	51.9	54.7
43	1 P frigorifique	(Watt)			7719	9393	11115	12865	14623	16393	18235
	2 P absorbée	(W)			5007	5720	6445	7197	7988	8831	9737
	3 I absorbée	(A)			11.1	12.0	12.9	13.9	15.0	16.2	17.5
	4 Tc	(°C)			48.6	50.5	52.6	54.8	57.1	59.5	62.1

60 Hz R404A											
											N°6723
5 T ambience	6 T évaporation	(°C)	-25	-20	-15	-10	-5	0	5	10	15
25	1 P frigorifique	(Watt)	7328	9335	11512	13842	16299	18849	21454	24081	26729
	2 P absorbée	(W)	5045	5768	6509	7289	8124	9031	10025	11121	12333
	3 I absorbée	(A)	10.3	11.1	12.0	13.0	14.1	15.3	16.6	18.0	19.5
	4 Tc	(°C)	33.3	35.0	36.9	39.0	41.4	43.9	46.6	49.5	52.4
32	1 P frigorifique	(Watt)		8236	10284	12432	14662	16948	19263	21597	23982
	2 P absorbée	(W)		5820	6629	7464	8343	9284	10305	11421	12647
	3 I absorbée	(A)		11.2	12.1	13.2	14.3	15.5	16.9	18.3	19.9
	4 Tc	(°C)		41.0	42.8	44.8	47.0	49.3	51.9	54.5	57.3
43	1 P frigorifique	(Watt)			8250	10107	11981	13862	15751	17684	
	2 P absorbée	(W)			6677	7630	8607	9626	10709	11872	
	3 I absorbée	(A)			12.3	13.4	14.7	16.0	17.4	18.9	
	4 Tc	(°C)			52.0	53.8	55.8	57.9	60.1	62.4	

1 = cooling capacity 2 = power input 3 = current 4 = condensing temperature 5 = ambient temperature 6 = evaporating temperature

Nota : Tecumseh se réserve le droit de modifier les informations contenues dans ce document sans préavis.

Note : Tecumseh reserves the right to change information contained in this document without notification.

© 2019 Tecumseh Products Company
All rights reserved



Tecumseh

TAGT4581ZHR-TZ	Tension TZ : 400V 3~ 50Hz / 440V 3~ 60 Hz
-----------------------	--

Les performances sont données dans les conditions EN13215 :	Gaz aspirés :	20.0 °C
Condition Dew	Sous refroidissement :	3.0 K
The performance data are in EN13215 conditions :	Return gas :	20.0 °C
Dew Condition	Subcooling :	3.0 K

50 Hz R448A (*)											
											N°7050
5 T ambience	6 T évaporation	(°C)	-25	-20	-15	-10	-5	0	5	10	15
25	1 P frigorifique	(Watt)	5084	6747	8637	10755	13094	15637	18353	21207	24155
	2 P absorbée	(W)	3600	4118	4648	5202	5795	6438	7146	7934	8819
	3 I absorbée	(A)	8.83	9.35	9.95	10.6	11.4	12.3	13.3	14.5	15.8
	4 Tc	(°C)	28.3	30.0	31.8	33.8	36.0	38.5	41.2	44.2	47.5
32	1 P frigorifique	(Watt)		5953	7742	9726	11905	14265	16787	19441	22197
	2 P absorbée	(W)		4151	4736	5339	5974	6654	7395	8210	9118
	3 I absorbée	(A)		9.42	10.1	10.8	11.7	12.6	13.7	14.9	16.2
	4 Tc	(°C)		35.9	37.6	39.5	41.6	44.0	46.5	49.3	52.3
43	1 P frigorifique	(Watt)			6304	8088	10025	12111	14338	16694	
	2 P absorbée	(W)			4775	5478	6200	6956	7761	8632	
	3 I absorbée	(A)			10.2	11.1	12.0	13.0	14.2	15.4	
	4 Tc	(°C)			46.9	48.6	50.5	52.5	54.8	57.3	

60 Hz R448A (*)											
											N°7050
5 T ambience	6 T évaporation	(°C)	-25	-20	-15	-10	-5	0	5	10	15
25	1 P frigorifique	(Watt)		7563	9722	12103	14710	17536	20561	23760	27104
	2 P absorbée	(W)		5213	5913	6655	7455	8334	9311	10406	11640
	3 I absorbée	(A)		10.2	11.1	12.0	13.1	14.2	15.5	17.0	18.6
	4 Tc	(°C)		33.1	34.8	36.7	38.9	41.3	43.9	46.8	49.9
32	1 P frigorifique	(Watt)		6633	8692	10935	13369	15995	18803	21776	24899
	2 P absorbée	(W)		5235	6010	6817	7673	8600	9618	10748	12012
	3 I absorbée	(A)		10.3	11.2	12.2	13.3	14.6	15.9	17.4	19.0
	4 Tc	(°C)		39.3	40.9	42.7	44.7	46.9	49.4	52.0	55.0
43	1 P frigorifique	(Watt)				9051	11218	13539			
	2 P absorbée	(W)				6940	7919	8951			
	3 I absorbée	(A)				12.5	13.7	15.0			
	4 Tc	(°C)				52.0	53.8	55.8			

1 = cooling capacity 2 = power input 3 = current 4 = condensing temperature 5 = ambient temperature 6 = evaporating temperature

(*) Veuillez vous référer strictement aux Recommandations d'Utilisation et Bulletins Marketing Tecumseh du fait de la température de reflux élevée pour les applications LBP.
 (*) Due to very high discharge temperature especially on LBP conditions, please strictly refer to Tecumseh Guidelines & Marketing Bulletin when using this refrigerant.

Nota : Tecumseh se réserve le droit de modifier les informations contenues dans ce document sans préavis.
Note : Tecumseh reserves the right to change information contained in this document without notification.

© 2019 Tecumseh Products Company
All rights reserved



Tecumseh

TAGT4581ZHR-TZ	Tension TZ : 400V 3~ 50Hz / 440V 3~ 60 Hz
-----------------------	--

Les performances sont données dans les conditions EN13215 :	Gaz aspirés :	20.0 °C
Condition Dew	Sous refroidissement :	3.0 K
The performance data are in EN13215 conditions :	Return gas :	20.0 °C
Dew Condition	Subcooling :	3.0 K

50 Hz R449A (*)											
											N°6822
5 T ambience	6 T évaporation	(°C)	-25	-20	-15	-10	-5	0	5	10	15
25	1 P frigorifique	(Watt)	5086	6750	8641	10761	13102	15647	18366	21223	24175
	2 P absorbée	(W)	3600	4118	4648	5202	5795	6438	7146	7934	8819
	3 I absorbée	(A)	8.83	9.35	9.95	10.6	11.4	12.3	13.3	14.5	15.8
	4 Tc	(°C)	28.3	30.0	31.8	33.8	36.1	38.5	41.2	44.2	47.5
32	1 P frigorifique	(Watt)		5956	7746	9732	11912	14274	16798	19454	22212
	2 P absorbée	(W)		4151	4736	5339	5974	6654	7394	8210	9118
	3 I absorbée	(A)		9.42	10.1	10.8	11.7	12.6	13.7	14.9	16.2
	4 Tc	(°C)		35.9	37.6	39.5	41.6	43.9	46.5	49.3	52.3
43	1 P frigorifique	(Watt)			6307	8092	10030	12117	14346	16703	
	2 P absorbée	(W)			4775	5478	6200	6956	7761	8632	
	3 I absorbée	(A)			10.2	11.1	12.0	13.0	14.2	15.4	
	4 Tc	(°C)			46.8	48.5	50.4	52.5	54.7	57.2	

60 Hz R449A (*)											
											N°6822
5 T ambience	6 T évaporation	(°C)	-25	-20	-15	-10	-5	0	5	10	15
25	1 P frigorifique	(Watt)		7567	9728	12111	14719	17547	20576	23778	27125
	2 P absorbée	(W)		5213	5913	6655	7455	8334	9311	10406	11640
	3 I absorbée	(A)		10.2	11.1	12.0	13.1	14.2	15.5	17.0	18.6
	4 Tc	(°C)		33.1	34.8	36.8	38.9	41.3	43.9	46.8	49.9
32	1 P frigorifique	(Watt)		6637	8697	10941	13377	16005	18815	21790	24915
	2 P absorbée	(W)		5235	6010	6817	7673	8600	9618	10748	12012
	3 I absorbée	(A)		10.3	11.2	12.2	13.3	14.6	15.9	17.4	19.0
	4 Tc	(°C)		39.3	40.9	42.7	44.7	46.9	49.3	52.0	54.9
43	1 P frigorifique	(Watt)				9055	11224	13546			
	2 P absorbée	(W)				6940	7919	8951			
	3 I absorbée	(A)				12.5	13.7	15.0			
	4 Tc	(°C)				52.0	53.8	55.7			

1 = cooling capacity 2 = power input 3 = current 4 = condensing temperature 5 = ambient temperature 6 = evaporating temperature

(*) Veuillez vous référer strictement aux Recommandations d'Utilisation et Bulletins Marketing Tecumseh du fait de la température de reflux élevée pour les applications LBP.

(*) Due to very high discharge temperature especially on LBP conditions, please strictly refer to Tecumseh Guidelines & Marketing Bulletin when using this refrigerant.

Nota : Tecumseh se réserve le droit de modifier les informations contenues dans ce document sans préavis.

Note : Tecumseh reserves the right to change information contained in this document without notification.

© 2019 Tecumseh Products Company
All rights reserved