



Compressor
Voltage Code : TZ

TFH4522Z

High Temp. Commercial (HP)

400V 3~ 50Hz / 440V 3~ 60 Hz

R452A / R404A / R448A / R449A

AHC4522TZ

Conditions	Frequency	Nominal Cooling Capacity		Sound Power ISO3745 / ISO 3743-1
		Watts	BTU/h	
EN12900 / R452A	50 Hz / 60 Hz	4640 / 5467	15823 / 18644	72 dBA
EN12900 / R404A	50 Hz / 60 Hz	4629 / 5454	15784 / 18599	72 dBA
EN12900 / R448A	50 Hz / 60 Hz	4645 / 5473	15838 / 18662	72 dBA
EN12900 / R449A	50 Hz / 60 Hz	4645 / 5473	15838 / 18662	72 dBA

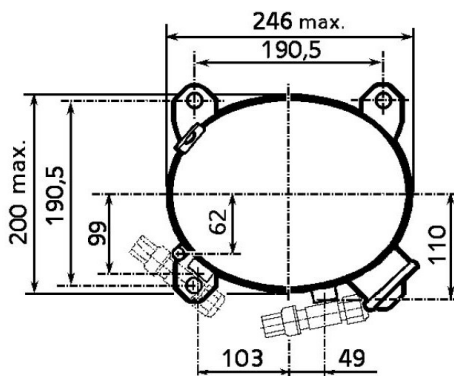
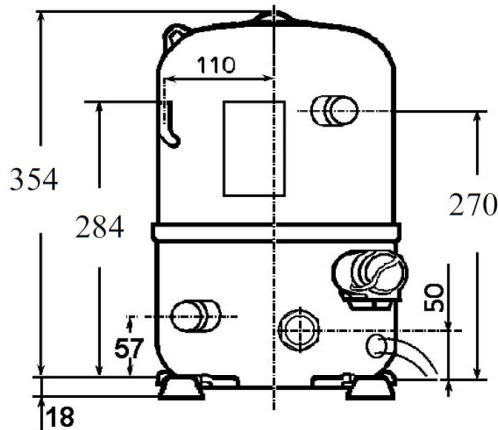

* EN12900 : T°Cond. 50.0°C / T°Evap. 5.0°C / T°Return gas temp.. 20.0°C
T°Subcooling. 0.0K

Certificates :



Displacement (cc)	39.9
Net Weight (Kg)	30.0
Oil Quantity (cc)	1330.0
Oil Type	Polyolester
Expansion Device	Capillary_Tube/Expansion_Valve
Cooling	Fan
Main Winding (Ohm)	6.3
Current	
RLA (A)	3.9 4.1
MCC (A)	5.4 5.9
LRA (A)	24 26
Electrical Equipment	TRI
Overload	Interne
Refrigerating connection for OD	
Suction Tube	15.9 (5/8")
Discharge Tube	12.7 (1/2")
Process Tube	6.35 (1/4")

Note : Tecumseh reserves the right to change information contained in this document without notification.



Tecumseh

TFH4522Z	Tension TZ : 400V 3~ 50Hz / 440V 3~ 60 Hz
-----------------	--

Les performances sont données dans les **conditions EN12900** :
 Condition Dew
 The performance data are in **EN12900 conditions** :
 Dew Condition

Gaz aspirés : 20.0 °C
 Sous refroidissement : 0.0 K
 Return gas : 20.0 °C
 Subcooling : 0.0 K

© 2019 Tecumseh Products Company
All rights reserved

50 Hz R452A

N°2108

4 T condensation	5 T évaporation	(°C)	-25	-20	-15	-10	-5	0	5	10	15
30	1 P frigorifique	(Watt)	1458	2037	2728	3548	4513	5639	6943	8441	10149
	2 P absorbée	(W)	956	1106	1237	1353	1460	1560	1658	1759	1867
	3 I absorbée	(A)	2.60	2.76	2.91	3.05	3.17	3.28	3.37	3.45	3.52
40	1 P frigorifique	(Watt)		1554	2172	2892	3732	4706	5832	7125	8602
	2 P absorbée	(W)		1107	1286	1445	1587	1718	1840	1960	2080
	3 I absorbée	(A)		2.76	2.97	3.17	3.36	3.53	3.68	3.83	3.95
50	1 P frigorifique	(Watt)			1576	2188	2891	3703	4640	5718	6954
	2 P absorbée	(W)			1262	1476	1668	1842	2002	2153	2299
	3 I absorbée	(A)			2.94	3.20	3.44	3.68	3.90	4.10	4.29
60	1 P frigorifique	(Watt)				1465	2023	2662	3401	4254	5238
	2 P absorbée	(W)				1421	1675	1906	2116	2312	2496
	3 I absorbée	(A)				3.12	3.43	3.73	4.01	4.28	4.54

60 Hz R452A

N°2108

4 T condensation	5 T évaporation	(°C)	-25	-20	-15	-10	-5	0	5	10	15
30	1 P frigorifique	(Watt)	1675	2424	3291	4294	5448	6769	8273	9977	11896
	2 P absorbée	(W)	1079	1304	1493	1657	1809	1959	2121	2305	2523
	3 I absorbée	(A)	2.36	2.58	2.78	2.97	3.15	3.31	3.47	3.61	3.74
40	1 P frigorifique	(Watt)		1768	2556	3445	4451	5590	6878	8332	9966
	2 P absorbée	(W)		1245	1508	1731	1926	2106	2281	2463	2665
	3 I absorbée	(A)		2.50	2.77	3.03	3.27	3.51	3.73	3.94	4.13
50	1 P frigorifique	(Watt)			1791	2570	3431	4392	5467	6674	8027
	2 P absorbée	(W)			1427	1731	1992	2222	2433	2636	2844
	3 I absorbée	(A)			2.68	3.01	3.32	3.63	3.92	4.20	4.46
60	1 P frigorifique	(Watt)				1675	2395	3181	4047	5010	6085
	2 P absorbée	(W)				1630	1978	2281	2550	2795	3031
	3 I absorbée	(A)				2.91	3.30	3.67	4.03	4.38	4.72

1 = cooling capacity 2 = power input 3 = current 4 = condensing temperature 5 = evaporating temperature

Nota : Tecumseh se réserve le droit de modifier les informations contenues dans ce document sans préavis.

Note : Tecumseh reserves the right to change information contained in this document without notification.



Tecumseh

TFH4522Z	Tension TZ : 400V 3~ 50Hz / 440V 3~ 60 Hz
-----------------	--

Les performances sont données dans les conditions EN12900 :	Gaz aspirés :	20.0 °C
Condition Dew	Sous refroidissement :	0.0 K
The performance data are in EN12900 conditions :	Return gas :	20.0 °C
Dew Condition	Subcooling :	0.0 K

50 Hz R404A											
 N°226CU-T											
4 T condensation	5 T évaporation	(°C)	-25	-20	-15	-10	-5	0	5	10	15
30	1 P frigorifique	(Watt)	1555	2147	2849	3677	4644	5767	7062	8542	10224
	2 P absorbée	(W)	1013	1167	1301	1418	1524	1623	1719	1816	1919
	3 I absorbée	(A)	2.75	2.91	3.06	3.19	3.31	3.41	3.50	3.57	3.62
40	1 P frigorifique	(Watt)	1093	1636	2261	2983	3817	4778	5882	7144	8579
	2 P absorbée	(W)	964	1173	1356	1516	1659	1787	1907	2022	2136
	3 I absorbée	(A)	2.70	2.93	3.14	3.33	3.51	3.67	3.82	3.95	4.06
50	1 P frigorifique	(Watt)		1097	1636	2243	2934	3724	4629	5663	6842
	2 P absorbée	(W)		1093	1338	1554	1746	1917	2074	2219	2357
	3 I absorbée	(A)		2.84	3.11	3.36	3.60	3.83	4.03	4.23	4.40
60	1 P frigorifique	(Watt)			1010	1494	2033	2643	3339	4136	5051
	2 P absorbée	(W)			1220	1505	1759	1987	2193	2381	2557
	3 I absorbée	(A)			2.98	3.30	3.60	3.89	4.15	4.41	4.64

60 Hz R404A											
 N°226CU-T											
4 T condensation	5 T évaporation	(°C)	-25	-20	-15	-10	-5	0	5	10	15
30	1 P frigorifique	(Watt)	1786	2555	3438	4450	5606	6923	8415	10097	11985
	2 P absorbée	(W)	1143	1376	1569	1737	1889	2039	2199	2380	2594
	3 I absorbée	(A)	2.50	2.72	2.93	3.11	3.29	3.45	3.59	3.73	3.84
40	1 P frigorifique	(Watt)	1142	1863	2661	3553	4552	5676	6938	8354	9939
	2 P absorbée	(W)	995	1320	1590	1817	2013	2192	2363	2541	2737
	3 I absorbée	(A)	2.36	2.65	2.92	3.18	3.42	3.65	3.86	4.06	4.24
50	1 P frigorifique	(Watt)		1140	1859	2635	3482	4417	5454	6609	7897
	2 P absorbée	(W)		1145	1513	1822	2085	2314	2520	2717	2916
	3 I absorbée	(A)		2.50	2.84	3.17	3.48	3.77	4.06	4.32	4.58
60	1 P frigorifique	(Watt)			1043	1707	2407	3158	3974	4873	5867
	2 P absorbée	(W)			1312	1726	2077	2378	2642	2879	3104
	3 I absorbée	(A)			2.69	3.08	3.46	3.83	4.18	4.51	4.83

1 = cooling capacity 2 = power input 3 = current 4 = condensing temperature 5 = evaporating temperature

Nota : Tecumseh se réserve le droit de modifier les informations contenues dans ce document sans préavis.
Note : Tecumseh reserves the right to change information contained in this document without notification.

© 2019 Tecumseh Products Company
All rights reserved



Tecumseh

TFH4522Z	Tension TZ : 400V 3~ 50Hz / 440V 3~ 60 Hz
-----------------	--

Les performances sont données dans les conditions EN12900 :	Gaz aspirés :	20.0 °C
Condition Dew	Sous refroidissement :	0.0 K
The performance data are in EN12900 conditions :	Return gas :	20.0 °C
Dew Condition	Subcooling :	0.0 K

© 2019 Tecumseh Products Company
All rights reserved

50 Hz R448A (*)

N°2834

4 T condensation	5 T évaporation	(°C)	-25	-20	-15	-10	-5	0	5	10	15
30	1 P frigorifique	(Watt)	1285	1840	2509	3310	4261	5381	6686	8196	9927
	2 P absorbée	(W)	891	1029	1153	1264	1367	1465	1560	1656	1756
	3 I absorbée	(A)	2.42	2.57	2.71	2.85	2.97	3.08	3.18	3.25	3.31
40	1 P frigorifique	(Watt)		1411	2013	2725	3564	4548	5696	7025	8552
	2 P absorbée	(W)		1039	1206	1357	1493	1618	1736	1849	1960
	3 I absorbée	(A)		2.59	2.79	2.98	3.16	3.32	3.47	3.61	3.73
50	1 P frigorifique	(Watt)			1484	2099	2820	3662	4645	5786	7103
	2 P absorbée	(W)			1192	1397	1582	1751	1907	2052	2190
	3 I absorbée	(A)			2.77	3.02	3.27	3.49	3.71	3.91	4.09
60	1 P frigorifique	(Watt)				1468	2063	2756	3568	4514	5615
	2 P absorbée	(W)				1351	1601	1829	2038	2232	2413
	3 I absorbée	(A)				2.97	3.28	3.57	3.86	4.13	4.38

60 Hz R448A (*)

N°2834

4 T condensation	5 T évaporation	(°C)	-25	-20	-15	-10	-5	0	5	10	15
30	1 P frigorifique	(Watt)	1476	2190	3027	4006	5145	6459	7968	9687	11635
	2 P absorbée	(W)	1005	1213	1391	1548	1694	1840	1995	2170	2375
	3 I absorbée	(A)	2.20	2.40	2.59	2.78	2.95	3.11	3.26	3.40	3.51
40	1 P frigorifique	(Watt)		1604	2369	3246	4252	5403	6718	8214	9908
	2 P absorbée	(W)		1169	1415	1626	1812	1984	2151	2324	2511
	3 I absorbée	(A)		2.34	2.60	2.84	3.08	3.30	3.52	3.71	3.89
50	1 P frigorifique	(Watt)			1684	2466	3347	4343	5473	6752	8200
	2 P absorbée	(W)			1348	1639	1890	2113	2317	2512	2709
	3 I absorbée	(A)			2.53	2.85	3.15	3.45	3.73	4.00	4.25
60	1 P frigorifique	(Watt)				1680	2443	3292	4244	5315	6524
	2 P absorbée	(W)				1548	1890	2189	2455	2699	2929
	3 I absorbée	(A)				2.77	3.15	3.52	3.88	4.23	4.56

1 = cooling capacity 2 = power input 3 = current 4 = condensing temperature 5 = evaporating temperature

(*) Veuillez vous référer strictement aux Recommandations d'Utilisation et Bulletins Marketing Tecumseh du fait de la température de reflux élevée pour les applications LBP.

(*) Due to very high discharge temperature especially on LBP conditions, please strictly refer to Tecumseh Guidelines & Marketing Bulletin when using this refrigerant.

Nota : Tecumseh se réserve le droit de modifier les informations contenues dans ce document sans préavis.

Note : Tecumseh reserves the right to change information contained in this document without notification.



Tecumseh

TFH4522Z	Tension TZ : 400V 3~ 50Hz / 440V 3~ 60 Hz
-----------------	--

Les performances sont données dans les conditions EN12900 :	Gaz aspirés :	20.0 °C
Condition Dew	Sous refroidissement :	0.0 K
The performance data are in EN12900 conditions :	Return gas :	20.0 °C
Dew Condition	Subcooling :	0.0 K

© 2019 Tecumseh Products Company
All rights reserved

50 Hz R449A (*)

N°2223

4 T condensation	5 T évaporation	(°C)	-25	-20	-15	-10	-5	0	5	10	15
30	1 P frigorifique	(Watt)	1285	1840	2509	3310	4261	5381	6686	8196	9927
	2 P absorbée	(W)	891	1029	1153	1264	1367	1465	1560	1656	1756
	3 I absorbée	(A)	2.42	2.57	2.71	2.85	2.97	3.08	3.18	3.25	3.31
40	1 P frigorifique	(Watt)		1411	2013	2725	3564	4548	5696	7025	8552
	2 P absorbée	(W)		1039	1206	1357	1493	1618	1736	1849	1960
	3 I absorbée	(A)		2.59	2.79	2.98	3.16	3.32	3.47	3.61	3.73
50	1 P frigorifique	(Watt)			1484	2099	2820	3662	4645	5786	7103
	2 P absorbée	(W)			1192	1397	1582	1751	1907	2052	2190
	3 I absorbée	(A)			2.77	3.02	3.27	3.49	3.71	3.91	4.09
60	1 P frigorifique	(Watt)				1468	2063	2756	3568	4514	5615
	2 P absorbée	(W)				1351	1601	1829	2038	2232	2413
	3 I absorbée	(A)				2.97	3.28	3.57	3.86	4.13	4.38

60 Hz R449A (*)

N°2223

4 T condensation	5 T évaporation	(°C)	-25	-20	-15	-10	-5	0	5	10	15
30	1 P frigorifique	(Watt)	1476	2190	3027	4006	5145	6459	7968	9687	11635
	2 P absorbée	(W)	1005	1213	1391	1548	1694	1840	1995	2170	2375
	3 I absorbée	(A)	2.20	2.40	2.59	2.78	2.95	3.11	3.26	3.40	3.51
40	1 P frigorifique	(Watt)		1604	2369	3246	4252	5403	6718	8214	9908
	2 P absorbée	(W)		1169	1415	1626	1812	1984	2151	2324	2511
	3 I absorbée	(A)		2.34	2.60	2.84	3.08	3.30	3.52	3.71	3.89
50	1 P frigorifique	(Watt)			1684	2466	3347	4343	5473	6752	8200
	2 P absorbée	(W)			1348	1639	1890	2113	2317	2512	2709
	3 I absorbée	(A)			2.53	2.85	3.15	3.45	3.73	4.00	4.25
60	1 P frigorifique	(Watt)				1680	2443	3292	4244	5315	6524
	2 P absorbée	(W)				1548	1890	2189	2455	2699	2929
	3 I absorbée	(A)				2.77	3.15	3.52	3.88	4.23	4.56

1 = cooling capacity 2 = power input 3 = current 4 = condensing temperature 5 = evaporating temperature

(*) Veuillez vous référer strictement aux Recommandations d'Utilisation et Bulletins Marketing Tecumseh du fait de la température de reflux élevée pour les applications LBP.

(*) Due to very high discharge temperature especially on LBP conditions, please strictly refer to Tecumseh Guidelines & Marketing Bulletin when using this refrigerant.

Nota : Tecumseh se réserve le droit de modifier les informations contenues dans ce document sans préavis.

Note : Tecumseh reserves the right to change information contained in this document without notification.