

UEMT6144Z

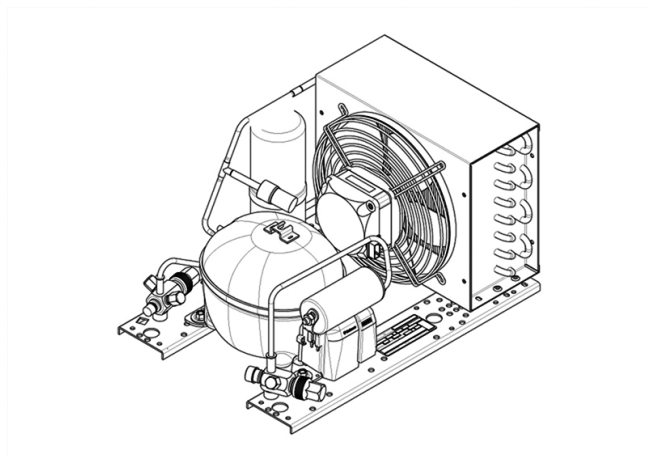

ENGINEERING CODE
594PA5312AA



REFRIGERANT
R-134a



POWER SUPPLY
220-240 V 50 Hz



APPLICATION
HBP



MOTOR TYPE
RSIR



STANDARD
EN13215_RG20



COOLING CAPACITY
291 W



EFFICIENCY
1.64 W/W

CE

ECODESIGN COMPLIANT

DATA

GENERAL DATA

Model UEMT6144Z

CONDENSING COMPONENTS

Compressor	EMT6144Z	M/HBP
Condenser	3R8T	2451204
Refrigerant	R-134a	
Expansion Device	C-V	
Fan Blade Diameter	200	
Fankit	10W 200/28/5B	1996581

MECHANICAL DATA

Air Flow	300 m ³ /h
Height	226 mm
Shaft Power	10
Weight	13 Kg
Width	290 mm
Length	430 mm

PERFORMANCE

TESTED CONDITIONS

Tested Refrigerant	R-134a
Tested Application	HBP
Tested Standard	EN13215_RG20

RATED POINTS

Ambient Temperature °C	Evaporating Temperature °C	Cooling Capacity W	Efficiency W/W	Consumo de Potencia W
32	-10	291	1.64	178

Test Condition: Subcooling 3 K, Return Gas 20 °C.

PERFORMANCE CURVE

Ambient Temperature 25°C

Evaporating Temperature °C	Cooling Capacity W	Efficiency W/W	Consumo de Potencia W
-15	258	1.63	159
-5	388	2.07	188
0	466	2.28	204
5	553	2.49	222
10	649	2.69	241

Test Condition: Subcooling 3 K, Return Gas 20 °C.

PERFORMANCE CURVE

Ambient Temperature 32°C

Evaporating Temperature °C	Cooling Capacity W	Efficiency W/W	Consumo de Potencia W
-15	233	1.42	164
-5	355	1.84	193
0	426	2.03	210
5	503	2.20	229
10	589	2.36	249

Test Condition: Subcooling 3 K, Return Gas 20 °C.

PERFORMANCE CURVE

Ambient Temperature 43°C

Evaporating Temperature °C	Cooling Capacity W	Efficiency W/W	Consumo de Potencia W
-15	193	1.11	173
-5	320	1.57	204
0	388	1.75	222
5	461	1.90	242

Test Condition: Subcooling 3 K, Return Gas 20 °C.

ENVELOPE

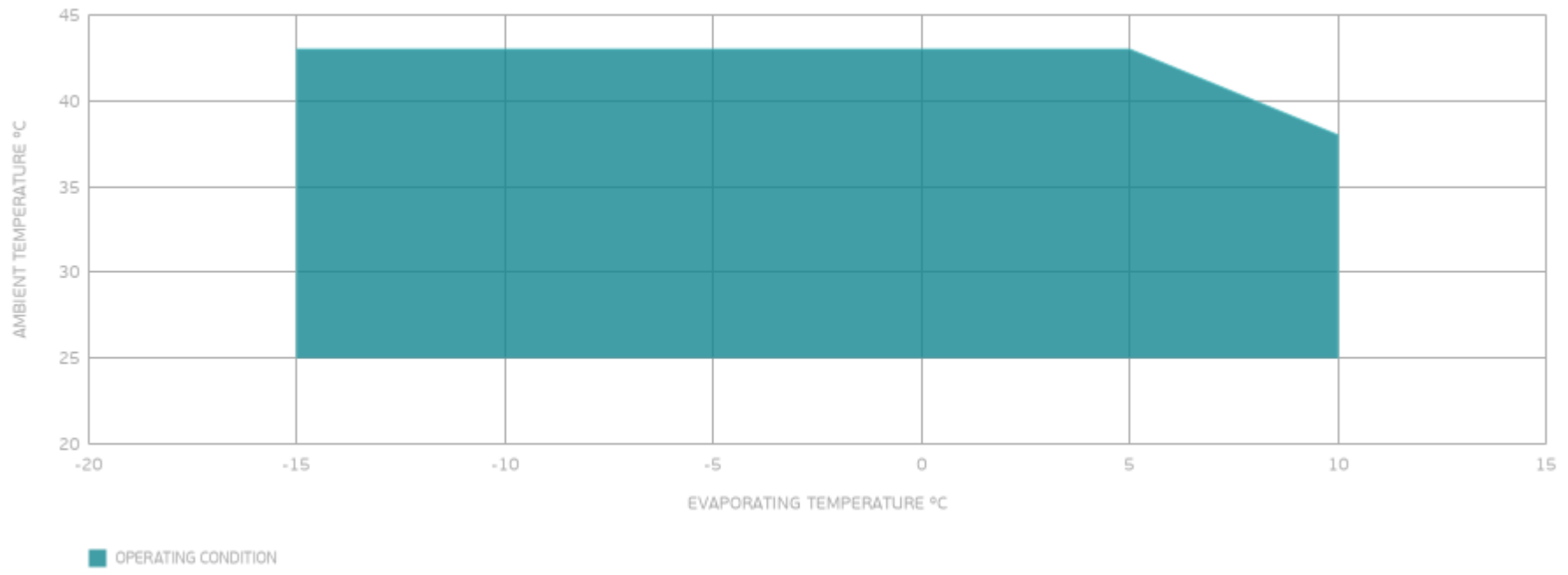

EXTERNAL DIMENSIONS

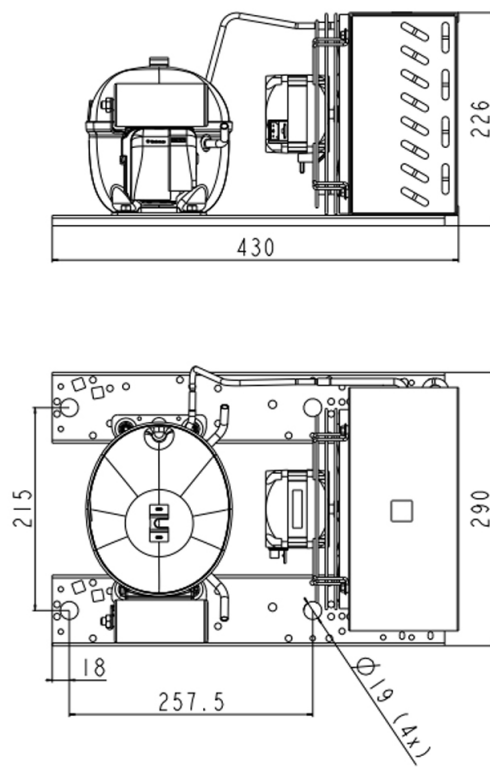

WIRING DIAGRAM

