

UNEK6181GK

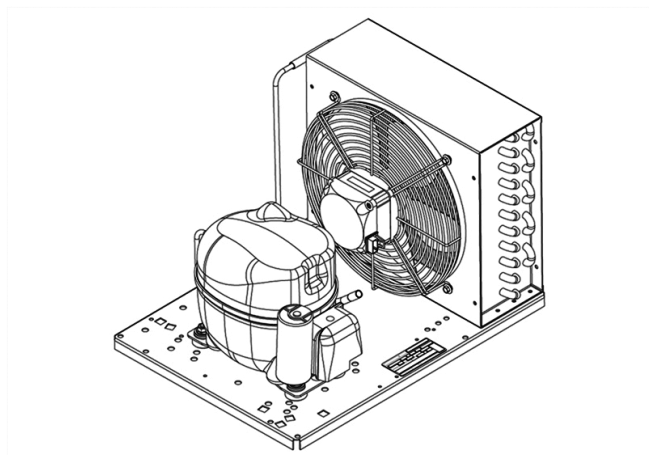

CE

ENGINEERING CODE
557MA5312AA

POWER SUPPLY
220-240 V 50 Hz

MOTOR TYPE
CSIR

REFRIGERANT
R-404A

APPLICATION
HBP

STANDARD
EN13215_RG20

COOLING CAPACITY
653 W

EFFICIENCY
1.51 W/W

DATA

GENERAL DATA

Model	UNEK6181GK
-------	------------

CONDENSING COMPONENTS

Compressor	NEK6181GK	M/HBP
Condenser	3R11T	2451206
Refrigerant	R-404A	
Expansion Device	C-V	
Fan Blade Diameter	254	
Fankit	16W 254/28/5B	1996579

MECHANICAL DATA

Air Flow	595 m ³ /h
Height	296 mm
Shaft Power	16
Weight	20 Kg
Width	340 mm
Length	465 mm

PERFORMANCE

TESTED CONDITIONS

Tested Refrigerant	R-404A
Tested Application	HBP
Tested Standard	EN13215_RG20

RATED POINTS

Ambient Temperature °C	Evaporating Temperature °C	Cooling Capacity W	Efficiency W/W	Consumo de Potencia W
32	-10	653	1.51	432

Test Condition: Subcooling 3 K, Return Gas 20 °C.

PERFORMANCE CURVE

Ambient Temperature 25°C

Evaporating Temperature °C	Cooling Capacity W	Efficiency W/W	Consumo de Potencia W
-20	475	1.33	357
-15	582	1.52	384
-5	831	1.87	444
0	975	2.05	475
5	1134	2.24	507
10	1310	2.43	539

Test Condition: Subcooling 3 K, Return Gas 20 °C.

PERFORMANCE CURVE

Ambient Temperature 32°C

Evaporating Temperature °C	Cooling Capacity W	Efficiency W/W	Consumo de Potencia W
-20	446	1.21	368
-15	544	1.37	399
-5	773	1.65	467
0	906	1.80	504
5	1053	1.95	540
10	1215	2.11	577

Test Condition: Subcooling 3 K, Return Gas 20 °C.

PERFORMANCE CURVE

Ambient Temperature 43°C

Evaporating Temperature °C	Cooling Capacity W	Efficiency W/W	Consumo de Potencia W
-20	386	1.01	381
-15	475	1.12	423
-5	681	1.33	513
0	799	1.42	561
5	931	1.53	609

Test Condition: Subcooling 3 K, Return Gas 20 °C.

ENVELOPE

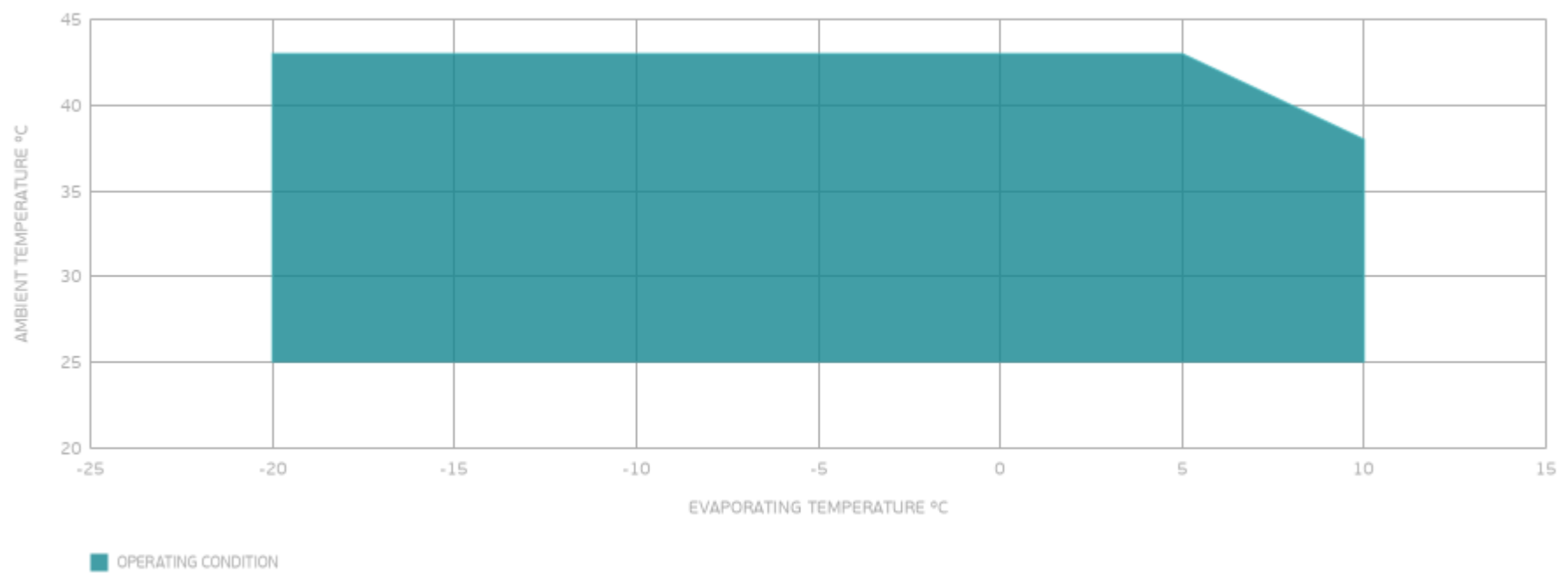

EXTERNAL DIMENSIONS

