

UNT2192GK

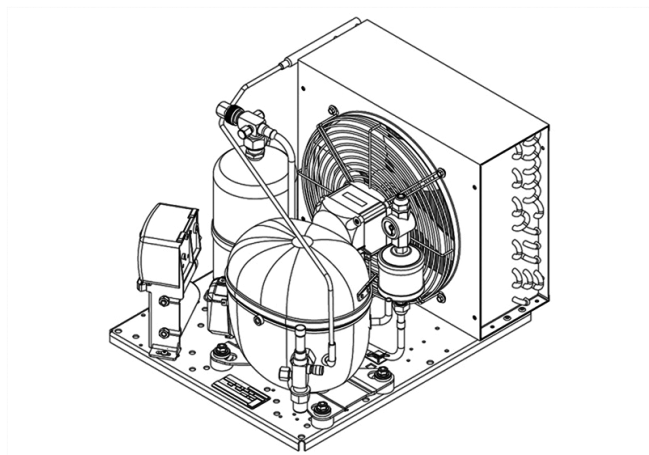

ENGINEERING CODE
503EA5212AA



POWER SUPPLY
220-240 V 50 Hz



MOTOR TYPE
CSIR



REFRIGERANT
R-404A



APPLICATION
LBP



STANDARD
EN13215_RG20



COOLING CAPACITY
595 W



EFFICIENCY
0.94 W/W

CE

ECODESIGN COMPLIANT

DATA

GENERAL DATA

Model UNT2192GK

ACCESSORIES

Discharge valve FLARE 3/8" 2110056

Suction valve FLARE 3/8" 2110024

CONDENSING COMPONENTS

Compressor NT2192GK LBP

Condenser 3R12T 2451218

Refrigerant R-404A

Expansion Device C-V

Fan Blade Diameter 275

Fankit 34W 275/31/5B 1996588

MECHANICAL DATA

Air Flow	800 m ³ /h
Height	323 mm
Receiver	2.3 L
Shaft Power	34
Weight	34 Kg
Width	395 mm
Length	494 mm

PERFORMANCE

TESTED CONDITIONS

Tested Refrigerant	R-404A
Tested Application	LBP
Tested Standard	EN13215_RG20

RATED POINTS

Ambient Temperature °C	Evaporating Temperature °C	Cooling Capacity W	Efficiency W/W	Consumo de Potencia W
32	-35	595	0.94	632

Test Condition: Subcooling 3 K, Return Gas 20 °C.

PERFORMANCE CURVE

Ambient Temperature 25°C

Evaporating Temperature °C	Cooling Capacity W	Efficiency W/W	Consumo de Potencia W
-40	486	0.93	524
-30	855	1.22	704
-25	1091	1.37	798
-20	1361	1.52	896
-15	1664	1.67	996
-10	2001	1.82	1098

Test Condition: Subcooling 3 K, Return Gas 20 °C.

PERFORMANCE CURVE

Ambient Temperature 32°C

Evaporating Temperature °C	Cooling Capacity W	Efficiency W/W	Consumo de Potencia W
-40	443	0.81	544
-30	777	1.07	725
-25	991	1.21	821
-20	1236	1.34	922
-15	1513	1.47	1026
-10	1820	1.61	1134

Test Condition: Subcooling 3 K, Return Gas 20 °C.

PERFORMANCE CURVE

Ambient Temperature 43°C

Evaporating Temperature °C	Cooling Capacity W	Efficiency W/W	Consumo de Potencia W
-40	417	0.76	546
-30	754	1.01	750
-25	963	1.12	861
-20	1199	1.23	977
-15	1461	1.33	1099

Test Condition: Subcooling 3 K, Return Gas 20 °C.

ENVELOPE

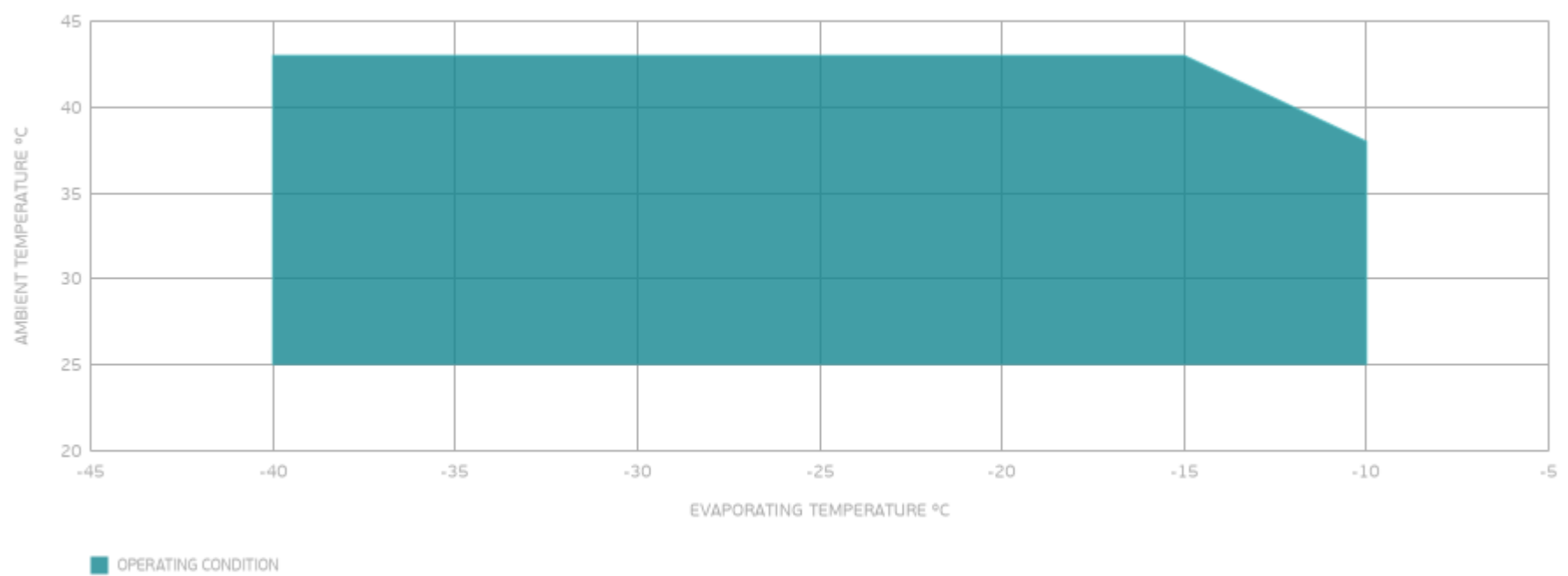

EXTERNAL DIMENSIONS

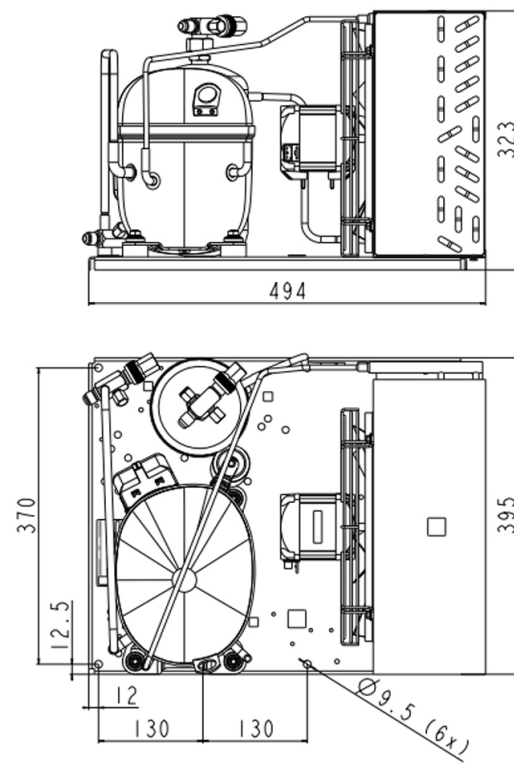

WIRING DIAGRAM

