

UNT2212GK

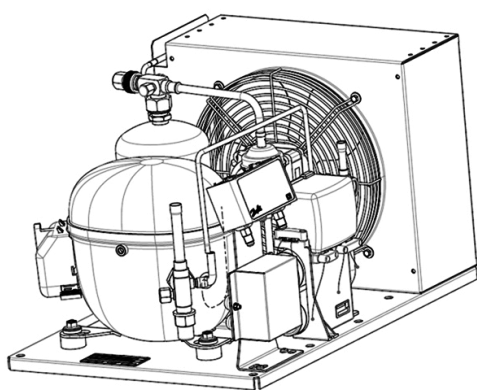

ENGINEERING CODE
505DA5204AA



POWER SUPPLY
220-240 V 50 Hz



MOTOR TYPE
CSR



REFRIGERANT
R-404A



APPLICATION
LBP



STANDARD
EN13215_RG20

CE

ECODESIGN COMPLIANT



COOLING CAPACITY
821 W



EFFICIENCY
1.07 W/W

DATA

GENERAL DATA

Model UNT2212GK

ACCESSORIES

Discharge valve FLARE 3/8" 2110056

Suction valve FLARE 1/2" 2110057

CONDENSING COMPONENTS

Compressor NT2212GK LBP

Condenser 3R12T 2451140

Refrigerant R-404A

Expansion Device C-V

Fan Blade Diameter 275

Fankit 34W 275/31/5B 1996583

MECHANICAL DATA

Air Flow	800 m ³ /h
Height	324 mm
Receiver	2.3 L
Shaft Power	34
Weight	34 Kg
Width	395 mm
Length	494 mm

PERFORMANCE

TESTED CONDITIONS

Tested Refrigerant	R-404A
Tested Application	LBP
Tested Standard	EN13215_RG20

RATED POINTS

Ambient Temperature °C	Evaporating Temperature °C	Cooling Capacity W	Efficiency W/W	Consumo de Potencia W
32	-35	821	1.07	767

Test Condition: Subcooling 3 K, Return Gas 20 °C.

PERFORMANCE CURVE

Ambient Temperature 25°C

Evaporating Temperature °C	Cooling Capacity W	Efficiency W/W	Consumo de Potencia W
-40	728	1.15	636
-30	1128	1.33	851
-25	1386	1.44	965
-20	1672	1.53	1090
-15	1978	1.61	1229
-10	2297	1.66	1388

Test Condition: Subcooling 3 K, Return Gas 20 °C.

PERFORMANCE CURVE

Ambient Temperature 32°C

Evaporating Temperature °C	Cooling Capacity W	Efficiency W/W	Consumo de Potencia W
-40	654	0.99	661
-30	1027	1.17	877
-25	1264	1.27	993
-20	1525	1.36	1122
-15	1801	1.42	1266
-10	2085	1.46	1432

Test Condition: Subcooling 3 K, Return Gas 20 °C.

PERFORMANCE CURVE

Ambient Temperature 43°C

Evaporating Temperature °C	Cooling Capacity W	Efficiency W/W	Consumo de Potencia W
-40	509	0.76	665
-30	848	0.94	900
-25	1057	1.03	1029
-20	1283	1.09	1173
-15	1516	1.14	1335

Test Condition: Subcooling 3 K, Return Gas 20 °C.

ENVELOPE

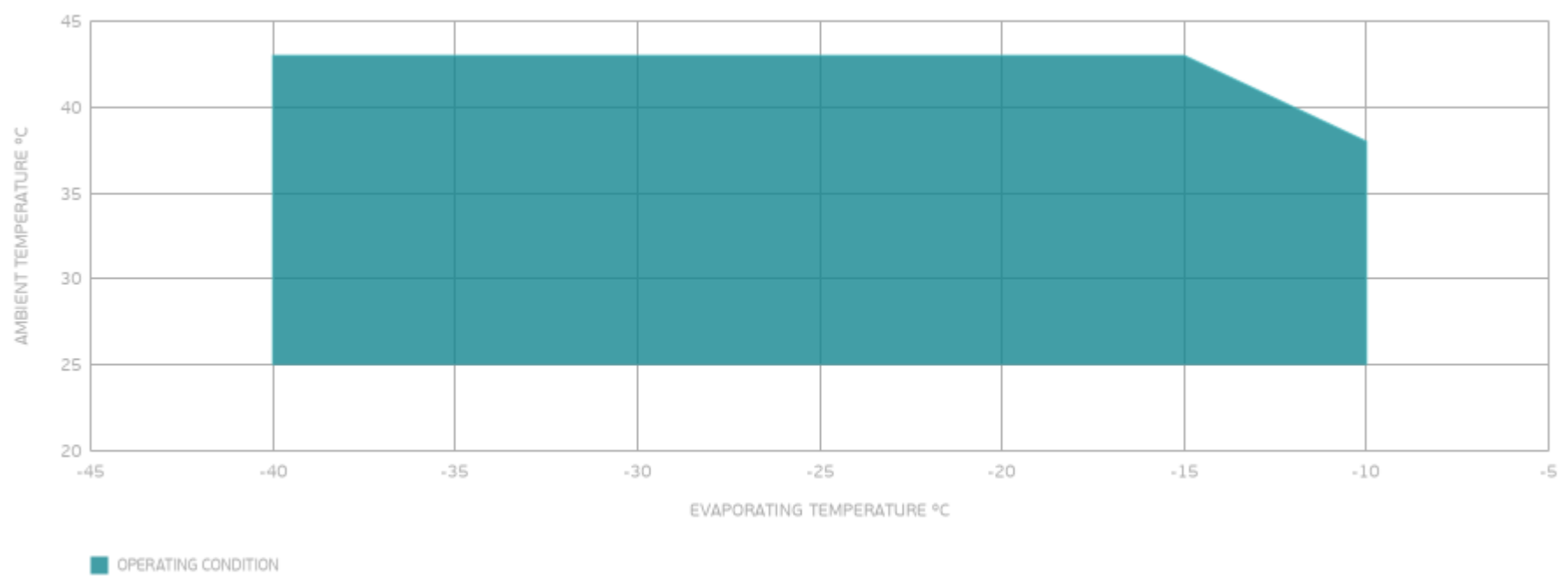

EXTERNAL DIMENSIONS

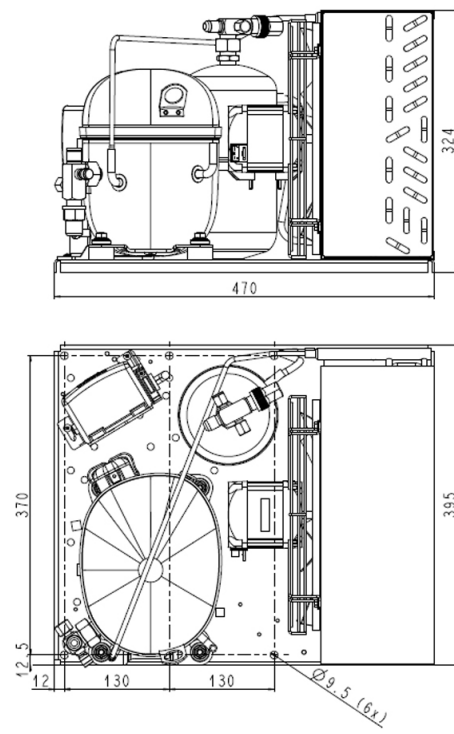

WIRING DIAGRAM

